



Reference Book Of International Building Standards

Author: Dr. Abozar Shahpari



Translator: Dr. Altin Hakan
Editor: Mohammad Savari Poor

In The Name of God

**The Omnipresent, The Omniscient,
And The Omnipotent**

Reference Book Of International Building Standards

Author:

Dr. Abozar Shahpari

Translator: Dr.

Altin Hakan

| | |
|------------------------------|---|
| ID | Shahpari, Abozar,1984 – |
| Contract title | English Reference Book Of International Building Standards |
| Author's title and name | Reference book of international building standards[Book]/ author Abozar Shahpari, translator Altin Hakan; [editor Mohammad Sawaripour]. |
| Publication specifications | Tehran: Taseer, 2023. |
| Appearance characteristics | 470 p: Illustrated. |
| ISBN | 978-622-90095-5-9 |
| Listing status | fipa |
| Note | English language. |
| Note | Bibliography: p. [439] – 470 |
| Issue | Construction industry -- Handbooks, manuals, etc Construction industry -- Standards Concrete construction-- Iran -- Handbooks, manuals, etc |
| Added ID | Hakan ,Altin , 1927 |
| Congress classification | TH151 |
| Dewey classification | 721 |
| National bibliography number | 9375421 |

title of the book

Reference Book Of International Building Standards

| | |
|----------------------|-------------------------------|
| Publisher | Taseer |
| Authors | Dr. Abozar Shahpari |
| Translator | Dr. Altin Hakan |
| production manager | Fatemeh Nadipour |
| Editor | Mohammad Sawaripour |
| Number | 1000 volumes |
| edition | First, 2023 |
| Printing and binding | Amatis |
| Print supervisor | Hamidreza Khashai Varnamkhasi |
| ISBN | 978-622-90096-5-9 |
| Price | \$293 |

| |
|---|
| <p>Contact number: 02191015922 All rights reserved to the publisher</p> |
|---|

Dedicated to:

Young engineers of my country,

Those whose day and night efforts are the promise of the prosperity of the country,

Dedicated to those who spend days and nights of their life in the way of building a safe house for their compatriot, so that everyone can have a bright days and nights,

And dedicated to all young engineers who want to implement their art in construction engineering with international principles and standards.



Table of Contents

| | |
|--|-----------|
| Chapter One | 15 |
| Concrete buildings..... | 15 |
| Design methods of reinforced concrete structures | 16 |
| working-stress method..... | 16 |
| ultimate-strength method..... | 17 |
| Design based on limit states metod | 17 |
| Concrete..... | 18 |
| Types of concrete | 20 |
| Common types of concrete used in construction..... | 21 |
| Plain concrete | 21 |
| Normal strength concrete | 21 |
| Precast concrete | 21 |
| Prestressed concrete..... | 22 |
| Ready-mixed concrete | 23 |
| reinforced concrete | 24 |
| Lightweight Concrete | 24 |
| Permeable concrete..... | 25 |
| Mehri concrete..... | 25 |
| Aerated concrete..... | 25 |
| Asphalt concrete | 26 |
| Shotcrete concrete | 26 |
| Lime concrete | 26 |
| Concrete impregnated with polymer | 26 |
| Glass concrete..... | 27 |
| Self-compacting concrete | 27 |
| High density concrete | 27 |
| Vacuum concrete | 27 |
| Volumetric concrete | 28 |
| Decorative concrete..... | 28 |
| Concrete composition..... | 31 |
| Cement..... | 32 |
| Construction Materials | 34 |
| Concrete production | 36 |
| Design composition..... | 37 |
| Asphalt concrete | 40 |
| Graphene reinforced concrete..... | 40 |

| | |
|--|-----|
| microbial..... | 41 |
| Nano concrete..... | 41 |
| Transient concrete | 41 |
| polymer..... | 41 |
| Volcanic..... | 42 |
| Light concrete waste..... | 42 |
| Sulfur concrete..... | 42 |
| Properties of concrete | 42 |
| Environmental effects of concrete..... | 44 |
| Rebars and its types | 47 |
| The concept of rebar..... | 48 |
| Steps and principles of implementation of reinforcement..... | 49 |
| Types of reinforcement patches..... | 52 |
| Foundation..... | 56 |
| Concrete building implementation steps | 65 |
| Destruction | 65 |
| Excavation | 65 |
| Implementation of lean concrete | 71 |
| Foundation shuttering..... | 84 |
| Planning for the concrete pouring process | 87 |
| Implementation of the column..... | 89 |
| Structure | 90 |
| Naming | 90 |
| Extensions | 91 |
| bases | 92 |
| Steps to execution a column..... | 92 |
| Column reinforcing | 93 |
| Circular columns | 94 |
| Spacer parts to strengthen the column..... | 95 |
| Column shuttering | 96 |
| execution of beams (puter) | 102 |
| Types of beams in structures | 104 |
| Implementation of the roof..... | 109 |
| Types | 110 |
| Elements | 110 |
| Roof Coatings..... | 113 |
| Basic technique of roof cinstruction..... | 113 |
| Stairs construction | 114 |
| Concreting beams, roof and staircase..... | 116 |
| Hardening operation | 120 |

| | |
|--|-----|
| Excavation of the building..... | 121 |
| Joinery | 122 |
| darby (squared timber) for the wall..... | 124 |
| The final flooring..... | 125 |
| Building facades..... | 127 |
| Cleaning steps..... | 128 |
| Water and sewage piping..... | 128 |
| Building plumbing..... | 128 |
| Signing a fire extinguishing and fire alarm contract with(...) | 134 |
| Confirmation of fire alarm..... | 140 |
| Implementation of gasification of units..... | 140 |
| Implementation of building gas supply | 141 |
| wiring..... | 144 |
| Metal doors and warehouse doors | 159 |
| Welding of the rafters and around the roof | 159 |
| Common welding methods..... | 159 |
| Construction welding..... | 161 |
| Obtaining the end of the constructuon | 162 |
| Obtaining a construction permit (building permit)..... | 162 |
| Building facade..... | 163 |
| Types of facades for buildings | 164 |
| Facade in construction..... | 166 |
| Signing an elevator contract with standard approval | 167 |
| Digging a water well | 171 |
| (moisture insulation) What is bituminous waterproofing?..... | 176 |
| Obtaining water and sewage branches | 180 |
| Obtaining electrical power branch..... | 181 |
| Tiling | 185 |
| Floor preparation units | 185 |
| ceramic work | 187 |
| Plastering..... | 188 |
| The entrance doors of the unit or the installation of(...) | 193 |
| Aluminum windows and doors..... | 195 |
| Couple of skylights for the rafters | 198 |
| Wooden doors of the units..... | 199 |
| Closets | 202 |
| Cabinet and decor..... | 204 |
| Cabinet design principles in the building | 204 |
| Stair stonework..... | 205 |
| Stair railing welding | 208 |

| | |
|---|------------|
| Fondationlot mosaic and yard | 209 |
| Types of yard mosaics | 209 |
| Painting and wallpaper | 211 |
| Choosing wallpaper and affecting factors | 219 |
| building painting..... | 219 |
| Installation of windows and doors..... | 223 |
| Installation of sanitary faucets..... | 224 |
| Purchase of sanitary facilities of the building | 225 |
| Repair of apartment faucets..... | 230 |
| Installation of electrical switches and sockets, door phone(...)..... | 231 |
| Buying and installing a radiator | 234 |
| Installation of yard and parking doors..... | 237 |
| Who is the competent executive? | 244 |
| Conclusion of the contract of attorney for the(...) | 250 |
| | |
| Chapter two | 261 |
| Steel structure | 261 |
| Common structural forms..... | 262 |
| Standard metal structure | 263 |
| Steel frame..... | 266 |
| Types of metal building frames..... | 268 |
| Application and features..... | 270 |
| Components of the metal frame | 270 |
| Different types and grades of steel | 271 |
| Metal frame components | 272 |
| Moment and compression members..... | 272 |
| Types of steel structure..... | 274 |
| Steel structure foundation..... | 275 |
| The duty of the metal frame foundation | 276 |
| Types of metal frame foundations..... | 276 |
| Metal frame according to the type of material | 277 |
| Steel frame according to the production system..... | 279 |
| Comparison of concrete and steel structure..... | 284 |
| | |
| Chapter Three | 287 |
| Building standard | 287 |
| User restrictions..... | 288 |
| Considerations for the foundation of the structure | 290 |
| Grouping of buildings based on importance | 291 |
| Grouping buildings based on structural system..... | 292 |

| | |
|--|-----|
| Benefits of certification for the construction industry..... | 294 |
| Standard types of buildings | 295 |
| ISO 9001:2015 quality management systems | 296 |
| What is ISO 14001:2015 Environmental Management Systems? . | 297 |
| Integration of ISO 9001 and ISO 14001..... | 298 |
| ISO 14001 in construction industry..... | 300 |
| HSE-MS standard..... | 302 |
| CRM | 303 |
| 5S..... | 304 |
| Standard - SEIKETSU..... | 306 |
| ISO 12944 Corrosion protection of steel with protective paint..... | 307 |
| ISO 12944 standard | 307 |
| ISO standards related to building construction, general(.....) | 309 |
| The purpose of the building standard | 313 |
| The standard of building materials in Iran | 318 |
| What is the valid certificate of product standard and(.....)?..... | 318 |
| Who develops the standards? | 321 |
| International ISO issuance authorities..... | 322 |
| ISO..... | 324 |
| Standardization process | 327 |
| Types of eligible projects | 332 |
| Determinations | 333 |
| Green verifier..... | 333 |
| Green professional certificate | 334 |
| Smart building standards | 336 |
| Smart building equipment | 336 |
| BMS..... | 338 |
| Knx standard in building smartness | 340 |
| Introduction of BUS systems..... | 340 |
| History of KNX in BMS building smart system | 341 |
| A brief description of the KNX standard | 342 |
| About merged forums..... | 342 |
| Green building and energy management..... | 345 |
| Reducing environmental impacts | 347 |
| Life cycle assessment | 349 |
| Efficiency of site and structure design | 350 |
| Material performance | 352 |
| Cost and return | 355 |
| Setup and operation | 356 |
| International assessment frameworks and tools | 357 |

| | |
|---|-----|
| PSM FIDIC..... | 357 |
| Energy consumption in green buildings | 359 |
| New construction green buildings | 360 |
| Renovation of green buildings..... | 360 |
| Decreased demand in green buildings | 360 |
| Passive design in sustainable buildings | 360 |
| Green roofs and cool roofs in sustainable buildings..... | 361 |
| Energy efficient lighting in sustainable buildings | 361 |
| Production of renewable energy in green buildings | 361 |
| Benchmark, track and monitor green building energy | 362 |
| Net energy in green buildings..... | 362 |
| National Building Regulations | 363 |
| Rules of urban planning and construction | 363 |
| City view rules and regulations | 366 |
| Regulations for the construction of different parts of the(...) ... | 367 |
| Regulations for the construction of residential complexes..... | 368 |
| Municipal rules and important points in building design | 368 |
| The purpose of developing national building regulations | 370 |
| IMS | 373 |
| Business benefits of IMS..... | 374 |
| Integrated Management System (IMS) implementation steps ... | 375 |
| Types of permits and building permits and the(...)..... | 377 |
| Procedures for issuing permits and building permits | 378 |
| Building permit validity period | 381 |
| Reference standards..... | 383 |
| Copyright discussion | 383 |
| ICC building codes..... | 384 |
| Building code..... | 384 |
| Energy codes | 387 |

| | |
|---|------------|
| Chapter Four | 391 |
| Housing market in the world economy | 391 |
| Principles of design and architecture..... | 392 |
| Supermarket in architectural design principles | 394 |
| What are the principles of architectural design? | 394 |
| Some principles of special architectural design from the(...) ... | 398 |
| What is architecture? | 401 |
| Principles of architecture..... | 402 |
| HSE | 402 |
| HM Inspection of Mines..... | 404 |

| | |
|---|-----|
| OSHCR..... | 405 |
| Soil examination..... | 405 |
| Types of soil testing for building construction..... | 405 |
| What are the different tests to check the quality of concrete?..... | 410 |
| welding test..... | 415 |
| Why do we need a welding test? | 416 |
| Wedge Test..... | 431 |
| Testing of concrete and building materials | 434 |

| | |
|-------------------|------------|
| References | 439 |
|-------------------|------------|

The words of the authors

Today, when our dear country Iran is proud to win international honors in engineering sciences,

We decided to transfer a little bit of the vast sea of engineering sciences to those who loves this knowledge,

Now that the writing of the book ((International Building Standards Reference)) has been completed, it is hoped that in the implementation of engineering and development projects, the glory of our beloved country will be a reference for implementation.

Chapter One

Concrete buildings

A concrete structure is a structure that is made of concrete or usually reinforced concrete (cement, sand, gravel and steel in the form of simple or deformed bar). In a building, if reinforced concrete is used in the columns, beams and foundations, that building is considered a concrete structure.

Nowadays, many bridges are made of reinforced concrete. To use longer bridges and to increase the foundation distance of bridges, pre-stressed concrete beams are used.



Advantages of concrete structures

- 1- The main material of concrete, which is sand, is cheap and accessible.
- 2- Concrete structures that are designed and implemented in accordance with the principles of regulations are more resistant to harsh environmental conditions than structures made with other materials.
- 3- Due to the high plasticity of concrete, it is possible to build all kinds of concrete structures such as bridges, columns, etc. in different shapes.
- 4- Concrete structures are very resistant to high heat caused by fire. Experiments have shown that if a reinforced concrete sample is heated up to 1000 Celsius degrees, it takes at least one hour for the steel inside the concrete, which is covered with a 2.5 cm thick layer of concrete, to reach 500 Celsius degrees.

Design methods of reinforced concrete structures

In general, the purpose of designing a structure is to provide safety against collapse and ensure proper performance during operation. If the real resistance of a structure could be accurately predicted, and if the loads on the structure and their internal effects could be determined with the same accuracy, safety would be possible only by creating a carrying capacity that exceeds the amount of the loads. But there are many uncertain factors and possible errors in the analysis, design and construction of structures that demand a safety margin in the design of structures.

working-stress method

This method, which was previously called the service stress method or the service load stress method, is the first method that was used in a codified way for the design of reinforced concrete structures. In this method, a structural member is designed in such a way that the stresses caused by the effect of operating (or service) loads, which are calculated with the help of linear theories of solid mechanics, do not exceed the allowed values of stresses. Operational or service

loads are loads such as: live load, dead load, snow load and earthquake load. These loads are determined by the loading regulations, such as the sixth topic of the National Building Regulations Of Iran. In this method, allowable stress is the stress that is obtained by dividing the material's limit stress, such as compressive strength for concrete and yield strength for steel, by a factor greater than unity, known as the reliability factor. working-stress of materials are determined by calculation regulations. For example, according to ACI¹ regulations, the allowable compressive stress of concrete is $c \cdot 0.45$.

ultimate-strength method

The ultimate strength method, which is called the strength-based design method in the ACI regulations, is the result of extensive studies on the non-linear behavior of concrete and a detailed analysis of the safety issue in reinforced concrete structures.

Design based on limit states method

In order to develop the ultimate strength method, especially in terms of safety, the design method based on limit states was invented. This method is now the basis of design in a number of European codes, however, this method has not yet been able to replace the ultimate strength method in the ACI code. This method is similar to the design method based on resistance in terms of the principles of calculations related to resistance, and its main difference with the previous method is in the way of more rational evaluation of the bearing capacity and the probability of safety of the members. In this method, design requirements are determined by specifying limit states. Limit states are conditions in which the desired structure does not meet the design requirements. The design of the structure is done according to the following three limit states:

- 1: The ultimate limit state, which is related to the load capacity.
- 2: Deformation limit state (such as displacement and vibration of members)
- 3: Limit state of cracking or crack opening

Reference Book Of International Building Standards — Chapter One

1 American Concrete Institute

Concrete

Concrete is a composite material that consists of fine and coarse aggregates bonded together with fluid cement (cement paste) that hardens over time. Concrete is the second most used material in the world after water. It is the most widely used building material. It is used worldwide, ton for ton, twice as much as the combination of steel, wood, plastic and aluminum. Globally, the ready-mixed concrete industry, the largest segment of the concrete market, is expected to generate revenue of over \$600 billion by 2025. This widespread use leads to a number of environmental impacts. Most importantly, the cement manufacturing process produces a large amount of greenhouse gases, resulting in a net emission of 8% of global emissions. Other environmental concerns include illegal sand mining, impacts on the surrounding environment such as increased surface runoff or the urban heat island effect, and potential public health consequences from toxic materials.

Pouring concrete into rebar

When aggregate is mixed with dry portland cement and water, the mixture forms a fluid slurry that is easily poured and molded. Through a process called concrete hydration, cement reacts with water, which hardens within hours, forming a hard matrix that binds the materials together into a durable, stone-like material that has many uses. This time allows the concrete to not only be cast into the formwork, but a variety of tooling processes can be preformed. The hydration process is exothermic, which means that the ambient temperature plays an important role in the setting time of concrete. Often, additives (such as pozzolans or superlubricants) are included in the mix to improve the physical properties of the wet mix, delay or accelerate the curing time, or otherwise modify the final material. Most concrete is poured with reinforcing materials (such as rebar) embedded to provide tensile strength, and reinforced concrete is produced.

Placing concrete in cold weather

Extreme weather conditions (extreme heat or cold, wind conditions and changes in humidity) can significantly change the quality of concrete. Many precautions are taken in placing cold air. Low temperatures significantly slow down the chemical reactions involved in cement hydration, thus affecting strength development. Avoiding freezing is the most important precaution, as the formation of ice crystals can damage the crystalline structure of hydrated cement paste. If the poured concrete surface is insulated from the outside temperature, the heat of hydration prevents freezing.

Placement under water

Concrete may be placed and cured under water. Care must be taken in the placement method to avoid cement washing. Submersible placement methods include thermal, pumping, jump placement, manual placement using gusset bags, and bagging.

Grouted aggregate is an alternative method of underwater concrete mass formation in which molds are filled with coarse aggregate and then the voids are completely filled with pumped grout.

Roads

Concrete roads are more fuel efficient, more reflective, and last significantly longer than other paving surfaces, but have a much smaller market share than other paving solutions. Modern pavement methods and design practices have changed the economics of concrete pavements, such that a well-designed and placed concrete pavement will cost less upfront and be significantly cheaper over the life cycle.

Mass structures

Due to the exothermic chemical reaction of cement during setting, large concrete structures such as dams, navigation locks, large mat foundations, and large breakwaters generate excessive heat during hydration and the resulting expansion. To reduce these effects, post-cooling is usually used during construction. An early example at Hoover Dam used a network of pipes between vertical concrete

slabs to circulate cooling water during the curing process to prevent damage from overheating. Similar systems are still used. Depending on the pour volume, the concrete mix used and the ambient air temperature, the cooling process may continue for months after the concrete is placed. Various methods are also used to pre-cool the concrete mixture in mass concrete structures.

Another method for mass concrete structures that minimizes the thermal byproduct of the cement is to use roller concrete that uses a dry mix that requires much less cooling than conventional wet placing. It is deposited in thick layers as a semi-dry material, and then the roller is pressed into a dense and strong mass.

Types of concrete

Concrete is strong on the inside and beautiful on the outside. Concrete is a composite building material that is made from a combination of cement (usually Portland cement), water, coarse aggregates and fine aggregates.

From runways and bridges to patios and roads, concrete is an essential component of residential and commercial construction around the world.

Concrete is cast in many forms and is suitable for a wide range of uses.

Different construction needs require different types of concrete, such as plain concrete, precast concrete, prestressed concrete, ready-mixed concrete, air-entrained concrete, high-density concrete, lightweight concrete, reinforced concrete, stamped concrete, self-contained concrete. Consolidation, shotcrete and several types of concrete are being used.

In civil engineering, the use of concrete as a structural material is widespread and is known for the value offered by concrete and the versatility of its applications. The ratio of standard concrete mix (ordinary concrete) is 1:2:4:

- 1 part - cement

- 2 parts - sand

- 4 parts - materials

The above materials are mixed together and a stone-like paste is formed, which hardens over time and is ready for use in various structures. The proportion of components in a concrete mix varies based on construction requirements.

Sometimes, supplementary cementitious materials (SCM) are added to concrete mixes for key benefits such as reduced permeability and overall hardening of the concrete. For example, fly ash concrete is known to be a stronger concrete with improved durability.

Common types of concrete used in construction

Plain concrete

Plain concrete, also known as ordinary concrete, is used with a mixture ratio of cement, sand and aggregates of 1:2:4. Because plain concrete cannot withstand wind or vibration loading well, it is used for construction projects that do not require high tensile strength.

Normal strength concrete

Normal strength concrete is a quick setting mixture of aggregates, cement and water. The lack of tensile strength makes normal strength concrete suitable for buildings or pavements that do not require high tensile strength. Like plain concrete, ordinary strength concrete contains similar materials but varies in strength by 10-40 MPa.

Precast concrete

Precast concrete is concrete that is poured in one place for use in another place and is a mobile material. The majority of precast production is carried out at the works of specialist suppliers, although in some cases, due to economic and geographical factors, product scale or difficulty of access, elements are cast on or near the construction site. Prefabrication offers significant advantages because it takes place in a controlled environment, protected from the elements, but its downside is its contribution to greenhouse gas emissions from transportation to the construction site.

Precast concrete structures are built using cranes and special hooks are also considered for lifting them.

The applications of prefabricated concrete are:

- Drainage box under the road
- Bridge deck
- Concrete blocks
- tall buildings
- Rail links
- Retaining walls
- Acoustic walls
- Staircase units

Advantages of using precast concrete:

There are preferred dimension designs, with elements of tested designs available from a catalog.

Major time savings result from constructing structural elements separately from the set of events that determine the overall construction duration, known by planning engineers as the "critical path."

Availability of experimental facilities capable of performing the required control tests, many of which are certified for specific tests in accordance with national standards.

Equipment with appropriate capabilities for specific types of production, such as tension beds with appropriate capacity, molds and machines dedicated to specific products.

High-quality finishes obtained directly from the mold eliminate the need for interior decoration and ensure low maintenance costs.

Prestressed concrete

Prestressed concrete refers to industrial concrete that includes placing rods or tendons at the end of a structural unit before

applying concrete. This unit is subjected to compressive stresses during production to have a higher structural load capacity and to increase durability and tensile strength.

It is used in two different systems:

Prestressed concrete is almost always prefabricated and contains metal wires (tendons) that are held in tension while the concrete is placed and sits around them. Prestressed concrete has ducts running through it. After the concrete has hardened, the tendons are pulled through the ducts and put under pressure. Then the channels are filled with grout. Bridges built this way have experienced significant corrosion of the tendons, so external post-tensioning can now be used where the tendons run along the outer surface of the concrete. In prestressed concrete, prestressing is done using metal or polymer tendons or rods that are subjected to a tensile force before casting, or for post-stressed concrete, after casting.

Ready-mixed concrete

Ready-mixed concrete (RMC), also known as "mixed concrete", is produced in factories under controlled operations and transported to construction sites via trucks with in-transit mixers. When specialized precast concrete mixes are available, they only need to be poured on construction sites.

Unlike mixing concrete on site, ready-mixed concrete offers high precision and reduces job site confusion.

However, admixtures such as retarders are necessary to preserve ready-to-use concrete at construction sites far from the plants that produce and mix the concrete.

The upcoming changes in ready-mixed concrete are:

High Strength Concrete: The elasticity of this mix makes it an excellent choice for footers, heavy equipment foundations or heavy industrial loads.

Quick-Set Concrete: Since the mix hardens in 20-40 minutes, it works well for projects such as fences, mailboxes, small concrete

slabs, or any other construction project that requires quick-set concrete.

Fiber-reinforced concrete: Fiber-reinforced concrete is injected with microfibers or microfibers to make it more durable in harsh weather conditions such as very cold winters.

Self-leveling concrete: This mixture has high flow properties that allow the concrete to level itself without the need for additional water or manual leveling. Self-leveling concrete is suitable for projects that require smooth, even surfaces.

reinforced concrete

Reinforced concrete is a composite building material that is reinforced with metal bars that are inserted into the formwork during construction. Examples of this type of rebars include prefabricated metal cages and metal bars.

Reinforced concrete (RC) is a versatile composite and one of the most widely used materials in modern construction. It consists of different ingredients with very different properties that complement each other. In the case of reinforced concrete, the ingredients are almost always concrete and steel. These two materials create a strong foundation together and are able to withstand all kinds of forces and act effectively as a structural element.

Lightweight Concrete

Lightweight concrete, known as "cellular concrete" and "flowable concrete", is made from various aggregates such as clay, pumice, shale and scoria.

This easy-to-pour, self-leveling concrete with low thermal conductivity is used to build structures such as floor slabs, long-span bridge decks, and window panels.

Lightweight concrete is also used to protect metal structures and is made using lightweight aggregates, including:

Processed natural light aggregates: expanded clay, expanded shale and artificial shale.

Unprocessed natural light aggregates: Lafondacionelli, pozzolans and travertines.

Processed light industrial aggregates: expanded ash, expanded slag and artificial ash.

Unprocessed light industrial aggregates: blast furnace slag and pulverized fuel ash.

Permeable concrete

Permeable concrete, gives 15% to 20% void space of the concrete volume. Because permeable concrete is ideal for water passage, it is used in the construction of roads and pavements to recharge groundwater and solve drainage problems. For example, storm water can pass through a concrete pavement and reach groundwater without causing drainage problems.

Mehri concrete

Mehri concrete takes its name from stamping or placing a mold on hardening concrete to achieve a decorative concrete coating.

Once the floor has hardened, it is usually sealed to extend the life of the concrete mix. Sealed concrete is commonly used for concrete driveways, parking lots, pool decks, sidewalks, walkways, and other high traffic areas.

Aerated concrete

Aerated concrete is concrete in which air is introduced (injected) by adding a foaming agent such as foam or gas. The result is concrete with billions of microscopic air cells per cubic foot, with entrained air making up 3 to 6 percent of the concrete.

This method provides greater resistance to concrete against wear, wear and tear caused by freezing and melting, and scaling. In addition, it increases the efficiency of concrete without adding water. Common air absorbing agents include fatty alcohols, fatty acids and resins.

Asphalt concrete

Asphalt is a dark mineral composed of a mixture of hydrocarbons called bitumen. Asphalt concrete, also known as "asphalt" or "black top", is the concrete of choice for pavement works and projects such as runways, highways, parking lots, roads and sidewalks.

Shotcrete concrete

Shotcrete involves pumping "shot" concrete using a dry or wet mix method. In 1907, Carl Ackley invented the dry-mix shotcrete method, which uses a compressed air nozzle and injects water to shoot the dry mix against the wall.

In contrast, wet-mix shotcrete uses pre-mixed concrete to place more in less time without creating more waste or backing into the wall.

Lime concrete

Lime concrete, also known as "lime", uses lime and light aggregates such as glass fibers or sharp sand. Lime concrete is used to make the dome, floor and arch.

Lime is environmentally friendly because it is renewable, easy to clean, and absorbs carbon dioxide (as concrete does).

In addition, lime's ability to control moisture makes it possible to use natural products such as hemp, wood or straw without any risk of composting or spoilage.

Concrete impregnated with polymer

In polymer concrete, aggregates are bonded with polymer instead of cement. Common polymers include acrylics, epoxies, and urethanes. Polymer concrete, semi-saturated and polymer impregnated concrete (PIC) are popular types of polymer concrete.

In polymer-impregnated concrete, water-filled voids or water-filled pores form a large proportion of the total volume after normal curing of hardened concrete.

Once curing is complete, monomers such as acrylonitrile and styrene are injected into the cavities at high temperature, and then the cavities are packed through polymerization.

Glass concrete

Glass concrete is made from recycled glass and enhances the aesthetic appeal of a building structure while providing superior thermal insulation and strength.

Glass powder increases the workability of concrete and improves its hardening properties. As a result, glass concrete is easier to place and consolidate, saving money, energy and time.

The addition of glass aggregates can create visually appealing effects that range from glistening concrete to concrete with a granite or marble finish.

Self-compacting concrete

Self-compacting concrete (SCC), also known as self-consolidating concrete and zero-slump concrete, is composed of cement, coarse aggregates, and fine aggregates. In addition, SCC has mineral additives to modify viscosity and chemical additives to improve flowability and workability.

Applications of self-consolidating concrete include deep beams, heavy reinforcement, and dense reinforcement such as beam-to-column connections.

High density concrete

High Density Concrete (HDC) is made of coarse aggregates and crushed stones and has exceptional strength. Heavy aggregates use iron or barite. High-density concrete's ability to shield against radiation makes it the preferred choice of structural engineers for use in concrete structures that require additional shielding, such as power plants.

Vacuum concrete

Vacuum concrete is made by pouring more water than required into the mold. When a vacuum pump removes excess water before the

concrete sets, the concrete creates a vacuum that is ready for use sooner than with conventional construction techniques. This means that concrete reaches compressive strength in 10 days instead of 28 days.

Volumetric concrete

Bulk concrete is created by mixing water and concrete ingredients that are transported to the construction site by mobile bulk mixers. Volumetric concrete is especially useful for large project sites that require multiple types of concrete.

Decorative concrete

Raw concrete surfaces are porous and have a rather interesting appearance. Many coatings can be applied to improve the appearance and protect the surface against stains, water penetration and frost.

A popular effect for flooring and countertops is polished concrete, where the concrete is polished smooth with diamond abrasives and sealed with polymers or other sealants. Other finishes can be achieved by chiseling or by more conventional techniques such as painting or covering it with other materials.

History

Small-scale production of concrete-like materials was pioneered by Nabataean merchants who occupied and controlled a series of oases and established a small empire in southern Syria and northern Jordan from the 4th century BC. They took advantage of hydraulic lime with some self-cementing properties of foundations until 700 BC. They built kilns to prepare mortar for masonry houses, concrete floors, and underground waterproofing tanks. They kept the cisterns secret because they allowed the Nabataeans to thrive in the desert. Some of these structures have survived to this day.

Classical era

In ancient Egyptian and later Roman times, builders discovered that adding volcanic ash to the mix would seal it underwater.

Concrete floors were found in the royal palace of Tiryns, Greece, dating to approximately 1400-1200 BC. Lime mortar was used in Greece, Crete and Cyprus in 800 BC. The Assyrian Jarvan aqueduct (688 BC) used waterproof concrete. Concrete was used for construction in many ancient structures.

The Romans used concrete a lot from 300 BC to 476 AD. During the Roman Empire, Roman concrete (or Opus Caementicium) was made from quicklime, pozzolana, and pumice grains. Its widespread use in many Roman structures, a key event in the history of architecture called the Roman Architectural Revolution, freed Roman construction from the limitations of stone and brick materials. This enabled revolutionary new designs both in terms of structural complexity and dimensions. The Colosseum in Rome is made mostly of concrete, and the Pantheon has the largest unreinforced concrete dome in the world.

Concrete, as the Romans knew it, was a revolutionary new material. Arched, vaulted, and domed, the building quickly became a rigid mass, free of many of the internal stresses and strains that plagued builders of similar structures of stone or brick.

Modern tests show that opus comentissime has the same compressive strength as modern portland cement concrete (about 200 kg/cm²). It was different:

Modern structural concrete differs from Roman concrete in two important details. First, the consistency of the mix is fluid and homogenous, allowing it to be poured into shapes rather than requiring manual layering with placement of aggregates, which in Roman practice often consisted of rubble. Second, integrated reinforcing steel gives modern concrete assemblies great strength in tension, whereas Roman concrete depends only on the strength of the concrete foundation for tensile strength.

The long-term durability of Roman concrete structures is due to the use of pyroclastic (volcanic) stone and ash, through which

the crystallization of Stretlingite (a special and complex calcium aluminosilicate hydrate) and the cementation of this and calcium-

aluminum-silicate-hydrate cement binders. Similar to concrete, it provides greater degrees of resistance to failure even in seismically active environments. Roman concrete is significantly more resistant to erosion by seawater than modern concrete. In it, pyroclastic materials were used, which react with sea water and form albomorphite crystals over time.

The extensive use of concrete in many Roman structures made many of them survive to this day. The Baths of Caracalla in Rome is just one example. Many Roman aqueducts and bridges, such as the magnificent Pont du Gard in southern France, have masonry facings on a concrete core, as does the Pantheon dome.

After the fall of the Roman Empire, the use of concrete became rare until the technology was developed in the mid-18th century. All over the world, concrete has overtaken steel in the tonnage of consumables.

Medieval

After the Roman Empire, the use of quicklime and pozzolana was greatly reduced. Low kiln temperatures for burning lime, lack of pozzolana, and poor mixing all contributed to reduced quality of concrete and mortar. From the 11th century, the increased use of stone in church and castle construction led to an increased demand for mortar. Quality began to improve in the 12th century through better milling and sifting. Medieval lime mortars and concretes were non-hydraulic and were used to join masonry, "coring" (foundations of rubble masonry cores) and foundations.

Industrial era

Perhaps the greatest step forward in the modern use of concrete was Smeaton's Tower, built by British engineer John Smeaton in Devon, England, between 1756 and 1759.

A method for producing Portland cement was developed in England and patented by Joseph Aspdin in 1824. Aspdin chose

the name because of its similarity to Portland stone, which was quarried on the Isle of Portland in Dorset, England. His son

William continued the developments until the 1840s, giving him credit for developing "modern" Portland cement.

Reinforced concrete was invented in 1849 by Joseph Monier. And the first reinforced concrete house was built by Francois Cotillard in 1853. The first reinforced concrete bridge was designed and built by Joseph Monier in 1875.

Concrete composition

Concrete is a synthetic composite material consisting of a matrix of cementitious binder (usually Portland cement paste or asphalt) and a dispersed phase or aggregate "filler" (usually a rock material, loose rock, or sand). The binder binds the filler together to form a synthetic conglomerate. Many types of concrete are available, determined by the formulation of binders and types of aggregates used for the use of engineered materials. These variables determine the strength and density as well as the chemical and thermal resistance of the final product

Aggregates are large pieces of material in a concrete mix, generally a coarse gravel or crushed stone such as limestone, or granite, along with finer materials such as sand.

Cement paste, mostly made from Portland cement, is the most common type of concrete binder. To cement cement, water is mixed with dry cement powder and aggregates to produce a semi-liquid slurry (paste) that is usually poured into a shape. Concrete hardens through a chemical process called hydration. The water reacts with the cement, which binds the other components together and creates a solid, rock-like material. Other cementitious materials, such as fly ash and slag cement, are sometimes added (either premixed with cement or directly as a concrete component) and become part of the binder for the aggregate. Fly ash and slag can increase some properties of concrete such as fresh properties and durability. Alternatively, other materials can be used as concrete binders: the most common is asphalt substitutes, which are used as binders in asphalt concrete.

Additives are added to change the curing rate or properties of the material. Mineral admixtures use recycled materials as concrete

ingredients. Notable materials include fly ash, a byproduct of coal-fired power plants. Granulated blast furnace slag, a byproduct of steelmaking and silica soot, a byproduct of industrial electric arc furnaces.

Structures that use Portland cement concrete usually include metal reinforcements because this type of concrete can be formulated with high compressive strength but always has a lower tensile strength. Therefore, metal rebar is usually reinforced with materials that are strong in tensile strength.

Mixing design depends on the type of structure being built, how concrete is mixed and delivered, and how it is placed to form the structure.

Cement

Portland cement is the most common type of cement in general use. It is the main material of concrete, mortar and many plasters. British mason Joseph Aspedin patented Portland cement in 1824. This cement was named for its color similarity to Portland Limestone, mined from the English Isle of Portland and widely used in London architecture. It consists of a mixture of calcium silicates (allite, billite), aluminates and ferrites. Compounds that combine calcium, silicon, aluminum, and iron in forms that react with water. Portland cement and similar materials are made by heating limestone (a source of calcium) with clay or shale (a source of silicon, aluminum, and iron) and grinding this product (called clinker) with a sulfate source (usually gypsum).

In modern cement kilns, many advanced features are used to reduce fuel consumption per ton of clinker produced. Cement kilns in industrial facilities are very large, complex, and inherently dusty, with greenhouse gas emissions that must be controlled. Among the various materials that are used to produce a certain amount of concrete, cement is the most expensive in terms of energy. Even sophisticated and efficient kilns require 3.3 to 3.6 GJ of energy to produce one ton of clinker and then grind it into cement. Many

furnaces can be fueled with waste that is difficult to dispose of, the most common being used tires. Very high temperatures and long

periods of time at these temperatures allow cement kilns to efficiently and completely burn even difficult fuels.

Water

The combination of water with cement materials through the hydration process forms cement paste. The cement paste binds the aggregate together, filling the voids and making it flow more freely.

As stated by Abrams' Law, a lower water-cement ratio produces stronger, more durable concrete, while more water produces a freer-flowing concrete with more slump. Impure water used to make concrete can cause problems during setting or premature failure of the structure.

Portland cement consists of five main compositions of calcium silicates and aluminates ranging from 5 to 50% by weight, all of which are hydrated to aid in the strength of the final material. Therefore, cement hydration involves many reactions that often occur at the same time. As the reactions continue, the products of the cement hydration process gradually bind the sand particles and other concrete components together to form a solid mass.

Hydration of tricalcium silicate



Standard symbol:

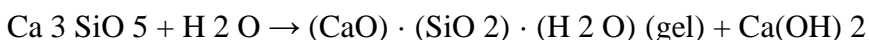

balanced:

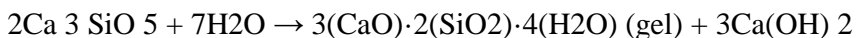

(approximate; the exact proportions of CaO, SiO₂ and H₂O in CSH can vary)

Considering the nature of the chemical foundations created in these reactions and the final characteristics of the formed particles, the cement hydration process is considered irreversible, which inhibits cement recycling methods.

Construction Materials

Crushed aggregate

Fine and coarse aggregates make up most of the concrete mix. For this purpose, sand, natural gravel and crushed stone are mainly used. Recycled aggregates (from construction, demolition and excavation waste) are increasingly used as partial substitutes for natural aggregates, while a number of manufactured aggregates, including air-cooled blast furnace slag and bottom ash are also allowed.

The size distribution of the aggregate determines how much binder is needed. Aggregate with a very uniform size distribution has the most gaps, while the addition of aggregate with smaller particles fills these gaps. The binder must fill the gaps between the aggregates and also bond the aggregate surfaces together and is usually the most expensive component. Therefore, the change in aggregate size reduces the cost of concrete. Aggregate is almost always stronger than adhesive, so its use does not negatively affect the strength of concrete.

Redistribution of aggregates after compaction often causes inhomogeneity due to the effect of vibration. This can lead to a power gradient.

Decorative stones such as quartzite, small river rocks, or crushed glass are sometimes added to the surface of the concrete to create a decorative "exposed aggregate" coating that is popular with landscape designers.

additives

Admixtures are substances in the form of powders or liquids that are added to concrete to give it special properties that cannot be achieved with plain concrete mix. Admixtures are defined as additives "made during the preparation of the concrete mix". The most common additives are retarders and accelerators. In normal use, admixture dosages are less than 5% by mass of cement and are added to the concrete during batching/mixing.

Accelerators speed up the hydration (hardening) of concrete. Commonly used materials are calcium chloride, calcium nitrate and sodium nitrate. However, the use of chlorides may cause corrosion in metal reinforcement and is prohibited in some countries, so that nitrates may be preferred, even though they are less effective than chloride salts. Accelerating admixtures are particularly useful for modifying the properties of concrete in cold weather.

Air encapsulating agents add tiny air bubbles into the concrete, reducing damage during freeze cycles and increasing durability. However, entrained air requires a strength trade-off, as every 1% of air may reduce compressive strength by up to 5%. If too much air is trapped in the concrete as a result of the mixing process, defoamers can be used to encourage the air bubbles to agglomerate, rise to the surface of the wet concrete, and then disperse.

Bonding agents are used to create a foundation between old and new concrete (usually a type of polymer) with extended temperature tolerance and corrosion resistance.

Corrosion inhibitors are used to minimize corrosion of steel and metal bars in concrete.

Crystalline admixtures are usually added during concrete batching to reduce permeability. This reaction takes place when exposed to water and unhydrated cement particles, forming insoluble needle-shaped crystals that fill the capillary pores and microcracks of the concrete to block water pathways and contaminants in the water. Concrete with a crystalline admixture can be expected to be self-sealing as continuous exposure to water continuously begins to crystallize to ensure permanent waterproof protection.

Pigments can be used to change the color of concrete for aesthetics.

Plasticizers increase the workability of plastic or "fresh" concrete, allowing it to be placed more easily and with less consolidation effort. A common softener is lignosulfonate. Softeners can be used to reduce the water content of concrete while maintaining workability, and are sometimes called water reducers for this use. Also, the treatment improves its strength and durability characteristics.

Superplasticizers (also called high-range water reducers) are a class of softeners that have less harmful effects and can be used to increase performance more than traditional softeners. Superlubricants are used to increase compressive strength. It increases the efficiency of concrete and reduces the need for water by 15-30%.

Pumping aid improves pumpability, thickens the dough and reduces separation and bleeding.

Retarders slow the hydration of concrete and are used in large or hard pours where partial setting before completion of pouring is undesirable. Common polyol inhibitors are sugar, sucrose, sodium gluconate, glucose, citric acid and tartaric acid.

Concrete production

Concrete production is the process of mixing different materials like water, aggregate, cement and any additives, to produce concrete. Concrete production is time sensitive. After the materials are mixed, workers must place the concrete before it hardens. In modern usage, most concrete production takes place in a large type of industrial facility called a concrete plant or often a batch plant.

In general, concrete plants come in two main types, ready-mix plants and central batch plants. A ready mix plant mixes all ingredients except water, while a central mix plant mixes all ingredients including water. A central mixing plant provides more precise control over concrete quality through better metering of the amount of water added, but must be located closer to the job site where the concrete is used, as hydration begins at the plant.

Modern concrete is usually prepared as a viscous fluid, so that it may be poured into forms, which are containers that are installed in the field to give the concrete its desired shape. Concrete formwork can be prepared in various ways, including sliding and sheet metal construction. Alternatively, concrete can be mixed in dry and non-fluid forms and used in a factory setting to produce precast concrete products.

A wide variety of equipment is used for concrete processing, from hand tools to heavy industrial machinery. However, whatever equipment the builders use, the goal is to produce the desired building material. Materials must be properly mixed, placed, shaped and kept within time constraints. Any interruption in the pouring of the concrete can cause the first placed material to begin to set before the next batch is added to the top. This creates a horizontal plane of weakness called a cold junction between the two bundles. Once the mix is where it needs to be, the curing process must be controlled to ensure that the concrete achieves the desired properties. During the preparation of concrete, various technical details may affect the quality and nature of the product.

Design composition

Design mix proportions are decided by an engineer after analyzing the properties of the specific ingredients used. Instead of using a "nominal mix" of 1 part cement, 2 parts sand, and 4 parts aggregate, a civil engineer custom designs a concrete mix to exactly meet the site's needs and conditions. Adjusting the ratio of ingredients and often designing an additive package to fine-tune the properties or increase the performance of the mixture. Mix design concrete can have very wide specifications that cannot be met with nominally more foundational mixes, but the engineer's involvement often increases the cost of the concrete mix.

Concrete mixes are primarily divided into nominal mix, standard mix and design mix.

Various governing bodies (such as British Standards) define nominal mix ratios into a number of grades, usually ranging from lower compressive strength to higher compressive strength. Degrees usually represent the strength of a 28-day cube.

mix

Separate paste mixing has shown that mixing cement and water in a paste form before combining these materials with aggregates can increase the compressive strength of the resulting concrete. The

paste is generally mixed in a high-speed, shear-type mixer at a w/c (water-cement ratio) of 0.30 to 0.45 by weight. The cement paste

premix may contain additives such as accelerators or retarders, superplasticizers, pigments or silica fume. The premixed paste is then mixed with aggregates and the remaining batch water and final mixing is completed in conventional concrete mixing equipment.

Concrete slump test

Workability is the ability of a fresh (plastic) concrete mix to fill the form/mould adequately for the intended work (pouring, pumping, spreading, impacting, vibration) without reducing the quality of the concrete.

Performance can be measured by the concrete slump test, a simple measurement of the plasticity of a fresh batch of concrete in accordance with ASTM C 143 or EN 12350-2 test standards.

Slump is usually measured by filling an Abrams cone with a sample from a batch of fresh concrete. The cone is placed with the wide end downwards on a level and non-absorbable surface. Then it is filled in three layers with equal volume and each layer is beaten with a metal rod. When the cone is carefully lifted, the enclosed material collapses to a certain amount due to gravity. A relatively dry sample slumps very little and has a slump value of one or two inches (25 or 50 mm) of one. ft. (300 mm) of a relatively wet concrete sample may slump as much as 8 in. Efficiency can also be measured by flow chart testing.

Slump can be increased by adding chemical additives such as softener or superplasticizer without changing the water-cement ratio. Some other admixtures, especially air entraining admixtures, can increase the slump of a mix.

High-flow concrete, such as self-consolidating concrete, is tested by other methods of flow measurement. One such method involves placing the cone at the narrow end and observing how the mixture flows inside the cone as it gradually rises.

Cooking

Concrete must be kept moist during curing to achieve optimal strength and durability. During curing, hydration occurs, allowing calcium silicate hydrate (CSH) to form. More than 90% of the

ultimate strength of a mixture is usually achieved within four weeks, and the remaining 10% is achieved over years or even decades. The conversion of calcium hydroxide in concrete to calcium carbonate caused by the absorption of CO₂ over several decades strengthens concrete and makes it more resistant to damage. These carbonates reduce the reaction, the pH of the cement pore solution and can corrode the reinforcing bars.

Hydration and hardening of concrete are very important in the first three days. Abnormally rapid drying and shrinkage due to factors such as wind evaporation during placement may lead to increased tensile stresses when it has not yet achieved sufficient strength, resulting in further shrinkage cracking. If the concrete is kept moist during the curing process, the initial strength of the concrete can be increased. Minimizing stress before curing minimizes cracking. Early-strength concrete is designed to hydrate more quickly, often by increasing the use of cement, which increases shrinkage and cracking. The strength of concrete changes (increases) up to three years. It depends on the cross-sectional dimensions of the elements and the operating conditions of the structure. The addition of short-cut polymer fibers can improve (reduce) the stresses caused by shrinkage during curing and increase the initial and final compressive strength.

Proper curing of concrete leads to increased strength and lower permeability and prevents cracking where the surface dries prematurely. Care should also be taken to avoid freezing or overheating due to cement exothermic setting. Improper curing can cause flaking, reduced strength, poor wear resistance and cracking.

Technique

During the curing period, concrete is ideally kept at a controlled temperature and humidity. To ensure complete hydration during curing, concrete slabs are often sprayed with "curing compounds" that create a water-retaining film on the concrete. Conventional films are made of wax or related hydrophobic compounds. After the concrete has sufficiently cured, the film is allowed to be rubbed off the concrete with normal application.

Traditional conditions for curing include spraying or sprinkling the concrete surface with water. The adjacent image shows one of the many ways to achieve this, soaking the concrete in water and wrapping it in plastic to prevent dehydration. Common additional treatment methods include wet mulch and plastic sheeting covering fresh concrete.

For higher strength applications, accelerated curing techniques may be applied to the concrete. A common technique involves heating the poured concrete with steam, which both keeps it moist and raises the temperature to make the hydration process faster and more complete.

Asphalt concrete

Asphalt concrete (commonly called asphalt, blacktop, or paving in North America, and asphalt, bitumen macadam, or rolled asphalt in the United Kingdom and the Republic of Ireland) is a composite material commonly used to surface roads, parking lots, and more. Airports as well as the core of earthen dams. Asphalt mixture has been used in pavement construction since the beginning of the 20th century. It consists of mineral aggregates that are bonded together with asphalt, placed in layers and compacted. This process was refined and enhanced by Belgian inventor and American immigrant Edward D. Smedt.

The terms asphalt concrete (or bituminous), bituminous asphalt concrete, and bituminous mix are usually used only in engineering and construction documents that define concrete as any composite material consisting of mineral aggregates held together by an adhesive.

Graphene reinforced concrete

Graphene-reinforced concretes are standard designs of concrete mixes, except that a small amount of chemically engineered graphene (typically less than 0.5% by weight) is added during the cement mixing or manufacturing process. These reinforced graphene concretes are designed for concrete applications.

microbial

Bacteria such as *Bacillus pasteurii*, *Bacillus pseudofirmus*, *Bacillus cohnii*, *Sporosarcina pasteurii* and *Arthrobacter crystallopoietes* increase the compressive strength of concrete through their biomass. However, some forms of bacteria can also degrade concrete. *Bacillus* sp. CT-5. It can reduce the corrosion of reinforcement in reinforced concrete up to four times. *Sporosarcina pasteurii* reduces water and chloride permeability. *B. pasteurii* increases acid resistance. *Bacillus pastori* and *B. sphaericus* can cause calcium carbonate deposition on the crack surface and increase the compressive strength.

Nano concrete

Nano-concrete is a group of materials that contains Portland cement particles with a thickness of 100 micrometers and silica particles of more than 500 micrometers that fill the voids. Otherwise, it occurs in ordinary concrete, thereby significantly increasing the strength of the material. It is widely used in footbridges and highways that have high moment and compressive strength.

Transient concrete

Pervious concrete is a combination of specially graded coarse aggregate, cement, water and very little fine aggregate. This concrete is also known as "no fine" or porous concrete. Mixing the ingredients in a carefully controlled process creates a paste that coats and binds the aggregate particles together. Hardened concrete contains inter-foundation air voids, which total approximately 15-25%. Water goes through the holes in the pavement to the soil below. Air-entraining additives are often used in freeze-thaw climates to minimize the potential for frost damage. Pervious concrete also allows rainwater to flow through roads and parking lots to recharge aquifers instead of contributing to runoff and flooding.

polymer

Polymer concretes are a mixture of aggregate and any of the different polymers and may be reinforced. Cement is more

expensive than lime cements, but polymer concretes have advantages. They have significant tensile strength even without reinforcement and are largely impervious to water. Polymer concretes are often used for repair and construction of other applications such as drainage.

Volcanic

Volcanic concrete replaces volcanic rocks with limestone that is burned to form clinker. It consumes a similar amount of energy, but does not directly emit carbon as a byproduct. Volcanic rock/ash is used as supplementary cementitious materials in concrete to improve resistance to sulfate, chloride and alkali silica reactions due to pore refinement. Also, they are generally cost-effective compared to other aggregates, for semi- and lightweight concretes, and good for thermal and sound insulation.

Light concrete waste

Waste light is a form of polymer modified concrete. The special polymer mixture allows all traditional aggregates (gravel, sand, rock) to be replaced with any mixture of solid waste materials in the grain size of 3-10 mm to create a low compressive strength (3-20 N/mm). . One cubic meter of waste lightweight concrete contains 1.1 to 1.3 cubic meters of crushed waste and no other aggregates.

Sulfur concrete

Sulfur concrete is a special concrete that uses sulfur as an adhesive and does not need cement or water.

Properties of concrete

Concrete has relatively high compressive strength, but much lower tensile strength. Therefore, it is usually reinforced with materials that are strong in tensile strength (often steel). The elasticity of concrete is relatively constant at low stress levels, but at higher stress levels it starts to decrease with the formation of ground cracking. All concrete structures crack to some extent due to contraction and tension. Concrete subjected to long-term forces is prone to creep.

Tests can be performed to ensure that the properties of the concrete meet the application specifications.

The ingredients affect the strength of the material. Concrete strength values are usually specified as the lower compressive strength of a cylindrical or cubic specimen determined by standard test methods.

The strength of concrete is determined by its performance. When the concrete must be lightweight, very low strength concrete of 14 MPa (2000 psi) or less can be used. Lightweight concrete is often obtained by adding air, foam or lightweight aggregates, and this has the side effect of reducing strength. For most common applications, 20 to 32 MPa (2,900 to 4,600 psi) concrete is often used. 40 MPa (5800 psi) concrete is readily available on the market as a more durable, albeit more expensive, option. Higher strength concrete is often used for larger construction projects. Strengths higher than 40 MPa (5800 psi) are often used for certain structural elements. For example, lower-story columns of tall concrete buildings may use 80 MPa (11,600 psi) or more concrete to keep columns small. Bridges may use long high-strength concrete girders to reduce the number of spans required. Sometimes, other structural needs may require high strength concrete. If a structure must be very rigid, very high strength concrete may be specified, even much stronger than what is required to carry the service loads. For these reasons, strengths up to 130 MPa (18,900 psi) have been used commercially.

energy efficiency

The energy required to transport concrete is low because it is produced locally from local sources, usually within 100 km of the job site. Similarly, relatively little energy is used in the production and mixing of raw materials (although large amounts of CO₂ are produced by chemical reactions in cement production). Therefore, the overall energy of concrete is about 1 to 1.5 megajoules per kilogram less than most structural and building materials.

fire safety

Concrete buildings are more fire resistant than steel framed buildings because concrete has a lower thermal conductivity than steel and therefore can last longer under the same fire conditions.

Concrete is sometimes used as fire protection for steel frames, to the same effect as above. Concrete as a fire shield, for example Fondu fyre, can also be used in extreme environments such as rocket launch pads.

Safety against earthquakes

As explained above, concrete is very strong in compression, but weak in tension. Larger earthquakes can cause very large shear loads on structures. These shear loads expose the structure to both tensile and compressive loads. Unreinforced concrete structures, like other unreinforced masonry structures, may fail during strong earthquake shaking. Unreinforced masonry structures are one of the biggest earthquake hazards in the world. These risks can be reduced through seismic retrofitting of vulnerable buildings (such as school buildings in Istanbul, Turkey).

Environmental effects of concrete

The production and use of concrete creates a wide range of environmental, economic and social effects.

Concrete, cement and environment

One of the main components of concrete is cement, a fine, soft, powdery substance that is mainly used to bind fine sand and coarse aggregate together in concrete. Although there are many types of cement, the most common is Portland cement, which is produced by mixing clinker with smaller amounts of other additives such as gypsum and ground limestone. The production of clinker, the main ingredient of cement, is responsible for the major greenhouse gas emissions in this sector, including energy intensity and process emissions.

Concrete and climate change mitigation

Reducing the cement clinker content may have positive effects on the environmental life cycle assessment of concrete. Some research work on reducing cement clinker content in concrete has already been done. However, there are different research strategies. Often the

replacement of clinker for large amounts of slag or fly ash based on conventional concrete technology was investigated. This can

lead to wastage of scarce raw materials such as slag and fly ash. Another goal of research activities is the efficient use of cement and reactive materials such as slag and fly ash in concrete based on a modified mix design approach.

Concrete and adaptation to climate change

High-performance building materials will be especially important to increase resilience, including for flood defenses and protecting critical infrastructure. The risks to infrastructure and cities from extreme weather events are particularly serious for places prone to flood and storm damage, but also where residents need protection from extreme summer temperatures. Traditional concrete is stressed when exposed to moisture and higher concentrations of atmospheric CO₂. While concrete is likely to remain important in applications where the environment is challenging, new, smarter and more adaptable materials are also needed.

Concrete, health and safety

Recycled crushed concrete is loaded into a semi-dump truck for reuse as aggregate.

Concrete grinding can produce hazardous dust. Exposure to cement dust can lead to problems such as silicosis, kidney disease, skin irritation and similar effects. The National Institute for Occupational Safety and Health in the United States recommends attaching local exhaust ventilation hoods to electric concrete mixers to control the spread of this dust. Additionally, the Occupational Safety and Health Administration (OSHA) has imposed stricter regulations for companies whose workers are regularly exposed to silica dust.

Circular economy

Concrete is an excellent material that can be used to build durable and energy-efficient buildings. However, even with good design, human needs change and potential waste is produced.

Destruction of concrete

Concrete can be damaged by many processes, such as expansion of corrosion products of steel reinforcing bars, freezing of trapped

water, fire or radiant heat, expansion of aggregates, seawater effects, bacterial corrosion, washing, erosion by fast-flowing water, physical damage, and chemical damage (from carbonation, chlorides, sulfates, and distilled water).

Reuse of concrete

Reusing the blocks in their original form, or by cutting them into smaller blocks, has a lower environmental impact. However, there is currently only a limited market. Improved building designs that allow for reuse of slabs and alteration of buildings without demolition can increase this use. Hollow concrete slabs are easy to remove and the opening is usually fixed and suitable for reuse.

Concrete recycling

Concrete recycling is a common way to dispose of concrete structures. Concrete waste was once routinely sent to landfills for disposal, but recycling is increasing due to improved environmental awareness, government regulations, and economic benefits.

Contrary to popular belief, concrete recovery is achievable - concrete can be crushed and reused as aggregate in new projects.

Concrete recycling reduces the exploitation of natural resources and associated transportation costs and reduces landfill. However, it has little impact on reducing greenhouse gas emissions because most emissions occur when cement is made and cement itself cannot be recycled. Currently, most recycled concrete is used for road infrastructure projects and civil engineering projects. From a sustainability perspective, these relatively low-grade uses currently provide the optimal result.

Applications of recycled concrete aggregate

The main commercial applications of final recycled concrete aggregate are:

Path aggregate foundation (road foundation) or unrefined aggregates used as foundation for road paving is the sub-layer (pavement sub-pavement) that forms the structural foundation for

the pavement. To date this has been the most popular program for RCA due to techno-economic aspects.

Aggregate for ready-mixed concrete is made by replacing 10 to 45% of natural aggregates in the concrete mix with a mixture of cement, sand and water. Some conceptual buildings show the progress of this field. Because RCA contains cement, mix proportions must be adjusted to achieve desired structural requirements such as workability, strength, and water absorption.

Soil stabilization, by incorporating recycled aggregate, lime, or fly ash into marginal quality materials used to increase the load bearing capacity of that substrate.

Tubular bed: as a fixed bed or solid foundation on which underground facilities are placed. Regulations in some countries prohibit the use of RCA and other construction and demolition waste in filtration and drainage beds due to possible chromium contamination and pH value effects.

Landscape Materials: To promote green architecture, till date, recycled concrete aggregates have been used as boulder/rock walls, underpass support structures, erosion structures, water features, retaining walls, etc.

Rebars and its types

The main purpose of implementing reinforcement in small and large buildings is to prevent and minimize concrete cracks under the influence of tensile forces. You must know that concrete has good resistance against compressive forces. But it does not have the necessary endurance against tensile and shearing forces. Therefore, in order to increase the tensile strength of structures, it is necessary to perform reinforcement. In this operation, concrete and reinforcement (rebar) with appropriate sizes should be combined based on engineering principles. In the method of strengthening the roof, columns and foundation, reinforcing wire is used to keep the bars together.



An example of armatures

The concept of rebar

Reinforcement (reinforcing rebar) is actually a type of rebar that is used to prepare reinforced concrete. Reinforcing bars help prevent cracks in the concrete that can cause the building to collapse. The diameter of all types of rebar is between 6 and 50 mm. In different structures, according to the performance of rebar, they choose the right diameter. Usually, rebars with a diameter of 8 to 32 mm are used for reinforcement.

Types of reinforcement: When it comes to concrete reinforcement, the most important thing that occupies the minds of engineers is choosing the right rebar. Therefore, in this part, we decide to talk about the types of reinforcements that increase the tolerance of concrete against tensile and shear forces.

Soft rebar without tread (A1)

This type of reinforcement is placed in the category of soft and non-treaded rebars. According to their specifications, they are suitable for welding and forging. A1 rebars have a resistance rating of 240. These rebars have a smooth surface and no tread, so they are mostly used as screws in the implementation of reinforcement.

semi-hard rebar (A2)

A2 rebars are part of ribbed reinforcements, which are mostly seen in single and parallel form. Due to its ability to cut, it is used as an

anchor and mesh in construction projects. They are in the S340 category and are not suitable for much welding.

Hard rebar (A3)

This type of cross-ribbed rebars is harder than the previous two types and belongs to the category of semi-hard reinforcements. According to the physical and chemical properties of A3 rebars, they are used in building construction as longitudinal bars for beams and columns and roof reinforcement. Be careful, these semi-hard bars are not designed for welding.

Rebar with compound tread (A4)

It is part of hard rebars and is less useful compared to A3 construction rebars. All types of A4 reinforcements are in the S500 category, generally suitable for use in heavy construction projects. Of course, shear walls and extinguishing devices are not used in the implementation of reinforcements.

Types of reinforcements in the structure in terms of placement

Two types of longitudinal and transverse rebar are used in retrofitting different structures. Rebars that are placed horizontally or longitudinally in line with beams and columns of the upper and lower rows are called longitudinal reinforcement. While the bars that are placed transversely and in order to increase the tensile strength of reinforced concrete are called transverse reinforcement or khamut. To keep the transverse reinforcements strong, bending operations are performed on them. At the same time, they connect longitudinal and transverse rebars with the help of reinforcement wire.

Steps and principles of implementation of reinforcement

One of the important stages in the construction of modern and resistant structures is reinforcement, which consists of seven stages. Reinforcement must be done before concreting, and after the necessary checks and approval, it is time to concretize. In any project, the reinforcement team is required to perform the following steps.

Step 1: Building plan design

The architect must first prepare a complete plan of the building with all its details. Without the design of the building plan, many problems arise during the project and retrofitting. In the building plan, the dimensions of columns, beams, foundation, etc. must be calculated correctly. Also, the location of the reinforcements and their distance from each other should be specified. The number of reinforcements and determining their size is also one of the tasks of the architect, which is considered in the design phase of the building plan.

Step 2: Purchase rebar

As we said, in the first stage of reinforcement implementation, all the specifications of the types of reinforcement needed for the desired project are determined. Therefore, based on the specified information, it is necessary to buy reinforcement with the required number and size.

Step 3: Checking the rebars

The selection of rebars is very important in the quality and increase of tensile strength of concrete and consequently the strength of the structure. Therefore, it is necessary to check the health and quality of reinforcements. Inspection of rebars in roof reinforcement, columns, beams and foundation is mandatory and is done by supervising engineer. Performing this step in large construction projects is more sensitive.

Step 4: Prepare the reinforcement equipment

In the introduction of reinforcements, we stated that they are a type of rebar that has undergone changes. Undoubtedly, special tools and facilities are needed for bending, cutting and any changes in the structure and size of rebars, which must be prepared in advance at the project site.

Step 5: Choosing the right reinforcement method

It is very important to keep the rebar firmly in place of the reinforcement. They usually do this using reinforcing wire. There

are many ways to strengthen. For example, it is done in the form of a knot, a tie and regular.

Step 6: Implement reinforcement

After completing all the above steps, it is time to place the reinforcement. At this stage, all the necessary actions must be done according to the building plan. The reinforcement team must be completely professional and aware of all the details and principles. After the end of this stage, the supervising engineer is obliged to check the armatures and their connection method again and send an order to correct them in case of any problems and failures.

Step 7: Molding and concreting

There are different ways to pour concrete. After choosing the appropriate mold and placing it in place of the reinforcements, it is time to pour concrete. The concreting operation has special conditions that must be carried out precisely. In large projects, the use of ready-mixed concrete is preferred most of the time.

Implementation of roof reinforcement

It is important to increase the strength of the structure in all its parts. The roof of the building is one of the important parts of any structure for which the implementation of reinforcement is considered a necessity and in a way it can be said that it has the role of carrying the building. One of the important advantages of roof reinforcement is its high resistance to fire, water and earthquake. It also preserves the original shape of the building, creates different shapes for the concrete, reduces costs and prevents cracking. There are various types of ceiling reinforcements, including block beam ceiling reinforcement, chromite ceiling reinforcement, concrete slab ceiling reinforcement, and Kubiak ceiling reinforcement.

Splice reinforcement

Splice reinforcement is always one of the most important things in the implementation of concrete skeletons. In the implementation of the concrete skeleton, there are parts where the length of the rebar is

over or the length of the rebar needs to be cut. In these cases, the new rebars must be patched to the old rebars.

Types of reinforcement patches

1- Cover

Overlap in columns is performed by placing two rebars together in a part of their length. The length that two rebars should be placed together is called cover length. Overlap is allowed only for rebars with a diameter of less than 36 mm.

Why are Orlab connections not suitable for patching reinforcements?

Armatures will not align perfectly.

Reinforcement will be difficult because the rebars are not exactly aligned.

It is difficult for Etisalat Orlab to comply with all legal parameters.

Limitation in design and uncertainty of connections

In sections with high reinforcement density, instead of using a cover patch, you can use a mechanical patch (coupling) or a welding patch (forging).

This work reduces the density of the reinforcements, aligns them along their axis, provides sufficient strength and proper plasticity, prevents the concrete from becoming brittle, saves rebar and reduces costs.

2- Welding splice

The welding patch to patch the reinforcements is done by welding two rebars to each other in the following two ways:

A) Forging

The tip-to-tip welding connection of the paste, which is called contact electric welding and is known as forging operation. If the forging is performed correctly, the breaking point in the tensile test will be outside the patch area.

Forging connection is allowed only if the diameter of the bars is not less than 10 mm for hot rolled steels and 14 mm for cold modified steels.

Also, the diameter of the two connecting rods should be proportional to each other and the cross-sectional area ratio of the two connecting rods should not exceed 1.5.

In the forging method, the two ends of the armature are fried by the flame of oxygen and acetylene gas to a temperature of about 1200 to 1300 degrees Celsius and become a paste.

Then the two armatures are joined together by a hydraulic jack with appropriate pressure. The amount of pump pressure should be such that the diameter of the welding area reaches about 1.4 times the initial diameter of the armature.

Important points of welding forging in the splice of reinforcements

For the correct implementation of forging, the two ends of the rebars must be cut completely flat and perpendicular to the longitudinal axis and placed in the clamp in such a way that they do not slip. When placing the reinforcements in the clamp, the tip of the screw should not be closed on its tread.

The tip of the screw should be closed between the two treads of the rebar so that the rebars do not slip and the weld does not deviate from the standard position in case of pressure.

To create uniform heating, the flame should be completely perpendicular to the armatures and the rebars should be patched together in the center of the flame. This heating continues until the joint and its surroundings turn into a paste and are fried.

Pouring water on the forging welding area will cause the steel to crack and become brittle, so avoid doing this.

Considering that it is not possible to perform non-destructive tests such as ultrasonic on the forging connection, it is necessary to visually inspect all the patches.

From the part of the welding seam, which is the thickest part, to the main diameter of the rebar, it should have a gentle and uniform slope. The lack of a uniform slope can be due to the pump pressure not being adjusted or the burner overheating.

Before welding the main reinforcements, it is better to prepare some samples and perform a bending test using a hydraulic bender.

The samples are bent by the jack from the welding point to 90 degrees, the absence of cracks or fractures in the forging welding point indicates the correctness of the connection.

For more certainty, some samples can be sent to the laboratory for tensile testing. The place of rupture in the tensile test should be outside the welded area.

B) fusion welding connection with electrode (electric-arc welding)

This type of connection is only used for non-structural elements, such as the connection of joint reinforcements when the reinforcement is used instead of copper wire or the connection of column frames. In order for the connection to be done correctly, for each type of steel, the appropriate electrode and welding method should be used. The fusion welding connection with the electrode is usually done in one of the following ways:

Side-to-side welding connection with welding from one side or two sides:

Allowed only for hot-rolled bars with a diameter of 6 to 36 mm. In this method, the length of one-sided welding tape should not be less than 10 times the diameter of the rebar, and the length of the double-sided welding tape should not be less than 5 times the diameter of the smaller rebar.

Welded connection with patch or additional side patches with welding on one side or two sides:

This type of connection is only allowed for hot rolled bars. The minimum length of the welding strip is the same as the side-to-side welding joint.

Butt-to-butt welding connection with back strap:

The length of the back strap should not be less than 3 times the diameter of the bars for hot rolled steels or 8 times the diameter of the bars for cold worked steels.

3- Mechanical splice

Another method of splicing reinforcements is coupling, which is done by using special mechanical devices such as couplers.

Due to the fact that the quality control of the coupling connections is done in the factory, in case of using quality products and correct implementation, it is possible to ensure the correct operation and the occurrence of failure outside the scope of the couplings.

Rebar splices, standard coupler

Another method of patching armatures is to use a standard coupler. The standard coupler is one of the most common types of couplers for connecting the coupling of armatures with the same diameter.

It is used when at least one of the armatures can rotate. The internal threads on both sides of this type of coupler are straightened and completely tightened by turning.

Rebar splices, conversion coupler

This type of coupler is used to connect two armatures with different diameters. To connect both sizes of armature, you must use a special coupler of the same sizes.

Rebar splices, end coupler

This type of coupler is used as an alternative method for those cases where it is not possible to provide the restraining length in concrete by creating an end bend.

Rebar splices, screw coupler

This type of coupler is used in places where it is not possible to create a thread, such as shortening the roots of reinforcements in columns and shear walls. In this type of coupler, the end of the armature is placed inside the coupler and the screws are tightened on the armature.

Rebar splices, welding coupler

Considering that AIII armatures are not weldable, this type of couplers are used to connect these armatures to a metal plate. For this purpose, first the armature head is threaded and screwed into the coupler. Then the coupler is welded to the desired metal part.

Rebar splices, position coupler

These types of armatures are designed in the form of male and female armatures so that none of the two armatures can move and are located in two separate parts. The male part has an internal thread and a parallel external thread. The female part also has an internal thread and the locking nut is used to secure the connection.

4- end-bearing splice of rebars

End-bearing splice is implemented by placing the two ends of the compression bars together. The support splice is allowed only for pressure bars with a diameter of 25 mm and more.

In this type of splice, the end surfaces of the rebars should be completely cut and the contact between the two ends should be as complete as possible. The angle of the end surface of each rebar should not deviate more than 1.5 degrees from the surface perpendicular to the axis of the rebar.

This type of splice is allowed only in parts that have a closed transverse or a spiral stirrup.

Foundation

Target

Foundations provide the stability of the structure from the ground level:

- Distributing the weight of the structure over a large area to avoid overloading the underlying soil (possibly causing uneven settlement).
- Anchoring the structure against natural forces such as earthquake, flood, drought, frost, tornado and wind.
- To create a smooth surface for construction.
- Anchoring the structure deep into the ground, increasing its stability and preventing overload.
- To prevent lateral movements of the supported structure (in some cases).

Requirements of a good foundation

The design and construction of a foundation with good performance must have some basic requirements:

- The design and construction of the foundation is done in such a way that it can withstand the dead bodies and loads brought to the soil. This transfer should be done without creating any settlement that could cause stability problems for the structure.
- Differential settlements can be avoided by having a rigid foundation for the foundation. These issues are more pronounced in areas where superimposed loads are not uniform in nature.
- Based on the soil and area, it is recommended to have a deeper foundation to protect it from any damage or discomfort. These are mainly caused by the problem of shrinkage and swelling caused by temperature changes.
- The selected foundation location must be an area that will not be affected by future works or factors.

Types of foundations:

Historical types

Buildings and structures have a long history of being built with wood in contact with the ground. Post in earth construction may technically have no foundation. Wooden piles were used in soft or wet ground even under stone or masonry walls. In marine and bridge construction, the intersection of wood or metal beams in concrete is called grillage.

Counterposts

Perhaps the simplest foundation is the buttress, a stone that both spreads the weight on the ground and lifts the timber off the ground. Stedel stones are a special type of counterstone.

Stone foundations

Dry stones and stones cast in mortar for foundation construction are common in many parts of the world. Dry stone foundations may be painted with mortar after construction. Sometimes the upper and

visible part of the stone is made of cut stones. In addition to using mortar, stones can also be placed in gabions.

Rubble foundations

A rubble foundation is a shallow trench filled with rubble or rock. These foundations extend below the frost line and may have a drain pipe that helps drain groundwater. They are suitable for soils with a capacity greater than 10 tons per square meter (2000 pounds per square foot).

Modern types

Shallow foundations

Shallow foundations are also called wide column footing or open column footing. The word open refers to the fact that the foundations are made by first excavating the entire ground to the foot of the column and then building the foot of the column; are made.

During the early stages of the work, the entire foot of the column is visible to the eye; And that's why it is called open column foot. The idea is that each foot of the column takes a concentrated load (pressure) from each column and spreads it over a wide area; So that the actual weight on the soil does not exceed the safe bearing capacity of the soil.

In cold climates, shallow foundations must be protected from freezing. This is because the water in the soil throughout the foundation can freeze and bulk; thereby causing damage to the foundation.



Image of isolated shallow foundation

Types of shallow foundations

The following are types of shallow foundations.

1. Isolated foundation

This is the most common and simplest type of shallow foundation, as it is the most economical. An isolated foundation consists of a foundation that rests directly on the component foundation. In general, each sector has its own foundation. They transfer loads directly from the column to the soil. It may be rectangular, square or round. It can include both reinforced and non-reinforced materials. However, for unreinforced foundations, the foundation riser must be more prominent to provide critical load distribution. They should probably be used when it is beyond doubt that no differential settlement will occur under the entire structure.

2. Wall foundation or strip foundation

Wall foundation is also known as foundation foundation. This type is used to distribute the loads of structural or non-structural load-bearing walls on the ground in such a way that it does not exceed the load bearing limit of the soil. It runs along

the direction of the wall. The width of the wall foundation is usually 2-3 times the width of the wall.

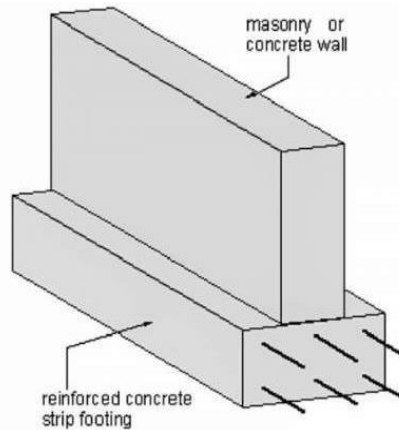

Wall or strip foundation

The wall foundation is a strip of foundation slab along the length of the wall. Stone, brick, reinforced concrete, etc. are used to build the foundation of the walls.

3. Combined foundation

Combination foundation is very similar to isolation foundation. When the columns of the structure are carefully placed or the bearing capacity of the soil is low and their foundations are placed on top of each other, a composite foundation is provided. It is basically a combination of different foundations that use the properties of different balances in a single foundation depending on the necessity of the structure.

4. Belt foundation

Belt foundations are similar to combination foundations. The reasons for considering or choosing a strap foundation are the same as for composite ones.

In strap foundations, the foundation under the columns is made separately and connected by a strap beam. Generally, when the edge of the foundation cannot extend beyond the property line,

the outer foundation is connected to the inner foundation by a tie beam.



Belt foundations

5. Raft or wicker foundation

Raft or straw foundations are used where other shallow foundations or piles are not suitable. It is also recommended that the load of the structure should be distributed over a wide area or that the structure is constantly exposed to impact or shaking in situations where the bearing capacity of the soil is insufficient.

The raft foundation consists of a reinforced concrete slab or a T-beam slab placed over the entire area of the structure. In this type, the entire basement floor slab acts as a foundation. The overall load of the structure is spread evenly throughout the entire area of the structure. It is called a boat because in this case, the building looks like a ship floating on a sea of dirt.



raft foundation

Deep foundations

It is used to transfer the load of a structure through the upper weak layer of surface soil to the stronger layer of the subsoil below. There are several types of deep foundations, including impact piles, driven shafts, caissons, screw piles, geopiles, and earth-reinforced columns.

Designing:

Foundations are designed to have an appropriate load capacity depending on the type of subsoil/rock supporting the foundation by a geotechnical engineer, and the foundation itself may be structurally designed by a structural engineer. The primary design concerns are seating and carrying capacity. When considering settlement, total settlement and differential settlement are usually considered.

Types of deep foundations

The following are types of deep foundations.

1. Pile foundation

A pile is a common type of deep foundation. They are used to reduce costs and when, due to soil conditions, it is desirable to transfer loads to soil layers that are beyond the reach of shallow foundations.

Below are the types of candle foundations.

• Based on performance or use:

1. Sheet pile
2. Load bearing piles
3. The end of the pile bearing
4. Friction piles
5. Soil compactor piles

Based on materials and construction method:

1. Timber piles
2. Concrete piles
3. Metal piles
4. Composite piles

A pile is a thin member with a small cross-section compared to its length. When the bearing capacity of the soil near the surface is relatively low, it is used to transfer foundation loads to deeper soil or rock layers. The pile transfers the load either through skin friction or bearings. Also, piles are used to resist the structures against rising and creating stability of the structure against lateral forces and overturning.

Pier foundation:

A pier is an underground structure that carries a heavier load that cannot be carried by shallow foundations. It is usually shallower than the masses. Foundations are usually used in multi-story structures. Since the foundation area is determined by the design strategy for regular settlement, single foundation load testing is omitted. Along these lines, it is increasingly recognized in harsh conditions.

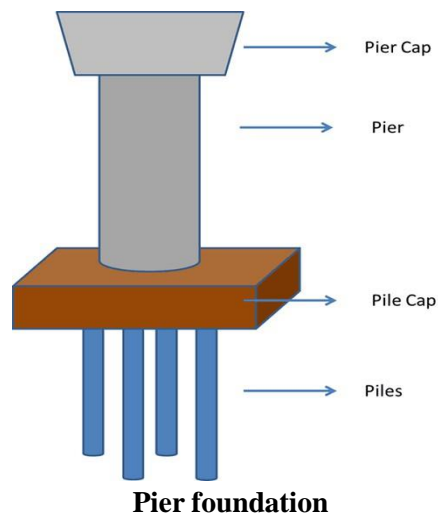

3. Caisson foundation

A caisson foundation is a waterproof retaining structure that is used as a bridge foundation, dam construction, etc. It is generally used in structures that require foundations under rivers or similar bodies of water. The reason for choosing a caisson is that it can be floated to the desired location and then sunk into place.



Caisson foundation

Concrete building implementation steps

Destruction

In general, demolition means destroying, but in technical and engineering science, any action that causes the separation of materials, equipment, installations, members and structural and non-structural components, etc. from the building or dismantling all or part of the building is called demolition. will be

The purpose of demolition is generally to remove, renovate, repair or rebuild the structure, which is done using various tools and equipment. The reason for this is the end of the useful life of the structure and the emergence of various risks, including the building not being safe for life. We also try to separate usable materials from waste and reuse them.

Excavation

Excavation is the process of moving earth, rock or other materials with tools, equipment or explosives. This includes embankment, trench, shaft wall, tunneling and underground. Excavation has a number of important applications including exploration, environmental restoration, mining and construction. Meanwhile, construction is one of the most common applications of excavation. Excavation is used in construction to create foundations for buildings, reservoirs and roads.

How does the excavation process work?



Before excavation and heavy earthmoving operations begin, the site must be carefully surveyed to ensure that the natural habitat and

surrounding artifacts are stable during the excavation process. In the next step, maps are made for the size and depth of the site, and excavation contractors draw maps from them so that the boundaries of the excavation site are clearly defined. After completing these two important steps, digging can begin.

The whole drilling process includes:

- Determining corner criteria
- Mapping terrain and high levels
- Excavation to the permitted depth
- Dressing loose soil
- Construction of water wells and connected trenches
- Create building boundaries
- Construction of protection and drainage strips

How to choose a dredging team?

Construction excavation requires experience, skill and careful attention to detail because it deals with large structures and creates the foundation and foundation of the entire project. Heavy industry contractors use advanced techniques, tools and heavy machinery to make sure the job is done right. Hiring heavy industrial contractors to complete large excavation projects will bring the best results.

Excavation work steps at the construction site

The work procedure for excavation at the construction site includes understanding the centerline and excavation plans, setting the plan on the ground, excavating soil and removing excess soil. Qualitative checks such as recording the ground level and marking reference points should be done.

Excavation is the process of moving earth, rock or other materials with tools, equipment or explosives. It also includes trench, wall shaft, tunneling and underground. The primary activity is the construction project.

Maps required for excavation

1. Draw the central line or grid line

Grid line maps show grids marked with numbers and letters whose measurements are shown for site marking reference. These grid lines are so level that the line falls on the excavation and foundation.

2. Excavation plan

Excavation map shows the length, width and depth of excavation. The dredging line is marked as a dotted line.

Scope of work for excavation

The main works done before, during and after excavation are as follows:

Setting criteria outside the corner

Survey of land surfaces

Survey for high levels

Excavation to the permitted depth

Dressing loose soil

Makeup up to the cutting surface

Construction of water wells and connected trenches

Marking building boundaries

Construction of protection bands and drains

Digging method

The first and primary step in digging a hole is taking the foundation to the extent of the soil and cleaning the construction site from bushes, weeds and unwanted plants.

Setting up or tracing the ground is the process of placing the trench lines and center lines etc. on the ground before excavation begins.

A maximum of 4 and a minimum of 2 standards are specified in the corner to measure the level. These criteria are specified on permanent structures such as roads or trees.

Traces are marked with lime powder.

By referencing maps and standards, the depth of excavation is fixed.

Excavation is done by hand or machine according to availability.

Excavated soil must either be removed from the site or stored around the excavation pit. A minimum distance of 1 meter between the excess soil storage and the pit should be observed so that the soil is not swept into the pits due to rainfall or other forces.

Dressing of excavated pits should be done according to the plans.

If the site is located in a loose soil area, appropriate chipping should be done to maintain the loose soil.

If necessary, the construction of water wells and trenches connected to each other will be provided.

For safety reasons, all sides of the building must be sealed.

Remove excess soil

Estimate excavated material for fill, landscaping, road preparation, etc. As much as possible, try to excavate and fill at the same time to avoid double displacement. Select and stack the required materials in a place that does not interfere with other construction activities. Excess or unwanted material should be removed and disposed of immediately.

Excavation of surface soil

This involves removing the bare layer from the ground surface, including any vegetation or decaying material that can make the soil compactable and therefore unsuitable for carrying structural loads. The depth varies from site to site, but is usually in the range of 150-300 mm.

Excavation of land

This involves removing the layer of soil directly below the topsoil. The removed material (referred to as "tailings") is often stored and used to build embankments and foundations.

Stone excavation

It is the removal of material that cannot be excavated without using special excavating methods such as excavating (by hand or heavy machinery) or blasting with explosives.

Sludge excavation

This is the removal of excessively wet material and soil that is unsuitable for storage.

Unclassified excavation

This removal is a combination of the above materials, such as where it is difficult to distinguish between the materials you encounter.

Excavation can also be classified according to the purpose of the work:

Trench excavation

A trench is an excavation whose length is much greater than its depth. Shallow trenches are usually less than 6 meters deep and deep trenches are considered more than 6 meters. Trenching, or foundation excavation, is commonly used to form strip foundations, burying services such as pipes, etc. The choice of technique and plant for digging, supporting and filling the trench depends on factors such as: the purpose of the trench, the ground conditions, the location of the trench, the number of obstacles, etc.

Excavation of the basement

A basement is a part of a building that is partially or completely below ground level.

Digging the road

This usually involves removing topsoil and cutting and filling to create the required surfaces.

Bridge excavation

This usually involves the removal of the bridge's foundation and support materials. The work can be divided into wet, dry and stone excavation. Underwater excavations may require special methods of excavation and blasting.

Dredging

Dredging is the process of excavating and removing sediments and debris from below the water surface, usually from the bottom of lakes, rivers, harbors, etc.

Excessive pitting

Over-excavation is excavation that exceeds the depth required to form an underground structure due to the presence of unsuitable material that must be removed. The excavation may then need to be backfilled to create the required levels.

How are excavations supported?

Materials have different stability characteristics during excavation operations. A material's "angle of repose" describes the steepest angle at which it remains stable without support. The exact angle of repose depends on the presence of groundwater, but some common angles are:

Drained clay: 45 degrees.

Wet clay: 16 degrees.

Dry sand: 40 degrees.

Wet sand: 22 degrees.

Temporary support may be required where there is a risk of trench collapse. The type and amount of temporary support needed depends on a variety of factors, including:

Stability and angle of repose under soil

Excavation proximity to vehicles, services and buildings

Static level

Subsoil types

Excavation depth

The length of time that excavation remains open

Time of year and weather conditions

The types of support that can be used are:

Wooden supports: usually used for low risk, narrow trenches, shafts or headers.

Trench boxes: can be placed in pre-dug trenches in low risk positions.

Trench Sheets: Can be stacked or connected and used for continuous support of deeper trenches.

Ground anchors and stone bolts

Caissons

Cofferdams

Implementation of lean concrete

After the completion of excavation and ensuring the stability and safety of the pit, we enter a new operational phase called foundation construction. Carrying out different parts of this operation is also very important. The first step in order to implement the foundation is the implementation of lean concrete. Lean concrete is actually a concrete with a low cement grade (between 100 and 150 kg of cement per cubic meter) that is used to prepare the substrate. The pit is executed for reinforcement and subsequent steps.

Concrete should normally be about 5 to 10 cm thick, and there is no engineering justification for more than that. This concrete does not have a structural role and does not need high strength in order to prevent possible stresses and is mostly used as a cover layer to prevent the absorption of the original concrete sap by the soil. It is also necessary to clean the place of concreting from any pollution, soil, lumps, roots of plants and plants, and moisten the foundation floor with water so that the soil does not absorb the concrete juice before applying the concrete.



Implementation of lean concrete

Substrate preparation and concrete execution

Conventional note: Considering that the surface of the foundation floor always has some misalignment and this problem may not be effective in the height of the concrete, it is assumed that the operation bed (final leveling of the excavation) should be carried out more carefully and also during the contract. In the contract with contractors and executors of concreting, it is necessary to consider the height of concrete except with a fluctuation of 5% positive and negative, so that the possibility of any possible claim regarding this issue from the contractors is solidified. As usual, the method of payment for concrete execution is in the form of square meters, except in the contracts.

Implement the map

The operation of putting a map on the ground is exactly the opposite of the operation of preparing a map or surveying the land. The meaning of implementing the map on the ground is actually the same as implementing the foundation plan of the building.

The plan presented in the next post will be used as an example to explain how to implement the map on the ground. In this example, it is assumed that the only known extension is the 16-meter street marking.

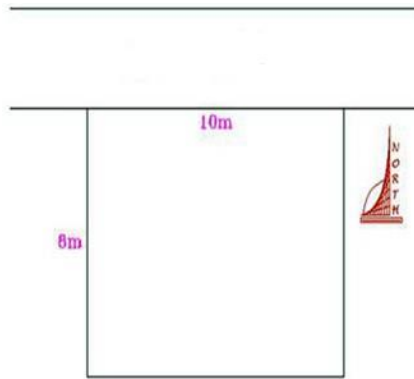

The plan to explain how to implement the map on the ground

As mentioned in the figure (the example figure used to explain the method of implementing the building plan), it is assumed that the table drawn next to the street has a known length of 16 meters.

Implement the known line or extension:

- 1- A little far from the corner of the ground, (for example, about one meter away), a nail (wooden or metal) called off nail is hammered into the ground.
- 2- In the corner of the other side of the ground, another off nail is driven with the same approximate distance.
- 3- These two points are connected to each other using the work string.

Considering that the off nails and the created extension will be used in implementing the foundation plan, axing the columns, facade construction, etc., therefore it is very important to maintain the known extension created until the end of the work.

In order to maintain this extension, it is necessary to keep the two knocked-off nails in place until the end of the project, so that if necessary, the known extension can be re-created using a stringer at any time. For this reason, off nails are executed at a distance of about 1 meter from the corner of the field.

The above steps are shown in the figure below.

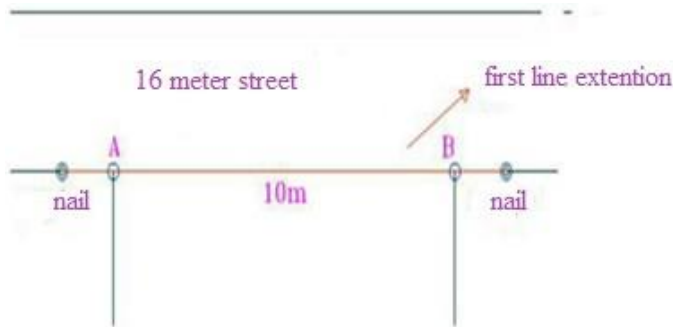

Draw a known line

To start the next extension from point B, one meter away, we knock a nail off and tie the stringer to it and continue to point C.

We measure the first extension (AB) and the second extension (BC) approximately and visually.

Then, one meter away from point C, another nail is hammered, and then we use the Pythagorean theorem (or so-called workshop method: method 3, 4, 5) at point B to connect these two extensions.

Method 3, 4, 5: First, we separate the number 4 meters from point B in one of the extensions (in this example along the BC extension) and in the other extension (in this example along the AB extension) we separate the number 3 and with a pencil or We mark its color on the string. We connect these two points with a meter and by moving the length of BC, we place the chord of the triangle on 5 meters, and in this way, according to the Pythagorean theorem, the angle ABC will be gonius.

Note: It should be noted that the length of AB is a known length and therefore the length of BC must be moved to make the angle ABC right.

To implement the third extension (CD), tie the stringer to the off nail next to point C and roughly and by eye gounia until we reach point D.

Then, one meter away from point D, another nail is hammered and we use the Pythagorean theorem at point C to connect two lengths (BC) and (CD).

Now we connect point D to point A with a string.

To control the work of implementing the extensions, the diameters of the implemented rectangles are measured and if the diameters are equal, the implementation of the map is acceptable and correct.

Note: Usually, in the continuation of the work, plaster is poured on the stretches marked with a stringer. For this purpose, care should be taken to pour plaster exactly on the string and as thinly as possible.

Note: The stringer should be performed at a short distance from the ground and completely stretched, and no part of it should be in contact with the ground.

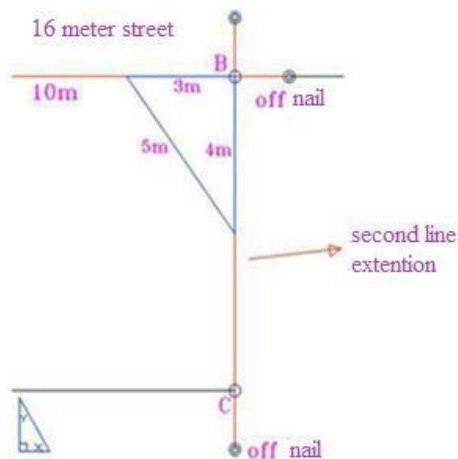

Concatenation of two lengths AB and BC using the Pythagorean theorem

Foundation reinforcement

Concrete foundation construction instructions guarantee the strength, durability and longevity of foundation structures. As a result, concrete foundations are built correctly and according to standards and requirements.

Construction guidelines for concrete foundations can be obtained from building codes such as the American Concrete Institute and

Indian Standards and to some extent from engineering experience and judgment.

Preparing the base for the foundation

Concrete foundations should be built on firm, undisturbed soil, engineered fill, or coarse gravel. Standing water, mud, frozen ground and other debris must be removed. If the underlying soil is of low quality, it should be removed and a layer of sand with a thickness of 100 mm should be prepared. Surface tolerances for prepared subgrade should not exceed 5 mm, -15 mm.

If the concrete is not mixed with water, up to 25 mm of standing water may be displaced. Removal of unsuitable materials under the designed footing is required to create a sound subgrade for the footing. Overburden can be filled with engineered fill or concrete.

arrangement of bars

Reinforcement is required in the foundation to ensure the continuity of the structure. This is especially important in cases where the ground is bad or the building may be subjected to earthquake forces.

Metal reinforcements in the foundation include reinforcements that are placed longitudinally, transversely or both in the direction of the foundation.

Longitudinal reinforcements are sometimes used to bridge soft spots and small trenches or to increase strength in narrow excavations.

Transverse foundation reinforcement is usually not required unless the bearing capacity of the soil is poor or the load on the walls is high.

Transverse or longitudinal reinforcing bars should be placed near the center of the thickness of the foundation with a minimum cover of 75 mm to the bottom and sides.

Foundation rebars can be installed on posts, building bricks or other supports.

The minimum distance between individual bars should be 150 mm.

After installing the rebar, the following items must be visually checked and confirmed.

The minimum rebar size is 16 mm.

The tolerance of the position of the reinforcing bars should not be more than ± 6 mm.

Where the reinforcement cannot be installed in one length to meet the reinforcement requirements, the reinforcing bars shall be lapped to develop the full tensile capacity of the bars throughout the connection.

According to ACI-318, a minimum lap length of 40 times the rebar diameter is required for connections in rebar.

Spacing between bonded or bonded rebars shall not exceed eight times the diameter of the reinforcing bar or 6 inches, whichever is less.

Concrete for foundation

Concrete strength should not be less than 17 MPa. If the foundation is exposed to aggressive environmental conditions and earthquake forces, this amount should be increased.

The concrete cover for the foundation in direct contact with the soil should be 75 mm.

Placement of concrete for foundations can be by any conventional method including direct chute, wheelbarrow, crane, pump or conveyor.

Remove the mold

The mold separation time is 12 hours. Formwork should not be removed earlier than 12 hours after completion of concrete finishing work.

Correction of surface defects

After removal of formwork and completion of curing, each concrete structure should be visually inspected for surface defects. The points to be checked are as follows:

Finished concrete surfaces

Leveling the finished concrete

Levels and alignment of embedded items such as anchor bolts.

Tolerances for levels and alignments

Repairing foundation surface defects

Hack all unhealthy and cracked concrete to a depth of more than 50 mm. In areas where the rebar is exposed, remove the concrete behind the rebar.

For corroded rebar, loose rust scales should be removed by wire brushing. Treat the rebar with an anti-corrosion primer.

The edges of the feather should be removed along the perimeter of the hacked area using a disc wheel.

Remove loose dirt and dust from the prepared surface using clean water.

Pack clean, hand-washed material into the hacked area and secure with fine wire mesh.

Install the solid grout forms on the prepared surface and secure the formwork with appropriate fasteners.

Using a hand slurry pump, pour clean water through the inlet ports into the mold assembly. Ensure that the prepared surface and aggregates have reached saturated dry surface (SDS) conditions.

Mix the slurry with sufficient water in a drum mixer. Make sure that the slurry reaches a homogeneous consistency while stirring.

Spread the grout mixture through the inlet ports into the mold assembly. The injection should be done from the lowest inlet port. As soon as grout emerges from the adjacent port, lock the first port and grout through the adjacent inlet port. Continue injecting sequentially until the entire mold assembly is filled with grout.

Remove the mold assembly and process using composite bags or wet gunny sacks (burlap).

If necessary, grind the surface to make it even.

Dowel bars

Reinforcement dowel, also called dowel bar, is a type of rebar that transfers the load of a concrete member to its adjacent member. In fact, architects provide the foundation for the continuation of concreting and development of the building by using the reinforcement. Usually, simple metal reinforcements with 250 gauge are used to make the waiting armature and they are covered with stainless steel or epoxy to prevent corrosion.

Dowel or waiting reinforcement refers to rebars that cannot be completely implemented due to the following reasons.

1. Executive and operational problems
2. Limiting the length of rebars produced in the factory

In fact, due to the limited space of the workshop and also due to the operational conditions, it becomes impossible to use the rebar completely and allow the creation and restraint of the rebar.

In addition, because the length limitation in the construction of the armature itself is another reason to use the root armature.

Advantages of not using dowel bars

1. Preventing armature deviation
2. Saving time and expert effort to cut and close the rebar
3. Higher execution speed
4. Reduction of slippage in the rebar on the first floor due to the maximum anchorage at the foot of the column
5. Reduction of rules and regulations regarding Orlab and other design issues

Disadvantages of using continued rebar

1. The possibility of creating a cold seam
2. Implementation conditions may make it impossible to allow such work.

Rules in codes

1. The diameter of the root reinforcements that are placed in the foundation, if they are different from the diameter of the column rebars, and also if the reinforcements are always under pressure and are patched, the length of the patch cover in the column is based on the largest compressive restraint length of the reinforcement with the diameter. The larger and length of the rebar patch is chosen with a smaller diameter. In the same situation, if the rebars are under tension, the length of the patch of the waiting rebars or the root with the column rebars at the foot of the column is determined based on the length of the patch corresponding to the larger diameter rebar.
2. The regulation states that cover patches are not allowed for rebars of size 36 and above, except for rebars of size more than 36 to transmit compressive force.

The main specifications of the dowel bars

Dowel reinforcement or waiting usually in sizes 1. 25 to 1. 5 inches and 18 inches long. To achieve the best possible result, these rebars are placed in the concrete and structure at a distance of 12 inches from each other. Of course, this distance can vary depending on the type of building.

The length and diameter of the slab root reinforcement

According to the ACI 302.1R standard, the length and diameter of the waiting reinforcements used in concrete slabs are directly dependent on their thickness. The table below shows the length, diameter and thickness of the slab root reinforcement:

If the thickness of the slab is more, you can use the root reinforcement with a diameter (38 mm) and a longer length (460 mm). You should

know that long length does not affect the better transmission of compressive and tensile loads; But a very short

length can increase the stress concentration on the joint surface and thus cause concrete failure.

Application of dowel reinforcement

In general, dowel reinforcement is used to connect members and different sections between the layers of a member. Of course, it also has other key uses, which we will describe below in the form of titles:

Dowel reinforcement connects the column to the beam in the building.

Dowel reinforcement will also be used to connect the slab to the column.

Beam to beam connection is also done using this type of rebar.

You can also connect the root of the staircase to the slab by using the reinforcement so that it has the necessary resistance against vibration.

Dowel reinforcement is also used to connect the slab to the slab.

Also, the last use of this rebar is to connect the column to the foundation and the main foundation of the building.

dowel reinforcement in the foundation of buildings

These rebars can show great power to withstand force and pressure. If you think that the reinforcements of the structure do not have the necessary power to withstand the pressure and force of the column due to the high height of the building, you can use the root or waiting reinforcement. This rebar usually continues until the required level of bending reinforcement in the building and then it will be bent. On the other hand, one of the most important parts that can increase the strength in residential and commercial concrete buildings is the foundation part. So, make a reasonable investment on this part as much as you can to avoid future financial and life losses.

Application of dowel reinforcement in bascule foundation

One of the widespread applications of reinforcement is expected to be used to strengthen the connection between columns or walls that are placed on bascule foundations. For this purpose, the root reinforcements are placed in the foundation before concreting and then they are patched to the longitudinal reinforcement of the column or wall.

Application of dowel bar in wide foundation

Dowel reinforcement is also used in wide foundations. The way of using reinforcements in this case is similar to bascule foundation. For this purpose, the reinforcement continues to the level of the bending bars of the foundation and their lower ends are bent at a 90 degree angle. The result of this work is to fasten the root reinforcement to the upper and lower rows of foundation bars to prevent them from moving during concreting.

How to use the dowel bar in the slab

Concrete slab is actually an important member of buildings that is prepared and designed in a prefabricated or on-site form. The main component of any building slab is rebar and concrete. In fact, root reinforcement is used to connect different parts of the slab or different parts to the slab. In fact, the slab causes more efficient and resistant flooring of residential and commercial buildings and the paving of vehicle paths (overpasses and underpasses).

How to place the dowel bar in the slab

The placement of the waiting reinforcement in the slab directly affects the load transfer, cracking and spalling of the joint area. So, when installing the reinforcements, you must be careful enough and do this parallel to the central axis of the concrete member.

In fact, the installation direction of the root reinforcement has nothing to do with the slope and orientation of the seams. In addition, we must mention that the equality of the length of the rebars in the two parts adjacent to the concrete slab will improve the work result.

The steps of connecting the column rebar network to the column dowel

After implementing the foundation and installing the waiting bars, if we want to place the column bars next to the waiting bars, the column should be deviated from its axis by the thickness of the waiting bars. But it is better to create a small curve in the column armatures so that the column is right on its axis and does not have the slightest deviation.

Curvature calculation:

This curvature should be the same as the diameter of the column rebar, and if it is small and light, we will fix it in the ground with the reinforcement wire.

Then, by supporting the columns, we turn it into a network and after pouring the foundation concrete, we connect the already prepared column reinforcement cage to the waiting reinforcements. This should be done at least 3-4 days after pouring the foundation. Because otherwise, because the concrete of the foundation has not hardened yet, due to the anchoring of the column reinforcements, the waiting bars will move and the foundation will collapse.

After concreting the column reinforcements, to stabilize the position of each column, its dimensions are determined by wooden beams at the foot of the column. Or they draw the dimensions of the column with a colored thread to place the stencil on it. It should be noted that to stabilize the dimensions of the column, it should never be done by pouring at its foot. The cross section of most columns in normal buildings is square or rectangular and rarely circular or polygonal. In any case, the cross-section width of the column should not be less than 20 cm, and its cross-section should not be less than 600 cm.

The longitudinal and transverse reinforcements of the columns must be woven together in such a way that there is no risk of the reinforcements moving and moving away from each other during transportation, laying and concreting.

The minimum diameter of longitudinal reinforcements is 14 mm and the minimum number of longitudinal reinforcements is 4 in square and rectangular sections, 6 in circular sections and the number of sides in polygonal sections.

Foundation shuttering

Foundation molds are made of recycled and recyclable plastic and allow the creation of voids under concrete foundations of new or renovated buildings in the civil, commercial and industrial sector. The voids created by the foundation forms provide many advantages such as the passage of piping and its expansion and isolation of the foundation from direct contact with the natural ground, and can also be used in the construction of sidewalks, squares, and streets. .

All formwork materials must be selected and installed to achieve the required concrete surface finish.

The joints between the formwork plates must be sufficiently sealed to prevent grout leakage during casting and concrete compaction.

Formwork should be measured prior to pouring concrete to confirm locations, alignment and top of concrete surfaces.

Where the formwork extends above the concrete surface, the top of the concrete surface shall be clearly marked on the formwork with a nail and/or chalk line.

The foundation form must be selected and arranged in such a way that it has sufficient strength, hardness and stability to maintain the weight of wet concrete during placement.

The mold should be stiffened if necessary to ensure that it does not deform significantly during concrete casting.



Foundation shuttering

The two-way ventilation created in the middle and peripheral beams should be done with pipes with a diameter of 10 cm at a distance of 2.5 to 3 meters from each other. This system creates aeration in the foundation to remove both radon gas (a cancer-causing gas) and any upward moisture, if present. It also improves the comfort of the environment above the foundation, because the floor is drier and has a constant temperature that is not colder.

Foundation forms can be easily installed and moved on site, and their advantage is that they reduce excavation costs compared to the traditional system, limit the use of sand, and avoid intensive exploitation of mines.

Foundation formwork is a modular formwork designed to support concrete slabs and create voids that have several added benefits. The structure consists of concrete slabs and columns, which, when built, allow it to withstand exceptional additional loads.

Thanks to the coupling system of the foundation molds, it provides the stability of the parts during the installation and casting of concrete. Especially the foundation molds that are 5 or 9 cm (without concrete casting) can withstand loads higher than 10,000 kg/m², because the supporting foundations have a stepped arrangement and are smooth, round and circular. Individual pieces can be cut to size using a wheel/disc cutter without compromising its mechanical strength.

The free space under the foundation forms also allows the passage of pipes for electric, water, telephone, heating, etc. cables. This also allows for easy inspection at a later date.

Types of formatting in foundation shuttering

metal mold

What are known as metal molding components are different components for concrete molding. These components can be different in different projects. Examples of metal mold components are: cast iron screw, case washer, ball belt, coarse grain metal longitudinal clamp, two screw jack, etc.

brick mold

This type of mold is used around the foundation and remains in the desired location after the concrete is preserved and is considered a permanent mold. To prevent the concrete from being compressed by the bricks, a layer of nylon sheet is required before the concrete. Finish the installation on the wall, otherwise the bricks must be completely sprayed.

In this type of formatting, the limits of axes and structural forms must be specified by the surveyor. In order to avoid the smallest error in doing this type of molding, it is recommended to nail the corners of the axes and stencils and after marking them with thread, paint the edges of the templates. In addition, the surface of the land must have a uniform level, which is done by mapping. When molding bricks, a thin layer of cement must be molded into the inner wall, but otherwise plastic can be used. The back of the brick mold can be filled with soil.

wooden mold

As the name suggests, wooden mold is made of wood. The molds are made large enough to be moved to the desired location. Molding of concrete in these molds requires sufficient care to prevent damage to their edges. Wooden molds are lighter in weight than metal molds, but their resistance to moisture is not high.

concrete mold

What should be considered in concrete forms is the strength of the forms and their proper bracing. To increase the durability of

scaffolding, it is necessary to use longitudinal and transverse belts. Concrete formwork should be designed in such a way that the concrete is prevented from coming out of them. The molds must be cool to run the concrete. If the molding is hot, it will reduce the quality of concrete and change its color. This causes the concrete to lose its shape.

Foundation concreting

Pouring a concrete foundation is a very important step in foundation construction and plays a vital role in the success of a project. For concreting the foundation, proper planning, selection of proper equipment, and proper placement should be adopted to ensure that it conforms to the drawings and specifications.

Planning for the concrete pouring process

Proper planning is very important as it ensures adequate and consistent supply of concrete. Adequate placement capacity must be ensured to prevent cold joints from forming during concrete pouring.

Molds

Before concreting begins, forms should be protected from deterioration, weathering, and shrinkage by proper lubrication or effective damping. Form surfaces should be clean and have a uniform texture. When reuse is permitted, molds must be properly lubricated. Finally, it is recommended to apply oils to the mold before placing the armature and other parts.

Reinforced and embedded items

At the time of concrete pouring, the reinforcing steel and embedded items must be clean and free of mud, oil and other substances that can negatively affect the adhesion capacity of the steel.

Size, length, connections and position of reinforcements and adequate concrete cover should be checked. Bars and embedded items must be securely held and supports must be adequate to carry the expected loads before and during concreting.

Choosing concrete pouring equipment

When choosing concreting equipment, consider the equipment's ability to place concrete in the correct location economically without compromising its quality.

The choice of equipment is influenced by the method of concrete production. Certain types of equipment, such as buckets, hoppers, and carts, are suitable for batch production. While other equipment, such as conveyor belts and pumps, are more suitable for continuous production.

Concreting

Before concreting begins, care must be taken to prevent separation of the concrete flow due to free fall on bars, spacers, rebar or other embedded materials. Concrete should be placed at or near the final position because it tends to separate when it has to flow laterally into place.

Density of concrete

Internal vibration is the most effective method of concrete consolidation for most applications. The vibrator should be inserted and removed vertically to quickly penetrate the layer and slowly withdrawn to remove trapped air.

Re-vibration of the concrete can be done until the working vibrator sinks into the concrete under its own weight. Re-vibration of concrete improves compressive strength and adhesion.

Joint preparation

Construction joints are observed wherever concreting is stopped or delayed and the newly poured concrete does not integrate with the previous concrete.

Horizontal construction joints are formed at the levels between the risers, while vertical joints occur where the length of the structure is such that it is not possible to place the entire length in one continuous operation.

The surfaces of all construction joints shall be cleaned and properly prepared to ensure adequate adhesion with the concrete on or adjacent to them.

Finishing the concrete surface

After the concrete is compacted, the first staining, floatation and troweling operations must be done in such a way that the concrete can be worked and manipulated to achieve the desired result.

Implementation of the column

A column in architecture and structural engineering is a structural element that transfers the weight of the upper structure to other structural elements below through compression. In other words, a column is a compression member. The term column is used specifically for a large round support (column shaft) with a capital and base made of stone. A small wooden or metal support is usually called a post.



Columns of the Parliament House in Helsinki, Finland

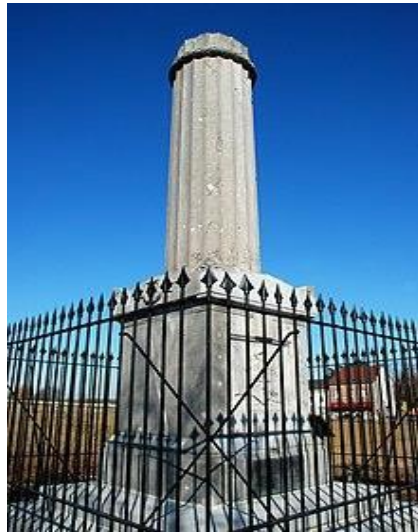

Gordon's Monument at Waterloo column

Structure

Early columns were made of stone, some of one stone. The monolithic columns are one of the heaviest stones used in architecture. Other stone columns are created from several sections of stone, mortared or dried together. In many classical sites, truncated columns were carved with a central hole or depression so that they could be joined together using stone or metal pins.

There are flutes and fillets that rise from the shafts of the columns. The flute is a part of the column that is sunken in the shape of a semicircle. The column fillet is the part that is located between each of the flutes of the ionic order columns. The width of the flute in all conical columns changes as the shaft rises and remains the same in all non-conical columns. This is done for columns to add visual appeal to them.

Naming

Most classical columns rise from a plinth or plinth that rests on a stylobate or plinth, except for columns of the Doric order, which

usually rest directly on the stylobate. The base may consist of several elements, starting with a wide, square slab called a plinth.

At the top of the shaft is a capital on which the roof or other architectural elements are placed. In the case of Doric columns, the capital usually consists of a narrow round cushion or echinus supporting a square board known as an abacus or abacus. Ionic capitals have a pair of scrolls, while Corinthian capitals are decorated with reliefs in the form of acanthus leaves. Each of the capital types can be associated with the same basic formatting. In the case of standing columns, the decorative elements at the top of the shaft are known as finials.

Modern columns may be constructed of steel, cast or precast concrete, or brick, with or without architectural cladding or cladding. Used to support an arch, a pillar or base is the highest member of a column. The lower part of the arch, called the spring, rests on the stone.

Balance, instability and loads

As the axial load on a perfectly straight slender column with elastic material properties increases, this ideal column passes through three states: stable equilibrium, neutral equilibrium, and instability. If the lateral force between the two ends of the column creates a small lateral deflection that disappears and returns to its straight state when the lateral force of the column is removed, the straight column under load is in stable equilibrium. If the load on the column is gradually increased, a situation is reached in which the straight state of equilibrium becomes a neutral state, creating a small deflection lateral force that does not disappear, and the column remains slightly bent in this state. The lateral force is eliminated. Buckling load instability occurs when a slight increase in column load causes uncontrollable growing lateral deflections leading to complete collapse.

Extensions

When a column is too long to be built or transported in one piece, it must be extended or spliced at the construction site. A reinforced concrete column is extended by projecting steel reinforcing bars a few inches or feet above the top of the concrete, then placing the next level of reinforcing bars to overlap, and pouring the next level

of concrete. A steel column is extended by welding or bolting splice plates to flanges and webs or column walls to provide a few inches or feet of load transfer from the top to the bottom of the column. A wooden column is usually connected using a steel pipe or sheet metal wrapped over two wooden sections.

bases

A column that transfers the load to the foundation must have a means of transferring the load without overstressing the foundation material. Reinforced concrete and masonry columns are generally built directly on concrete foundations. When placed on a concrete footing, a steel column must have a base plate to spread the load over a larger area, thereby reducing the bearing pressure. The base plate is a thick, rectangular steel plate that is usually welded to the bottom end of the column.

Steps to execution a column

First step: preparing the dowels

The column that is supposed to be reinforced is either at the foundation level or in the lower floor column. To connect the column to the foundation, a number of rebars are placed inside the foundation as the rebars to which the column rebars must be connected. These rebars are called the dowel of the column inside the foundation. In order for the column of the upper floor to be connected to the column of the lower floor, the bars of the column of the lower floor are stretched to the height of the floor of the upper floor, and then the bars of the column. It is connected to them. Before reinforcing the column, the waiting bars must be cleaned of any contamination. The cleaning of rebars includes decontamination with all kinds of oils as well as sprayed concrete during concreting of the foundation or floor.

The second step: strengthening the column

According to the contents of the drawings, we put the main rebars together and tie them together with spacers at certain intervals. For

this purpose, we place two arches on the ground with a certain distance so that the top and bottom of the main bars are placed on it.

Next, we pass the khamuts around the main bars and after dividing the distance between the khamuts, we tie them together with wire. If considering the implementation of the next floor, the cut length of the column bars should be such that after the implementation of each roof, the root bar or waiting for the next floor is provided.

The third step: establishing the reinforcement column

We keep the woven column vertical and tie the longitudinal rods to the root rods with wire. In cases where the woven column is heavy, lifting and placing the rebars is done by a crane.

The fourth step: shuttering

At this stage, it is time to shuttering of column. Wooden and metal molds are usually used in the shuttering of columns.

The fifth stage: concreting and its compaction

After placing and securing the woven rebars and completing the formwork, concreting begins. In general, according to the recommendations of the concrete regulation, the height of concreting should not be more than 0.9 to 1.2 meters because pouring concrete from a high height leads to the separation of grains. It is done in 4 or 3 steps. If the concrete is poured and compacted in several stages, the time interval of the concreting stages should be carefully limited so that the previous concrete has a paste state and a complete connection between the different layers of concreting is established. In tall columns, hard concrete (concrete with low slump) and a concrete pump should be used to prevent excessive watering of concrete.

Column reinforcing

The column is one of the vertical members of the structure, which is mainly affected by axial pressure.

From an economic point of view, it is better if the majority of the load is carried by the concrete, but since very few members are affected by the pure axial force, and on the other hand, they transfer part of the compressive load to the rebar. In addition to saving the dimensions of concrete columns, steel must be used in concrete

columns, and in general, the task of reinforced concrete columns is to bear axial and sometimes lateral forces and transfer them to a lower level.

The method of placing the muffler in the column armature

To withstand the horizontal component of the force at the top of the bent rebar, a tie should be placed at the highest point of the knee and a similar tie should be tied at the lowest point of the rebar knee so that the column resists any destructive bending stress.

Silencer distances should be less in the holding areas.

These areas in the supports are one-sixth of the height of the column.

Silence intervals are obtained according to calculations.

Any distance obtained from the calculations for silencers, two-thirds of its value is considered for the distance of silencers, which will be implemented in the areas of one-sixth of the supports.

Duties of silence in strengthening the column

To deal with the buckling force and to prevent the protrusion of the longitudinal reinforcements, tight or khamut is used in the columns.

Tights have good resistance to transverse and shear forces.

In cases where the column view is visible, it is necessary to connect the bars of the restraints.

The harness rods are placed by means of tights that are tied at the bottom of the armature rack.

Circular columns

These columns have more strength and load capacity than columns with square and rectangular sections.

When reinforcing the column with a circular section, this is done in such a way that first, to keep the longitudinal reinforcements stable,

3 circular spacers are connected, one at the beginning and the other at the middle and last part. At the end, the spacer is connected to the

longitudinal bars so that the longitudinal bars remain fixed and do not move, and the shape of a circular column is obtained.

After that, he started wrapping the coil around the long bars, and the important thing is to make the coil.

This can be done with cylindrical rollers. This roller is located on a horizontal axis and on two supports.

To rotate the cylindrical roller, a steel handle is placed on one side of the support.

In order to make a rotary muffler, the beginning of the spent rebar is attached to a lower appendage on the roller.

Two people are needed to make a round roller with the help of a cylindrical roller.

In this way, one person pulls the rebar to wrap around the cylindrical roller and the other person rotates the cylindrical roller by the handle.

The above action causes the corresponding rebar to be wrapped around the roller.

This continues until the desired length is reached.

It is worth noting because the armatures of the coil muffler must be pulled in the direction of adjustment while winding around the longitudinal bars.

With the presence of fixed silencers, the longitudinal armatures of the column may be closer together, which makes the diameter of the circle of the column smaller.

Spacer parts to strengthen the column

Pieces of different shapes and materials are used to uniformly cover the concrete on the rebars. The parts must be connected to the rebar or the rebar network at the desired intervals before the concreting operation (after the reinforcement operation and before molding) in order to prevent the displacement and change of the location of the

rebars and the uniform coverage of the concrete. which is called cover, everywhere should be observed in the same way.

When using concrete parts, wiring should be done in such a way that the concrete completely covers the surface of the wire so as not to cause further damage.

The place where the reinforced concrete column and beam meet and how to reinforce it:

Generally, there will be three modes for column and beam intersection.

The beam should be wider than the column.

The column should be wider than the beam.

The width of beams and columns should be the same.

In the connection of the beam with the side column, there may be a situation similar to one of the above conditions. In any case, the intersection of reinforced concrete beam and column should take into account the following conditions. The bottom column reinforcements should continue in their original length without bending to the top of the beam as shown in the opposite figure. For the main bars of each member (column or beam), the specified number of standard bars must be implemented exactly. The details of executive plans should be drawn and executed in a way that increases the speed of action and ease of work (draw a 3D image of the members as much as possible).

Column shuttering

To build a structure with high strength, different steps are done using reinforcing boards and shuttering different parts. One of the important steps in the construction of structures is the shuttering of a column, the implementation of which requires compliance with important principles and points in this field. It should be noted that failure to observe any of the important points in the wooden molding of the column during implementation may lead to irreparable events.

The molds that are going to be used for the wooden molding of the column should have a smooth surface and one hand.

Advantages of shutteing columns with wood

If you have a limited budget for construction, wooden column molding is a great option for you.

If you want to use concrete or metal forms for construction, you will face a big problem called handling and transportation. Metal and concrete molds have a lot of volume and weight and need a lot of time and people to implement.

Therefore, part of the construction process and construction operations will be involved in this matter. Fortunately, wooden column molding will not cause this problem due to its light weight and suitable volume.

In general, if we want to have a comprehensive review of the molding of wooden columns, we can conclude that this molding method is suitable for projects that are done at high speed while being small. The wooden formwork of the column has been examined and tested many times for bearing weight and force. The results of these tests show that this molding method can withstand a very high load weight.

The effect of wooden column shutteing on the structure

One of the great effects of concrete and structural wooden formwork is that despite being implemented in a shorter period of time than other forms in construction and building construction, it can be as stable as metal forms in this short period of time.

In general, wood, when healthy, will have the same strength as metal formwork. Considering that the construction is risky and may collapse over time due to the low quality of every part of the structure's skeleton, engineers and architectural experts always try to use wood that does not have joints or cracks. No moisture in it.

The effect of weather on the quality of column shutteing

Certainly, the climate of the area where the structure is built is very important. One of the issues that should be investigated is the effect of weather on the structure of various types of wood. Most likely,

engineers and experts use the wood around the same area for molding.

For example, if the desired wood is from an oak tree, the quality of oak trees in the area should be checked. Also, the moisture level of the wood, its strength and stability, as well as the absence of corrosion and small insects inside the wood structure should be checked.

How to implement wooden column shutteing

Although the shutteing of wooden columns is much easier than the shutteing of concrete, some things must be observed when using the shutteing of wooden columns. For this purpose, we will explain how to implement the wooden shutteing of the column.

Clean and cover the surface of the mold with oil

One of the important issues before using the wooden column shutteing is to clean it and cover the surface of the mold with oil. The reason for using oil to coat the molding surface is that usually a lot of water is used when making the molding board.

During the various processes of making wooden column molding, there is a possibility of water hitting the surface of the mold. If water is in contact with the mold for a long time, the so-called wood may be destroyed and the concrete poured into it may rot over time.

To prevent this from happening, the surrounding wood is completely oiled. The type of oil used to coat the wooden mold is very important. This oil is a special substance that is produced in the industry and can cover all the seams and cracks and prevent water from coming into contact with the materials inside the wood.

Another advantage of coating the wooden column formwork with oil is that the concrete is easily removed from the formwork without being attached to different parts of the formwork.

Hammering a nail on the mold

This is a suitable method to check the structure and strength of the wood used for molding the column. For this purpose, after completely covering the surface of the mold with oil and before

pouring concrete into the mold, a large number of nails are hammered into the surface of the wood. These nails can increase the strength and resistance of wood and determine its structure and quality.

Characteristics of wood used in molding concrete columns

The wood used in molding the wooden column should be healthy, smooth and resinous.

Smooth wood without cracks should be used for column molding bases.

The wood used in the molding of the wooden column must be strong enough to separate the forces caused by the vibration of the concrete without the slightest damage to the concrete.

All kinds of wooden molds

Wood molding is divided into several different categories, which we will explain and define each in the rest of this Medhat Wood article.

Molding raw wood

In raw wood molding, simple logs are used to mold wooden columns. This type of column molding will not have a smooth surface after the concrete structure hardens because it is not grated.

Grated wooden molding

In wooden formwork, the timbers are simply trimmed and will have a smooth surface after the concrete structure hardens.

First class wood molding

In this wooden mold, in addition to grating the wood, its seams are also covered with putty and sandpaper. These types of wooden molds have very stylish and beautiful architecture.

Concrete column molding using wood

Wooden forms are generally used for roofs and columns. This mold costs less than concrete or metal molds and is very suitable for people who want to finish a project with less cost and less area. At

the same time, it is possible to make a wooden mold with a lower budget, it is also very important to pay attention to the type of wood.

Column concreting

In buildings with a concrete structure, the column is made of rebar and concrete. Concrete should be in such a way that it maintains its paste state when pouring and setting and easily fills the space between the rebars. After this step, shaking should be done. This is done by a vibrator. In order to eliminate air bubbles from inside the concrete, it is better to vibrate vertically and leave the concrete slowly.

There are two methods for concreting columns:

In residential buildings whose height does not exceed 3 meters, the two-piece pouring method is used. In this method, a mold is placed and half of the concrete is poured into it and vibrated. Then the mold is placed and the rest of the concrete is poured. Of course, by placing the valve in the middle of the mold, you can pour the concrete in the lower part and then close the valve. In the second method, column concrete is poured using a pump. In this way, the pump pipe is lowered to a height of about one meter from the bottom of the column and concreting is done. Simultaneously with the concreting of the column, the pipe moves and rises. The important thing is that the concrete should be vibrated in the first moments and avoid the vibration of concrete that has been poured for some time.

How to implement column concreting

Concreting includes the following steps:

Concrete construction

Currently, concrete production is done only by batching method and other methods are obsolete. In the batching method, all the materials required and presented in the notified mixing plan are weighed separately and emptied into the mixer of the batching machine, and after a certain period of time, which depends on the type of

concrete, the weighed materials are poured. They are directed into the mixer and concreted and can be used in the desired area.

The first stage of concreting the column

It is better to moisten the substrate a little before starting this step. Then they pour the prepared concrete into the buckets and deliver it to the person who is on top of the column and fills the column with concrete.

After half of the column is filled, using a vibrator, the shaking operation begins so that the concrete vibrates when the vibrating hose enters the concrete.

The second stage of concreting the column

After the end of the first stage of vibration, concreting should continue until reaching the height specified in the concrete plan. To determine the exact height of the column based on the map, the height of the column is determined on the template and nails are hammered to mark it, and concreting is done up to the same part.

It is necessary to vibrate again after filling the column. Therefore, they vibrate upwards from the previous vibrating part. Remember that the height of concrete decreases after vibration. So, it is better to fill a little higher than the nail with concrete or pour a little concrete into the column after vibration.

Mold piping

Due to the applied pressures and vibrations, the formwork may be slightly out of alignment after concreting and column vibration, so the formwork is re-aligned after the completion of the second stage vibration. After performing the above steps and finishing the concrete of the column, after one day the concrete will be stuck and the mold must be removed. A sack is used to water the molds. The sack is wrapped around the column and the concrete is cured by soaking it.

Concreting tall columns

In tall columns, in order to prevent the separation of concrete components and the formation of seams in the column structure,

concreting must be done in two stages and in a completely principled manner. For this purpose, they first armor the columns. They use a narrow arrangement to restrain the armature of long columns. The important point in this matter is that it is mandatory to use strong anchors in five centimeters above and below the column concreting section. After strengthening, it is time to format the column. Because the concreting of long columns is done in two stages, there are openings in the molding of these columns. Vertical control of concreting forms is necessary in all stages of column concreting.

In the initial stage of concreting long columns, concreting is done through an intermediate valve and a vibrator. After finishing this stage, the valve is closed and the second stage of concreting is done from the top of the column.

Manual concreting of the column

In some small construction projects, due to the small volume of columns required, sometimes the required concrete is produced manually without sufficient supervision. Since the columns play the main role in bearing the incoming forces, it is recommended to use a bucket or a concrete column for concreting instead of using a shovel.

Concreting round columns

Concreting for round columns is quite similar to other columns. The only difference that makes the columns round is that the reinforcement of these types of columns is round. In molding these columns, they use a mold with a round cross-section radius so that the column resulting from concreting becomes round.

execution of beams (puter)

A beam is a structural element that primarily resists loads applied laterally to the axis of the beam (the element designed to carry the main axial load is a foundation or column). Its deflection mode is primarily by bending. Loads applied to the beam lead to reaction

forces at the support points of the beam. The total effect of all the forces on the beam is the creation of shear forces and bending

anchors inside the beams, which in turn causes tension, strain and internal deflection of the beam. Beams are characterized by their support, profile (section shape), balance conditions, length and material.

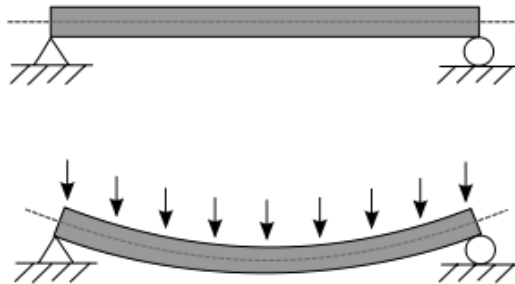

A statically determined beam bends under a uniformly distributed load

Overview

Beams were historically square timbers, but are also metal, stone, or a combination of wood and metal, such as flech beams. Beams mainly carry vertical gravity forces. They are also used to carry horizontal loads, such as earthquake or wind loads, or in tension to resist beam thrust as tie beams or (usually) compression as collar beams. The loads carried by the beam are transferred to the columns, walls or beams, which then transmit the force to the compression members of the adjacent structure. And finally to the ground. In light frame construction, joists may be placed over joists.



Steel beam

Beams may be made of wood, steel or other metals, reinforced or prestressed concrete, plastic, and even brickwork with metal rods in the foundation between the bricks.

Various types of beams are used in the construction of buildings and structures. These are horizontal structural elements that carry vertical loads, shear forces and bending moment. Beams transfer the applied loads along their length to their end points such as walls, columns, foundations, etc.

Types of beams in structures

There are different types of beams that are classified according to the following conditions:

- Based on support conditions
- Based on building materials
- Based on cross section shapes
- Based on geometry
- Based on equilibrium conditions
- Based on the construction method
- Based on support conditions

1. The beam is simply supported

It is one of the simplest structural elements, both ends of which rest on supports, but are free to rotate. It consists of a foundation support at one end and a roller support at the other end. Maintains shear and bending based on assigned load.

2. Fixed beam

It is supported at both ends and fixed to resist rotation. It is also called a built-in beam. Fixed ends create moments other than reaction.

3. Console beam

If a beam is fixed at one end and free at the other end, it is called a cantilever beam. The beam distributes the load to the support which

is forced against a moment and shear stress. Cantilever beams allow for a bay window, balcony and some bridges.

4. Foundation beam

A foundation beam has more than two supports that are distributed throughout its length.

Based on building materials

5. Reinforced concrete beams

As we know, it is made of concrete and reinforcement. Sometimes reinforced concrete beam is hidden in reinforced concrete slabs and it is called hidden beam or hidden beam.

6. Metal beams

It is made of steel and is used in several applications.

7. Wooden beams

Timber beams are made of wood and have been used in the past. However, the use of rebar in the construction industry is now significantly reduced.

8. Composite beams

Composite beams are made of two or more different materials such as steel and concrete.

Based on cross section shapes

There are several cross-sectional shapes of beams and they are used in different parts of structures. These beams can be made of reinforced concrete, steel or composite materials:

The shapes of reinforced concrete sections are:

9. Rectangular beam

This type of beam is widely used in the construction of reinforced concrete buildings and other structures.

10. T section beam

These types of beams are mostly made integrally with reinforced concrete slabs. Sometimes an isolated T-beam is made to increase the compressive strength of the concrete.

In addition, the inverted T-beam can also be made according to the applied loading requirements.

11. L-section beam

This type of beam is made integrally with a reinforced concrete slab around the structure.

The shapes of the metal section are:

There are different cross-section shapes of metal beams. Each cross-sectional shape has advantages over other shapes in a particular situation.

Square, rectangle, circle, I-shaped, T-shaped, H-shaped, C-shaped and tubular are examples of cross-sectional shapes of beams made of steel.

Based on geometry

12. Straight beam

A beam with a straight profile and most beams in structures are straight beams.

13. Curved beam

Beams with curved profiles, such as circular buildings.

Based on equilibrium conditions

15. Determining the beam static

For a given static beam, equilibrium conditions alone can be used to solve the reactions. The number of unknown reactions is equal to the number of equations.

16. Static indeterminate beam

For an indeterminate static beam, the equilibrium condition is not sufficient to solve the reactions. Therefore, the analysis of these types of beams is more complicated than statically determined beams.

Based on the construction method

17. Cast concrete beam in situ

This type of beam is made at the project site. Therefore, the forms are fixed first, then fresh concrete is poured and allowed to harden. Then, it is applied repeatedly.

18. Precast concrete beam

This type of beam is made in factories. Therefore, construction conditions are more controllable compared to on-site construction. As a result, the quality of beam concrete will be higher.

Different cross-sectional shapes can be produced such as T-beam, double T-beam, reverse T-beam and many more.

19. Prestressed concrete beam

Prestressed concrete beam is made by compressing the strands before applying the load on the beam. Prestressed concrete beams and post-tensioned concrete beams are types of pre-stressed concrete beams.

Other categories

20. Deep shot

A deep beam has a significant depth and according to the ACI code the ratio of span to depth is less than four. A significant load is transferred to the supports by a compressive force that combines load and reaction. As a result, the strain distribution is no longer assumed to be linear as in conventional beams.

21. Shooter

Metal sections are generally used for beams that bear heavy loads.

General forms

Most beams in reinforced concrete buildings have a rectangular section, but a more efficient section for the beam is the I or H section, which is usually seen in metal buildings. Due to the parallel axis theorem and the fact that most materials are far from the neutral axis, the second moment (torque) of the beam area increases, which in turn increases the stiffness.



A metal beam under a bridge

An I-beam is only the most efficient shape in one direction of bending: up and down looking at the profile as an I. If the beam bends from side to side, it acts as an H, where it is less efficient. The most efficient shape for both directions in two dimensions is a box (a square shell). The most efficient shape for bending in any direction is a cylindrical shell or tube. For one-way bending, the I or wide flange beam is superior.

Thin wall

Thin wall beam is a very useful type of beam (structure). The cross-section of thin-walled beams consists of thin panels connected to each other to create a closed or open cross-section of a beam (structure). Typical closed sections include round, square and rectangular tubes. Open sections include I-beams, T-beams, L- beams, etc. Thin-walled beams exist because their bending stiffness per unit cross-sectional area is much greater than that of solid cross-

sections such as bars. In this way, rigid beams with minimal weight can be achieved.

Implementation of the roof

Roof is an internal surface above the head that covers the upper part of a room. It is generally not considered a structural element, but rather a finished surface that hides the lower surface of the roof or floor structure of an upper floor. Ceilings can be decorated to taste, and there are excellent examples of murals and artwork on ceilings, especially in religious buildings. The roof can also be the upper limit of a tunnel.



Different types of roofs



California tract house with open beam roof, 1960

Types

Roofs are classified based on their appearance or structure. The cathedral roof of any area is a tall roof that resembles a church roof. A suspended ceiling is a ceiling where the finished surface is built from a few inches or centimeters to a few feet or meters below the structure above it. This may be done for aesthetic purposes, such as achieving the desired ceiling height. or practical purposes such as sound dampening or making room for HVAC or plumbing. The reverse of this will be a raised floor. A concave or barrel-shaped roof is curved or rounded upwards, usually for visual or acoustic value, while a coffered ceiling is divided into a grid of recessed square or octagonal plates, also called a "lacunar roof". The cove ceiling uses curved plaster between the wall and the ceiling. It is named for cove molding, molding with concave curve. A stretch ceiling (or stretch ceiling) uses a number of individual panels using a material such as PVC fixed to a perimeter rail.

Elements

Ceilings are often decorated with frescoes, mosaic tiles and other surfaces. While a coffered ceiling is difficult to implement (at least locally), it has the advantage of being largely protected from finger damage and dust. However, in the past, this was more than compensated for by smoke damage from candles or fireplaces.

Reference Book Of International Building Standards Chapter One
Many historic buildings have gable roofs. Perhaps the most famous ceiling of the Sistine Chapel is by Michelangelo.

Fire rated roofs

The most common roof that contributes to fire resistance ratings in commercial and residential construction is the drop roof. In the case of a dropped ceiling, the score is given by the entire system, which is the upper structure, from which the ceilings are suspended, which can be a concrete floor or a wooden floor, as well as the suspension mechanism and finally the lowest membrane or ceiling. has fallen. Between the structure from which the drop roof is suspended and the drop membrane, such as a T-bar roof or a layer of drywall, there is often space to run mechanical and electrical plumbing, wiring and ductwork.

home roof construction

Home roof construction is the framing and covering of the roof that is found in most independent houses in cold and temperate climates. Such roofs are mainly made of wood, they take different shapes and are covered with different materials. .



A roof shuttering in the United States around 1955

Modern wooden roofs are mainly framed by pairs of conventional beams or prefabricated wooden trusses that are connected by truss connection plates. Historic wood-framed buildings may be framed with original beams or wood roof trusses. Roofs are also determined as warm or cold roofs depending on the way they are designed and built, according to the insulation and thermal ventilation of the building. The slope of the pitched roof is primarily determined by

the roof covering material and aesthetic design. Flat roofs actually slope up to about ten degrees.

In areas with high winds, such as where a hurricane may make landfall, the primary engineering consideration is to keep the roof down during severe storms. Every component of the roof must withstand the forces of high wind speed. This is done using metal fittings that are attached to each truss. This is usually not a problem in areas not prone to high winds or extreme weather conditions.

Beam roof construction

The most common executive roof in concrete and metal buildings in Iran can be considered the block beam roof, which does not require an expert team and special technology, easy, cheap and fast implementation can be considered reasons for this claim. In terms of the load bearing system, the block beam roof is placed in the category of one-way slabs. A one-sided slab is a slab whose length to width ratio is greater than or equal to 2. The connection of the joists to the load-bearing beams in this roof is a joint connection. Also, if the criteria specified in publication 543 as well as the structural designer's calculations are observed in the implementation of these ceilings, it can be expected that this ceiling will show a suitable reaction against vibration during operation.

Truss roof construction

Prefabricated roof trusses come in a variety of styles. They are designed by the manufacturer for each specific building. Wooden trusses are also made in different styles using wooden or metal joints. Heavy wooden beams, usually spaced 240 cm (8 ft) to 370 cm (12 ft) apart, are called main beams. Main beams may be mixed with normal beams or carry normal grunts.

Designing

The roof framework must be designed to support the structural load, including what is called dead load, its own weight and the weight of the roof covering, and additional load called environmental load

such as snow and wind. If people can walk on flat roofs, they may need to be designed for live loads.

Roof Coatings

Roofing materials, including underlayment and roof covering, are primarily designed to shed water. Covering is also one of the main elements of architecture, so roof materials are available in many different colors and textures. The primary covering on homes in North America is asphalt shingles, but some have other types of roofs or metal roofs. Tile and thatched roofs are more common in Europe than in North America. Some roofing materials are designed to reflect light to help reduce air conditioning costs in hot climates.

Ventilation and insulation

Ventilation of the roof space is required to regulate the temperature in the roof space. Without proper ventilation, moisture can cause interstitial condensation in the roof fabric. This can lead to serious structural damage, wet or dry rot, and can ruin insulation.

Congestion in roof space is very problematic today because: much less random ventilation due to tighter building envelopes with high performance windows and doors and no chimneys. This tighter coating means that the air temperature in buildings has increased, the warmer the air in the building, the more water vapor the air can carry. As the occupied part of the building gets warmer, the roof space is cooler, with high insulation and roof membranes resulting in a cool roof space.

Basic technique of roof construction

In the Near East, from the time of the Romans, throughout the Middle Ages and until the beginning of the 20th century, the roofs of houses were built in the following way: they first placed wooden beams on the walls at a distance of about 60 cm. between each pole; Thin strips of wood or planks of wood or planks placed adjacent to each other were placed over them, each plank 3 fingers (6.75 cm) thick or slightly less. On top of these planks, a matte material woven together from natural plant fibers, such as reeds, beech leaves, or pafundancioneros, was firmly secured in place by the palm branches. They first laid a thick layer of clay, followed by a 20 cm

(7.9 in) thick layer of soil, then covered with a clay aggregate consisting of a clay cement mixture. Crushed rubble, clay and straw,

this type of roofing material is well equipped to resist moisture and rain.

Stairs construction

The construction of concrete stairs includes steps such as design, foundation preparation, building molding, placing metal reinforcement bars, concreting, finishing and processing. The construction of concrete stairs is a difficult task that requires the study of all aspects and the design of it, an engineer and a skilled workforce for its construction.

The following steps are included in the construction of concrete stairs:

1. Design of concrete stairs

Stair design requires knowledge about design aspects and site study. The factors that are effective in the design of the stairs are the height of the floor, the width of the stairs, the depth of the lift, the width of the thread, the thickness of the stairs, the angle of the stairs, the load on the stairs and many other things that require an expert engineer.

2. Foundation and support of concrete stairs

The foundation on which the concrete stairs are located must be properly constructed to successfully transfer the loads of the stairs to the ground and resist the movement of the stairs.

If there is a foundation beam of the building at the beginning of the staircase, metal reinforcement bars can be attached to them, which will transfer the loads. If no plinth beams are found, a small concrete or masonry foundation is constructed.

3. Making molds for concrete stairs

The most important step in the construction of concrete stairs is the use of a suitable mold. Flight angle, thread and riser dimensions should be checked properly. Usually, when building stairs attached to the wall, the flight line, thread and risers are specified to properly fix the shutter or molding on the wall.

Boards should be at least 2 inches thick to support the weight of the concrete. The entire form structure must be supported by 4x4 posts. Wooden boards are used to create stairs and are attached to the side structure of the mold with a few screws.

4. Metal reinforcements for concrete stairs

Concrete stairs should be reinforced with metal bars to carry the loads on the stairs and transfer them to the ground. The number of metal bars and the size of the bars should be calculated by structural engineers depending on the loads applied to the stairs.

These metal reinforcing bars are placed in the mold with a minimum distance of 25 mm and tied together.

5. Pouring concrete for concrete stairs

Pouring concrete into the molds starts from the bottom to the top. The concrete mixture plays an important role in the strength and durability of the stairs. The standard mixture used for stairs is 3 parts cement, 2 parts sand, 4 parts sand and water.

When pouring concrete, it is recommended to use a concrete vibrator to completely fill the gap of the stairs and prevent the formation of honeycombs.

6. Remove the molds

It takes at least 21 days for the stairs to dry completely, so the molds can be removed only after 21 days. In these 21 days, proper processing should be done to avoid cracks in the stairs due to thermal expansion.

After 21 days, the mold is removed using a hammer and crowbar. Work patiently so as not to damage the concrete or the edges of the steps.

7. Completion of concrete stairs

After removing the mold, the stairs can be finished in different ways according to the needs of use. It can only be finished using a trowel

or float to finish concrete, cement tiles, granite can be installed for a better look. Even carpet or wood can be used to complete the stairs.

Concreting beams, roof and staircase

Concreting of columns and beams in the workshop is done in two ways:

Column casting in two parts

In residential buildings where the height of the column is usually not more than 3 meters, a half formwork is used and half of the column concrete is poured and vibrated, then the rest of the formwork is placed and the rest of the concrete is poured. Or there is a valve in the middle of the mold from where the concrete from the bottom is poured and then the valve is closed.

Concreting with a pump

In this method, the pump pipe should be lowered to a height of at least one meter from the bottom of the column, and then, at the same time as concreting, concrete is poured and the pipe is raised. Unfortunately, in many cases, it is observed that concrete mixers, when they want to vibrate the concrete, introduce the vibration into the concrete and vibrate one point of the concrete for more than 20 seconds, which is completely wrong and causes the concrete mixture to It vibrates. Out of homogeneity and fine and coarse particles are separated and the concrete can no longer achieve the desired strength.

Important points about how to concretize columns and beams

If the ready concrete is brought by concrete transport machines (mixer), the following points should be paid attention to for correct concreting:

It is strictly forbidden to add water to transported concrete without the permission of the supervising engineer. (Usually, the workers add water to the concrete for ease and fluidity, which greatly reduces the strength of the concrete, so it is very important to pay attention to this.)

Usually, some of the concrete at the beginning of the discharge from the mixer has improper grading. Care must be taken not to use this

concrete, which has inappropriate quality for concreting, for construction works.

Before concreting, the inside of the reinforced foundation molds must be completely cleaned of loose soil and construction debris.

During concreting, it is mandatory to use a vibrating device, contractors are required to ensure the health of their vibrating device before starting concreting.

To remove air from concrete and increase the strength of concrete, it is necessary to use a concrete vibrator. Pouring concrete without shaking it will not create proper concrete.

In order for the foundation bricks not to absorb the concrete leachate, it is necessary to use a plastic coating.

Before starting concreting, the concreting bed should be moistened so that the concrete water does not leave the bed quickly. Care must be taken that water does not accumulate in the foundation and that there is only moisture.

Steps of concreting the roof

One of the most important steps in the architectural construction of a building is concreting the roof. Because the stability and resistance of any building against events such as earthquakes depends on the correct implementation of concreting. Concreting is one of the parts of construction that you must be very careful in doing and proceed according to the specified principles to ensure the safety of the building. You should know well that concreting is a process in which ready concrete is transported to the desired stages by a pump or crane.

Steps of concreting the roof

Some of the most important steps that must be followed and taken care of for concreting the roof are:

Concrete preparation

Before starting concreting, you should be sure of the quality of the concrete used in the construction and make sure it is suitable. You

should mix the concrete building materials based on the exact percentage so that the concrete does not suffer after some time. You can adjust the quantity or amount of each of the concrete ingredients according to the specified standards.

The advantage of using ready-mixed concrete is that you no longer need to mix materials and prepare concrete at the building site. In this case, you will avoid wasting raw materials.

Strengthening and molding

Another step that must be done for concreting the roof is molding and reinforcement. In the foundation of the building, a person who is a structural engineer calculates the load on the building by considering the number of floors and determines the number of reinforcements based on the floors.

Each of the engineers can use rebar or reinforcement with their own calculations. A very small space is kept around the rebars, which is related to placing the concrete forms. Apart from building foundation, columns and roofs also need molding and reinforcement.

Before concreting the roof, you need to do the beam and block reinforcement.

In the implementation of concrete roof structures, the beam is one of the most important equipment. You should know that other equipment such as concrete spinners will be used inside the concrete. You can use a plastic spacer to resist part of the concrete. There are many types of spinners, one of the best of which is the plastic spinner.

Concreting

After the reinforcement and molding stage, concrete must be poured in its parts. Since you need a lot of concrete in building construction, you can use different methods to transfer concrete. Among these methods, we can mention the monorail device or the elevator system.

Concreting on the roof should be done according to the specified steps and there should be no delay in doing it. Because the construction of the building must be integrated so that there is no gap in it.

Density of concrete

After pouring the concrete, it should be uniform. You should also make sure that there is no air between the layers of concrete. Because if there is air in the concrete, the concrete becomes porous and its strength decreases.

To prevent this from happening, you can use concrete smoothness or vibration. If the diameter of the concrete is less than 15 cm, they usually use a trowel to smooth it. But if the diameter of the poured concrete is more than the stated value, the trowel is not suitable for this work and a vibrator should be used.

Concreting the stairs

Concreting of the stairs is done in two ways: shoulder and slope. Molding in the staircase is done in two ways: molding the bottom of the stairs and molding the front of the stairs.

Stair molding

To mold the stair floor, first, the main and secondary blocks are placed in the spaces between the stair beams, then the plywood is cut in different dimensions and placed on the four blocks and stair beams, and finally, to prevent concrete from sticking to the molds, the surface of the molds are dipped in diesel. After forming the stair floor, they implement the stair floor reinforcements with 10 mm diameter reinforcements. Then, by specifying the stair line by the surveyor, stair bump armatures are executed, and at the end, the plywood impregnated with diesel is placed vertically in front of the stair as the stair front mold.

One of the implementation points of the staircase is how to format the staircase in concrete structures:

The width of the tread should be 120 cm on the side connected to the upper staircase, and 90 cm on the side connected to the lower

staircase. This 30 cm difference is compensated with the implementation of stepping stones. In molding the stair arm, the bottom mold is sufficient. Because its slope is less than 45 degrees. If this slope is more than 45 degrees, the upper mold must be executed.

Dimensions of each step:

The height of each step should be 18 cm and the bottom of each step should be between 32 and 33 cm. There are other standard dimensions that must be observed among the implementation points of the staircase.

Concreting the stairs

After framing and reinforcement, concrete work is done on the stairs. 10 cm thick stair concrete is applied on the entire surface of the stair.

Hardening operation

Building retrofitting is the first stage of the executive operation of building a building, which includes all the works that lead to the formation of the building. Basically, the steps of strengthening the building include all the operations that form the initial shape of the building, and this building is formed and designed in the wooden part of the building and becomes beautiful and habitable.

Hard work in the construction industry includes digging the building foundation, concreting the building foundation, installing columns and foundations, building walls, the hard work of the building, which in some definitions includes all concreting operations, porcelain seating, blocking, implementation of beams and columns. and plastering the walls and in the final execution of the roof of all buildings and in some other definitions it is the use of porcelain walls and porcelain tiles.

The difference between building stiffening operations and joinery:

The stiffening operation is related to the construction of the main skeleton of the building and includes: piling operations, foundation

concreting, porcelain seats, beams and columns, wind braces, shear walls, wall cladding and roof.

Carpentry operations are related to building decoration, which includes all operational operations except fixing, such as electroplating, insulation, stone work, tiling, painting, electrical work, installations, door and window installation.

Excavation of the building

The beginning of any building construction work begins with excavation. Excavation actually refers to smoothing and leveling a part of the earth, the ridges of which are removed and the depressions are leveled with the earth's surface. It means that all the lows and highs of the earth will be corrected.

In excavation operations, excavation is done up to a maximum depth of 60 cm. Excavation is done by hand or using large or small machines, depending on the type of land that will be mentioned later.

Preparation of land and lean concrete

In the construction of the building, after excavating, we must prepare the soil bed for the foundation. For this purpose, concrete with low cement (100 to 150 kg of cement per cubic meter of concrete) is used, which is called Meger concrete.

In this way, at least 10 cm of concrete with cement is poured on the soil and then it is smoothed with a trowel to prepare for concreting the foundations.

Reinforcement

Reinforcement is one of the most sensitive and precise parts of the building. Since all tensile forces in the building are supported by round rebars, from this point of view, utmost care and patience should be used in the strengthening of concrete buildings.

To determine the number of round bars, reinforcements and determine their diameter, we use two methods, one is calculation and the

other is adjustment. Before concreting, the reinforcement is approved by the supervising engineer.

Concreting

After molding and also reinforcement, concreting is done using concrete pumps (tower) in large construction projects and manually in low-rise buildings, which must be done carefully so that the vibration is fully applied. until the bubbles inside the concrete are removed and the strength of the concrete increases.

After a period of one to two weeks, depending on the geographical area, the next step can be started.

Building Structure

After the concrete under the building dries, the foundation heads are transparent and the vertical columns and the entire skeleton of the building must be built.

If a metal frame of the building is needed, the columns and frame of the building are completed with metal beams and columns, but if a concrete frame is needed, the building columns are created with concrete molds that are used. For this purpose, they pour the concrete and wait for it to dry.

Implementation of the roof

First, the beams should be placed on the main bridges (metal beams) at the desired levels. The space between the joists is filled with hollow blocks and after the installation of thermal rebars and additional rebars according to the executive plans, the roof slab concrete is poured. Regarding the time of dismantling the foundations and foundations of safety, the contents of Iran's concrete regulations must be observed.

Separating walls

With the porcelain blade of the walls, the general skeleton of the building is defined and the building will be recognizable. The stage after hardening is the joinery stage.

Joinery

Building carpentry includes the steps that are performed after the construction of the building (construction of the building, columns,

etc.) and sockets, installation of facilities such as pipes and building heating, and finally the installation of doors and windows according to the regulations.

Carpentry includes all operational operations except hard work and includes cladding, insulation, stone work, tiling, painting, electrical work, installations, door and window installation.

Construction carpentry stages

Wall construction (chinese wall) of the building

Shamsheh (chartresh wood) for the wall

Plaster and dirt on the walls

Whitening the walls

Kill the walls

Corner stone around the wall

The final flooring

Waterproofing services (wall insulation)

Building floor carpet

Tiling the walls of the building

types of roofs and types of building roofs (plaster or false ceiling)

Building facades

Secondary insulation

Cleaning steps

Wall construction of the building

A wall made of brick or stone or other materials mixed with cement mortar or lime sand or Bitard mortar. The facade of the wall (baru) can be made from the beginning continuous with the exterior facade and gradually raised so that each row of porcelain bricks is placed in front of the cut brick and behind it is pressed brick or other

materials. The thickness and resistance of each wall is directly related to its type of use.

darby (squared timber) for the wall

After the wall construction, considering that the blank walls are made of clay (brick wall construction without mortar), the accuracy of this type of fencing is very important in terms of verticality and alignment. The wall is leveled using a bullion. In this way, they first determine the highest point of the wall by eye (which is done on the surface of the facade) and then create a flat point in that place with plaster and trowel. After that, this point is moved down with a plumb line and a small surface is created with plaster and soil under the wall (rampart), then a point in the other corner of the wall (fence) is selected again with plaster and soil. They make it smooth and flat.

Plaster and soil on the walls

Sifted clay is required at this stage. First, you need to sift the clay and mix it with plaster in a certain ratio. The ratio of this mixture depends on the strength of the plaster or its speed, which depends on the type of plaster. The faster the plaster sets, the more clay is needed.

In most cases, they are usually satisfied with an approximate ratio of 50% soil and 50% gypsum. The reason for using soil in plaster and soil is that both the mortar becomes cheaper and the durability of the mortar.

Whitening the walls

After finishing the stage of plaster and soil and drying it, they start whitewashing.

Killing the walls

Due to the quick setting of plaster, its surface cannot be polished (smooth). For this reason, after the whitewashing stage and before the plaster mortar dries, a layer of sedum with a thickness of several tenths of millimeters is stretched over it and polished (smoothed)

with a trowel to obtain a completely smooth surface ready for painting.

color is a key in gypsum mortar, which does not harden anymore, and first the gypsum powder is passed through a very fine sieve, and then it is sprinkled in water like ordinary gypsum mortar, and it is prevented from hardening by mixing the mortar. We continue to stir continuously for about 15 minutes until the plaster achieves its maximum increase in volume.

This mortar is completely uniform and never hardens, but it dries due to surface evaporation of the water inside. Construction plaster is white in color and can be painted due to its smooth surface.

After this step, plastering can be done, which is creating beautiful shapes like flowers and reliefs on the ceiling.

Corner stone around the walls

Due to the fact that plaster is not resistant to moisture and rots quickly, in order to prevent moisture from reaching the plaster wall so that washing the floor of the building does not damage the plaster of the walls, the height of 10 to 15 cm is finished. Around the walls, they put a plaque called a cornice. They work with travertine, marble, etc., which is called cornice around the wall.

The final flooring

Renovation is done in a part of the building that forms the useful surface of halls, rooms, services, warehouses, etc. According to the location, the use of flooring is of various types, especially for the flooring of residential units, there are all cases. All kinds of luxurious and decorative materials such as mosaic or stone and glazed tiles and all kinds of parquet or other flooring.

Flooring is the installation of various structures such as ceramics, mosaics, etc. on the floors of halls and other parts of the building.

Sealing services (primary insulation)

This step is done as insulation of different parts of the floor of the halls, etc., in parts such as salted floors.

To make the floor carpet, first of all, a piece of shaded stone or mosaic of the same size is placed in the corners of each part so that it is leveled at four points. Then a thin and strong string is tied to the sides and the gunya line is moved 90 degrees to the corners. Then they spread the mortar on the ground and carpet the floor. Of course, they move the strings in order.

If the floor has a slope, i.e. if there is a salt floor in the service floor, we must cover the service area with smaller sized floor coverings. These dimensions depend on the size and smallness of the service because with large parts, the necessary slopes cannot be implemented in small places. But if the service floor does not have a slope, any size of flooring can be used for its carpet, such as ceramic, mosaic, stone, special floor tiles.

How to run the set square line

First, two strands of the corners are closed vertically and 60 cm is determined on one side and 80 cm on the adjacent side. In this case, the line connecting the two should be 100 cm. Instead, move the string to the 100 cm point. In this case, the angle is 90 degrees.

Tiling the walls of the building

To install tiles on the walls, they first level the tile with plaster or sand on the ground, and then install the tile in a level and vertical position and temporarily maintain their balance with a piece of fresh clay. Soft sand is made and the back is slowly filled in two or three stages.

After the tiles are completely dry, they are attached to the wall (with white cement).

Roof operations and types of building roofs (plaster or false ceiling)

At this stage, depending on the needs and usage of the building, various types of roof operations are used, including plastering, false ceiling, or...

Building facades

The facade of the building is the exterior of the building and is of particular importance. There are different facades, including brick facade, ceramic facade, etc.

The facade of the building should have a sufficient connection with the lower surface so that there is no risk of its separation and falling during an earthquake.

The facade must be able to withstand the specific climatic conditions of each region. For example, it should have good resistance against rain or not lose its shape against strong sun.

Avoid using heavy parts on the facade.

Secondary insulation

Secondary insulation consists of bituminous covering of parts such as exterior walls or roof of the building. When doing insulation with bitumen and coated bitumen sack, the following points should be observed.

Insulation is not allowed during rain.

Insulation is not allowed on wet surfaces.

Solid insulation should be applied while it is hot and flowing.

The temperature of bitumen used should not exceed +177 degrees Celsius.

Walking on insulated surfaces should be done with caution and using special shoes.

It is forbidden to use nails to close insulation layers.

The insulation layers should be overlapped by 10 cm on each side and firmly bonded with suitable bitumen. In overlapping layers, the upper layers should be placed side by side so that according to the gradient, water flows from them towards the layering.

When insulation is done in more than one layer, successive layers of insulation must be perpendicular to each other.

The insulated surfaces must be covered after the protective layer is completed.

Insulation should be done with ready-made waterproofing according to the methods recommended by the manufacturers.

It is necessary to create a suitable substrate for insulation.

Cleaning steps

This stage includes cleaning and delivery of the project to the customer.

Water and sewage piping

Sewer piping is one of the most important construction activities that must be done according to standard principles. In case of a mistake in the plumbing of the building, the possibility of replacing and repairing the pipes increases and the comfort of the residents is disturbed. As a result, repairs and replacements, while having a lot of costs, also affect the beauty of the building. In case of renovation, the plumbing of the building is executed as a facade, which imposes an unpleasant appearance on the building. Water transfer in important parts of the building and disposal of waste below and on the ground is done using the sewage and water supply piping system. Water taps are installed in the designated place with the help of pipe branches. Plumbing of the building is done with the help of fittings, intersections, three-way and valves.

Building plumbing

Why should building plumbing be standard?

The implementation of building plumbing in a standard way has advantages. But are you aware of these benefits? Among the advantages of basic implementation of sewage piping and building water supply, the following can be mentioned:

Proper control of water and waste movement and compliance with safety in the sewage piping system

Optimizing and preventing maintenance costs

Correct use of building plumbing equipment and facilities

Preventing reworking, repairing and changing the facade of the building

All of these should be applied with hygiene principles in mind. In designing the piping of the building, it should be noted that the pipes are not physically damaged or corroded along the way.

Types of building plumbing

Plumbing of the building should be done patiently and carefully by experienced people in the building. If the operation is not professional, it will be difficult to implement changes. The sewage piping system can be implemented in different ways, each of which has its own advantages and disadvantages. In the following, we will examine these methods.

Piping of the building by the traditional method of branching

In the traditional method that has been used since ancient times, the pipes are installed flat. In sewer branch piping, a large number of small and large branches are drawn from a main pipe to the entire building. In this way, the hot and cold water pipes are not separated. In the past, this type of building plumbing was done with the help of metal pipes, and nowadays it is done with polymer pipes.

Plumbing of the roof of the building

The possibility of damage to the pipes and repairs in the built-in sewage piping method is high. This factor caused a number of pipes to be installed on the walls. This method does not look beautiful. Of course, you can use the duct on the pipes to solve the internal design problem.

Collector piping

Today, building plumbing is done using a collector device. In this sewage piping method, every part of the building has branches. In case of water burst, the whole building will not be cut off. The amount of consumption and the number of units determine the number of collectors required.

Polymer and five-layer pipes are used in the piping of the building using the collector method. The quality of the pipes is high and the risk of bursting, sedimentation, pressure drop and corrosion is less for them.

Plumbing of the building under-roof method

The under- roof method is the newest type of sewage piping. In the installation under the roof, the pipes are installed in the ceiling instead of the floor. In this type, the use of five-layer pipe gives the best performance.

High flexibility of the pipes, no need for a large number of connections and elbows, and reducing the pressure on the pipes are among the advantages of this system. The repair and replacement speed is also very high.

Types of building plumbing based on materials

According to the type of pipes used, the plumbing system of the building will be different. Galvanized pipe, cast iron pipe, green pipe and 5 layers are the most widely used types in the sewage piping system. Galvanized pipe at a reasonable price with long life and wide applications can be a good option for you.

Galvanized pipes

Two types of metal or galvanized iron pipes can be used in building piping. In general, these pipes have a very high resistance to corrosion. Due to the lack of flexibility, the accuracy of the size of galvanized pipes is very important. Galvanized metal and iron pipes in 6-meter branches and two ribbed heads with a maximum diameter of 8 inches are used in building piping. Compared to the metal type, galvanized iron pipes have higher corrosion resistance against acids.

Cast iron pipes

Before plumbing the building, tap them with cast iron pipes and make sure that it is not broken due to the sound produced. The strength of

these pipes is increased by pouring molten lead on them. Apart from the difficulty of implementing cast iron sewer pipes,

these pipes have their own male and female and simply sink together. Do not forget that the mat must be placed in the direction of the sewage flow.

Polyprofondansionlen pipes (green pipe)

Green polymer pipes are more useful than metal ones. The light weight of these pipes, fast implementation, high resistance to rust, low sedimentation and reasonable price are the advantages of this type.

5 layer pipes

Corrosion and bursting in metal pipes leads to high losses. This factor caused the building's plumbing system to move towards new types of pipes. Although polymer pipes do not have the problems of metal pipes, oxygen penetration, resistance to pressure and high temperature, etc. are among their limitations. 5-layer pipes are new pipes that are produced from several layers of metal and polymer. These types, while increasing resistance and flexibility, reduce sedimentation and corrosion.

The start of construction piping foundation operations

The implementation of the sewage piping system must be done in accordance with the basic principles. If the basic points are ignored, the result of this system will not be confirmed. For this purpose, the plumbing of the building must be done in accordance with the following points:

Connections should be made with regard to preventing sedimentation.

Do not forget to seal and seal the pipes so that the bad smell does not penetrate into the building.

The route chosen for the building's piping system should prevent them from bursting.

Do not put too much pressure on the pipes.

It is better to install a device under the pipes to increase their resistance.

Important points in building plumbing

In sewage piping, in addition to the basic principles, other points should also be considered. Ignoring these principles affects the quality of the building's plumbing and its life.

For example, when constructing pipelines and laying pipes in the ground, the depth must be controlled. Depth or short distance from the surface are both unfavorable. Pipes that are close to the surface are subject to damage due to passing vehicles. On the other hand, pipes located at a high depth are exposed to damage due to high soil pressure. In addition, pay attention to the following in the plumbing of the building:

Pipes must be away from the freezing point. Freezing causes cracks and leaks.

Polymer pipes must be protected from sunlight.

Access to the pipes should be easy so that you do not face problems if repairs are needed.

Water pipes should be in a place where there is no wear, explosion or corrosion.

Drinking water passes through pipes and reaches people. The quality of the pipes should be such that it does not change the color and taste of the water. On the other hand, leaking pipes combine water with foreign materials.

Sewer piping should not be weak and low capacity. Pipes must have the capacity to transport waste to distant locations.

The sewer piping system must have a standard slope to prevent waste accumulation and clogging in the sewer path.

Drinking water reaching the residents of the building requires a standard pressure. A water pump is usually used to increase the water pressure. Also, the source should have a higher position than the water inlet.

Another important point is the entry of waste into the sewer. Pipes should discharge waste materials into special tanks for the disposal of human sewage or municipal sewage.

On the other hand, the unpleasant smell must be removed from the house through the ventilation pipe located above the roof.

In the design of the sewage piping system, it should be ensured that the sewage does not return due to floods and other such issues.

Heavy weight and pressure cause serious damage to pipes. The weight of the main and secondary valves and collectors should not be applied to the pipes.

Pipes can be implemented in two ways: facing and embedded. Outdoors, it is necessary to use insulation to protect the pipes.

Building plumbing type

Sewage piping and water supply are implemented in two ways under the floor or under the roof. Under the roof, the quality of materials, the durability of sewage piping and the execution time are higher. All these factors affect the price increase.

Materials and pipes

In building water piping, one of the most important factors affecting the final costs of the work is the price of the water pipe, which varies according to its type, brand, quality, and size. In addition, the type and quality of pipes also affect the cost of building plumbing. For example, if cast iron pipe is used, more skill and accuracy is required, which increases the price.

Work dimensions

The cost of implementing sewage piping for one section is different from the implementation of the entire building. It is worth noting that the cost of building plumbing will increase in the case of installing ventilation, air conditioning or siphon piping.

execution time

According to the type of work, the volume and difficulty of building plumbing time changes. Increased time increases costs.

The cost of building plumbing repairs

If the materials and pipes are not of sufficient quality or are not implemented according to the standard, they may leak, burst or corrode after a while. In this case, the cost of repairs is also added to the cost of sewage piping. A leak detector is used to detect a leak, which has a separate cost.

Signing a fire extinguishing and fire alarm contract with the fire service offices along with the approval of the technical engineering office

Obtaining fire department approval, strict compliance with safety rules and regulations in buildings leads to obtaining fire department approval. In order to receive fire department approval, it is necessary to comply with architectural safety, fire alarm systems, fire extinguishing systems and other systems required by the building and must be approved by the inspector of the fire department.

Obtaining address confirmation

Compliance with all safety regulations and instructions of the fire department and the correct and principled implementation of fire alarm and fire extinguishing systems in the building leads to obtaining fire department approval. In big cities, buildings with more than 5 floors must receive a fire certificate from the fire department at the end of the project in order to obtain the completion of the building work. Obtaining the fire department approval is one of the definite and necessary rules of the municipality to obtain the completion of the building work. Dear employers, by visiting the electronic services offices of the city to get the instructions issued by the fire department and check them carefully with the help of fire consulting companies, they will be aware of the process and how to implement these instructions and can accurately follow the fire safety regulations. Run the address. Consulting companies are with dear employers from the beginning of the work to the end (designing phase 1 maps and implementing fire alarm and extinguishing systems until obtaining fire department

approval and starting the commitment for repairs, service and maintenance).

After the implementation of the building safety instructions and the monitoring of its implementation by the fire consulting company and the request of the consulting company to visit the fire department, the visit of the project will be placed on the agenda of the prevention deputy of this organization, and the date and time of the visit will be informed to the consulting company. After the visit, the fire experts will announce the result of the visit to the consulting company through the system of the fire department (Cartable). In case of fire department approval, this organization confirms that the relevant project is approved by this organization in terms of safety and installed fire fighting equipment (fire alarm and extinguishing systems, etc.). Despite this approval, the employer can take action to obtain the completion of his building.

Which buildings need fire approval?

According to the city planning regulations of Tehran, buildings whose height is more than 23 meters from the street floor to the floor of the last floor, or commercial, office buildings, etc., which have a large fire load, and all buildings and specifically buildings below 6 floors that Their license was issued after 02/17/2019, they must receive the Tehran fire safety approval certificate from the municipality in order to obtain the completion of their building work. This certificate includes compliance with safety standards, architecture, fire alarm, fire extinguishing. In order to get the end of the work, it is mandatory to comply with these rules. The implementation of this work requires the presence of a fire consulting company in the stages of implementation and construction of the construction project in order to obtain fire approval. Finally, if all fire regulations are met, the project will be approved by the inspection expert of the fire department and approval will be issued.

What happens if you do not receive the fire department approval?

If the building's fire department approval is not received, the relevant building may have safety and fire department defects and

may cause irreparable risks during accidents and fires. Also, if the building is not approved by the fire department, the municipality will not issue the building completion certificate, and since the building completion certificate is a prerequisite for the ownership certificate, the ownership certificate will not be issued either. Therefore, the financial value of the relevant project is reduced and it has many financial losses for the employer in the foundation.

Contract steps and documents required to enter into a contract with consulting companies

The implementation of project instructions and all work steps are carried out by the inspection and control system of safety services, between the consulting companies and the fire department.

1- The owner refers to the executive company with all the following documents.

1-1- The principle and foundation of the ownership document

1-2- The original and the foundation of the national card of the owner or employer

1-3- Notarized power of attorney from all partners

1-4- CD architectural map and instruction sheet

1-5- Municipal automation letter

1-6- Two series of architectural plans sealed with the seal of the municipality

1-7- Safety and fire service fee payment slip

2- Setting up a consulting contract with the fire fighting company

3- Receiving and completing the form for appointing the executive company, sealed with the seal and signature of the company's managing director

4- The company's activity regarding that case must be marked in the form for determining the executing company according to the instructions.

5- After receiving the form, the owner goes to the electronic service offices and by registering the mentioned form, he specifies and announces his consultant company. As a result, the company's access to the file will be opened and the work will be done according to the legal procedure.

6- After completing this process, the consultant company is obligated and committed to carry out the project work in accordance with the regulations and submit the work report to the organization at certain times.

Companies are allowed for this process that are approved in the list of qualified companies of the fire department, including safety in architecture, fire detection systems, fire extinguishing systems, ventilation systems and exhaust fans. Other companies, their activities are only allowed to cover the metal frame, and some are only allowed for the ventilation system and exhaust fan, whose field of activity is in the same case.

Fire department approval form

The fire department approval form is sent to the municipality by the fire department and upon completion of all the processes and visits of the fire department to the project, a checklist and form is prepared and approved by the organization's expert, and the final form is sealed and signed by the honorable director. Prevention is sent to the municipality and the municipality issues the termination of the work. It should be noted that this form is sent to the municipality by the automation system of the fire department, and it is not allowed to receive this form manually if it is submitted to the owner, and in all management processes and visits, only the automation number of this form is presented to the owner. By receiving this automation number, the owner is sure that the approval procedures of the fire department have been completed, and after 48 hours, the original form of the same number will be sent to the municipality. Then he goes to the municipality and continues all the administrative procedures until he receives the completion certificate and the certificate of operation of the building.

A complete guide to obtaining a fire department approval

First, the employer must conclude a contract with the consulting company and the fire service executive, and by completing the form for filing the fire service file, introduce his consulting company in the electronic services offices of the city. The following steps are followed.

1. Design and drawing of notification, extinguishing and exhaust systems in accordance with the standards and regulations by the consulting company and send it to the fire department for approval.
2. Presenting architectural tips and regulations to the client and holding briefing sessions for project fire alarm and extinguishing contractors
3. Starting the executive work of fire alarm and extinguishing systems, fire protection coatings, etc.
4. Supervising the purchase and installation of equipment approved by the fire department (all alarm equipment, fire extinguishers, fire doors, etc. must have the product authenticity form and approved by the fire department)
5. After the architecture is completed and the building is equipped with fire fighting systems and there are no defects, the equipment is tested and the final supervision is carried out on the correct implementation of the architectural rules.
6. Preparation of documents to obtain a visit from the fire department
7. Notarization of repair, service and maintenance commitment contract with fire fighting companies
8. If the first visit and dry test are approved, the necessary measures will be taken for the second visit of the fire department.
9. Issuance of fire department approval

Pars Heating and Cooling Engineering Safety Company, with its experienced staff, as a fire fighting company, is ready to guide, advise and obtain approval for you, dear customers.

Vendor list of fire department

The fire service vendor list is a list of companies approved by the fire service organization in the field of safety, fire service consulting, etc. These companies operate under the supervision of the fire department. Due to the wide range of safety laws and guidelines, the fire department has introduced qualified companies for consulting in the field of safety and firefighting on its site. Dear employers, by referring to this site, they can visit the list of fire department approved companies and easily communicate with the above companies. In fact, firefighting consulting companies are the interface between the firefighting organization and the employer and are responsible for monitoring how the project is implemented from the beginning to the end.

Fire approval for the building

The certificate issued by the Tehran Fire Organization regarding the approval of building architecture safety and the correct implementation of fire fighting systems is called fire certification. Fire department approval is one of the concerns of respected employers of construction projects. According to the new regulations of the fire department, the lack of awareness of the construction employers about the new regulations and to prevent safety problems for the owners, to speed up the process of following up the case and reduce the building costs, the presence of a fire consultant from the list of companies approved by the fire department in It is necessary to obtain the approval of the fire department.

Validity of fire department approval

The fire department approval is a prerequisite for obtaining the completion of the building work and is issued only for obtaining the completion of the work. Usually, its validity period is limited (6 months to 1 year). If the employer does not take action to obtain the termination of the work during this time, he must take action to obtain the fire department's approval again.

Building firefighting instructions

Every building that has a file with the fire department has fire instructions. Firefighting instructions include a series of architectural safety compliance and implementation of fire alarm and extinguishing systems, installation of fireproof doors, implementation of fireproof coating, implementation of ventilation and exhaust systems, etc. The items in the instructions must be done according to the rules and regulations of the fire department and under the supervision of fire department experts.

Confirmation of fire alarm

Fire alarm system approved by the fire department

All buildings with 5 floors and above need to install and implement fire alarm systems in the building in order to fully implement safety measures. The installation and implementation of fire alarm systems must be done under the supervision of companies approved by the fire department, and the operators must use the equipment approved by the fire department.

fire extinguishing system approved by the fire department

All buildings with 5 floors and above need to install and implement fire extinguishing systems in the building in order to fully implement the safety measures, and they will not be able to complete the work until the safety measures are fully implemented. The installation and implementation of fire extinguishing systems must be done under the supervision of companies approved by the fire department, and the operators must use the equipment approved by the fire department.

Implementation of gasification of units

Building gas supply is one of the important processes in any construction, which must be implemented in accordance with the rules of the engineering system. Gas is very important and is used as the main source of fuel in today's homes. Any disregard for the basic implementation of building gas supply and the use of standard equipment can lead to irreparable events.

Implementation of building gas supply

Safety in building gas supply is very important and must be done with high skill. Gassing is an important task that must be done according to principles. Supervisor approval is not issued without following the correct path. The gas supply of the building is carried out according to the following steps:

- Filing a case in the engineering system organization
- Determine supervisor
- Designation of contractors or executors
- Complete piping
- Obtain supervisor's approval
- Implementation of gas stove and Meter

Gas piping is done in two ways: surface and built-in:

Built-in building gas supply

In the gasification of the built-in building, due to the different execution method and lack of observation of the connections, the welding of the pipes is different. In this method, seamless metal connections or so-called Mannheim pipes are used. There are standard pipes that have uniform connections and their welding is professional and flawless.

Gasification of the facade of the building

In addition to metal pipes, various types of copper or brass pipes can also be used in the gas supply of facade buildings. Therefore, in addition to the price of iron, the price of other alloys also affects the cost price of the building. The welding of facing pipes is done by electric welding method and using welding dynamo. Gear joints are usually not used in this type of building gasification.

Important points in the gasification of facade buildings

It is recommended that the color of the facing pipes be different from the color of the environment.

Covered pipes are exposed to impact and pressure. Therefore, their leakage should be checked periodically.

For ease of cleaning and to prevent the accumulation of grease and pollution, the pipes should be one centimeter away from the wall.

In this method of gassing the building, it is forbidden to pass the gas pipes without protecting the door and window frames. Also, pipes should not be installed inside ventilation channels, chimneys, ventilation and elevators.

Pipes that are installed in a built-in way will be more resistant to impact, corrosion and damage. During construction, it is better to use the built-in type. It is worth noting that the built-in pipes are hardly subject to periodic inspection due to the type of implementation. The cost of this type of building gasification is higher than the coating type.

The best method during building renovation and gas pipeline repairs is to gas the building in person. In this method of gassing the building, branching is done easily and the necessary checks can be done periodically. Branchability is one of the advantages of face gasification.

Bending of building gas pipes

In building gas supply, some pipes need to be bent. When bending gas pipes, the following principles should be considered:

Special equipment must be used to bend the pipe.

Bending area should be free of peripheral weld line.

Mechanically, corrosion or cracks should not be seen on the bend of the pipes.

Bending arc should not be more than 90 degrees.

The inner curvature radius of the bend should be 6 times the outer diameter of the pipe at most.

The distance between the bend and the pipe and other connections is important. This distance should not be less than 20 times the nominal diameter of the pipe.

Principles of building gas supply

In general, special attention should be paid to the gas supply of the building in order to confirm the safety of the work at the end.

The most important of these points are:

It should be ensured that the foundations of the pipe support (supports) are stable on the wall.

It is mandatory to observe the standard distance of supporting foundations.

Pipes that are exposed to rain corrosion, pipes that are placed inside the wall or pipes under the supports need to be completely painted.

The pipe must be glued at least in two layers at the support.

It should be noted that the gas pipes of the building do not interfere with the privacy of the neighbors.

Pipes should be standard 6 meters.

Install a lock valve at the beginning of the main pipe.

The cable should not be more than 25 cm away from the meter.

The valves should be opened clockwise.

Valves and chimneys should be installed on the same wall.

Poles should have a standard distance from each other.

If several branches are taken from one branch, the horizontal distance between two risers should be at least 12 cm.

The distance between the riser and the wall is 5 cm.

Each of the different units of the building must have its own meter.

Avoid branching in a space that is less than 12 meters.

In the gas supply of the building, the connection of the pipe and the counter is done.

The main length from Alamek to meter should not be more than 25 meters.

Pipe type in building gas supply

Normally, pipes with metal alloys such as metal and polyethylene pipes are used in building gasification.

Polyethylene plastic pipes and compression coupling are one of the materials used in building gasification.

These pipes must be standardized and approved before use. Polyethylene pipes are widely used in the gas supply of built-in buildings. These types of pipes and other plastic connections must have the following specifications:

wiring

Electrical wiring is an electrical installation of cabling and related devices such as switches, distribution boards, sockets and light fittings in a structure.

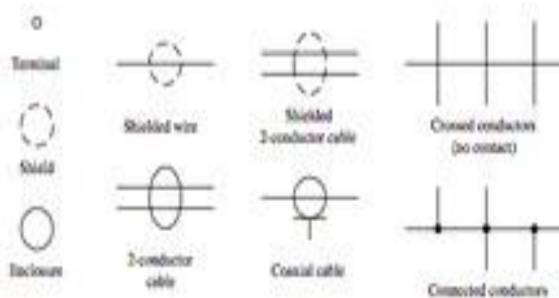

Electrical symbols for wiring

Wiring is subject to safety standards for design and installation. The permitted types and sizes of wire and cable are determined by the working voltage of the circuit and the capability of electric current, with further limitations in environmental conditions, such as the range of ambient temperature, humidity levels, and exposure to sunlight and chemicals.

Circuit protection, control and related distribution equipment in the building wiring system are subject to voltage, current and performance specifications. Wiring safety codes vary by location,

country or region. The International Electrotechnical Commission (IEC) is trying to harmonize wiring standards among member

countries, but significant variations in design and installation requirements still exist.

Wiring regulations and regulations

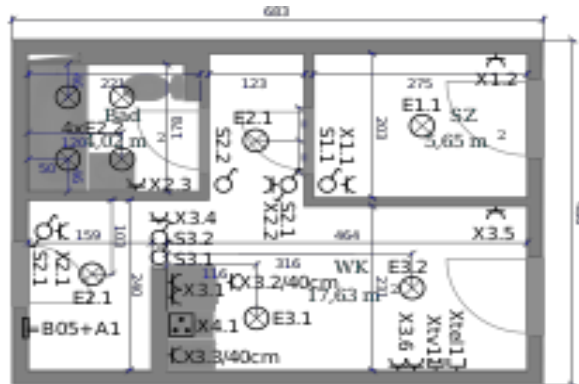

House wiring layout plan

Color coding of wiring by region



Colored wires in a flexible plastic electrical conduit commonly found in modern European homes

In a typical electrical code, wire color coding is mandatory. There are many local rules and exceptions in each country, state or region. Older installations differ in color codes, and colors may fade as insulation is exposed to heat, light, and foundation.

Wiring methods



Installation of building electrical wiring

Materials for wiring internal electrical systems in buildings vary depending on:

- Intended use and amount of power required in the circuit
- Occupancy type and building size
- National and local regulations
- The environment in which the wiring must work.

Wires and cables are rated based on the circuit voltage, temperature, and environmental conditions (moisture, sunlight, oil, chemicals) in which they can be used. A wire or cable has a voltage rating (to neutral) and a maximum conductor surface temperature rating. The amount of current that a cable or wire can safely carry depends on the installation conditions.

Cables

Modern wiring materials

Modern non-metallic sheathed cables, such as the NMB and NMC (US and Canada) types, consist of two to four wires covered with thermoplastic insulation, plus a grounding wire, surrounded by a flexible plastic sheath. . In North America and the UK this conductor is usually bare wire, but in the UK it is required that this bare protective earth (PE) conductor be encased in green/yellow insulated tubing where the cable sheath has been removed. Most other jurisdictions now require that the protective earth conductor be insulated to the same standard as current-carrying conductors with green/yellow insulation.

Copper conductors

Electrical devices often use copper conductors because of its properties, including high electrical conductivity, tensile strength, ductility, creep resistance, corrosion resistance, thermal conductivity, coefficient of thermal expansion, solderability, resistance to electrical overload, They are compatible with electrical insulation and easy. Copper installation is used in many types of electrical wiring.

Aluminum conductors

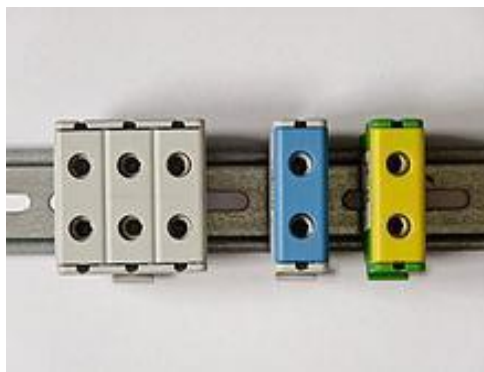

Terminal blocks for connecting aluminum and copper conductors

Cable routes



Electrical conduit risers seen inside the fire rated shaft

Insulated wires may run between electrical devices in one of several ways. This may be a specialized bendable pipe, called a conduit, or one of several types of metal (hard steel or aluminum) or non-metal (PVC) or (HDPE) pipe. If many circuits are required, metal recesses or PVC with rectangular cross-section (North America) or trunking (UK) used. Wires run underground may be run in plastic pipes encased in concrete, but metal elbows may be used in high tension wire. Cabling in exposed areas, for example factory floors, may be run in cable trays or rectangular raceways with doors.

Where wiring or conduits that support wiring must pass through fire-rated walls and floors, openings must be closed in accordance with local building codes. Where safety-critical wiring must remain active in the event of an accidental fire, insulation must be applied to maintain circuit integrity in a manner consistent with the product certification listing. The nature and thickness of any passive fireproofing materials used in connection with wiring and conduits has a significant effect on capacity reduction, as the thermal insulation properties required for fire resistance also inhibit air cooling of electrical conductors.



The cable tray can be used in stores and homes

Cable trays are used in industrial areas where many insulated cables run together. Individual cables can be removed from the tray at any point, simplifying wiring installation and reducing the labor cost of installing new cables. Power cables may have connectors in the tray to maintain spacing between conductors, but small control wiring is often installed without any intentional spacing between cables.

Basic wiring methods

The first indoor electrical wiring systems used bare or cloth-covered conductors, which were secured by staples to the building frame or to running boards. Where the conductors passed through the walls, they were protected with cloth tape. Connections were made like telegraph connections and soldered for security. The underground conductors were insulated with earth-soaked cloth tape wraps and placed in wooden recesses, which were then buried. Such wiring systems were unsatisfactory because of the risk of electric shock and fire, plus the high labor cost of such installations.

Handle and tube wiring



Handle and tube wiring (the orange cable is an unrelated connection wire)

The first standard method of wiring in buildings, used in North America from about 1880 to 1930, was K&T knob and tube wiring: single conductors were passed through openings between structural members in walls and ceilings with ceramic tubes. Protective channels through joists and ceramic handles attached to structural members to provide air between the wire and timber and support the wires. Since air was free to circulate over the wires, smaller conductors could be used than cables. By arranging the wires on opposite sides of the structural members of the building, some protection was provided against the short circuit that could be caused by driving a nail into both conductors at the same time.

Metal sheathed wires



Electrical cable with lead casing in a house in the south of England

In Britain, an early form of insulated cable, introduced in 1896, consisted of two paper-insulated conductors wrapped in a lead sheath. The connections were soldered and special connections were used for the lamp and key holder. These cables were similar to the underground telegraph and telephone cables of that time. Paper-insulated cables were unsuitable for indoor wiring installation, as very careful work was required on the lead sheaths to ensure that moisture did not affect the insulation.

A system later invented in Britain in 1908 used vulcanized rubber-insulated wire enclosed in a strip metal sheath. A metal sheath was attached to each metal wiring device to ensure continuity of ground connection.

The system developed in Germany called "Kohlo wire" used one, two or three rubber insulated wires in a brass or lead sheet iron pipe with a crimped seam. The housing can also be used as a return conductor. Kohello wire can be run on surfaces and painted or embedded in plaster. Special junction and outlet boxes for lamps and switches are made of porcelain or sheet metal. The crimped seam was not as waterproof as the Stannos wire used in the UK, which had a solder sheath.

A somewhat similar system called "concentric wiring" was introduced in the United States around 1905. In this system, an insulated electrical wire was wrapped with copper tape, which was then soldered to form the ground (return) conductor of the wiring system. The bare metal sheath, at ground potential, was considered safe to touch. While companies such as General Electric manufactured fittings for this system and a few buildings were wired with it, it was never adopted into the US National Electric Code. The drawbacks of the system were that special connections were required and any failure in the pod connection would result in the pod being ignited.

Other historical wiring methods

Armored cables with two rubber-insulated conductors in a flexible metal sheath were used as early as 1906, and at the time were considered a better method than knob-and-tube wiring, although much more expensive.

The first rubber insulated cables for wiring US buildings in 1922 with US Patent No. 1,458,803, Burley, Harry and Ronnie, Henry, "Insulated Electric Wire", issued 06-12-1923, to Boston insulated wire and cable was introduced. These were two or more solid copper electrical wires with rubber insulation, plus woven cotton cloth over each conductor to protect the insulation, with an overall woven jacket, usually coated with bitumen to protect against moisture. Wax paper was used as filler and separator.

Over time, rubber-insulated cables become brittle due to exposure to atmospheric oxygen, so they must be handled with care and are usually replaced during refurbishment. When switches, outlets, or light fixtures are replaced, simply tightening the connections may strip the hardened insulation from the conductors. The rubber insulation further inside the cable is often in better condition than the insulation placed in the joints due to reduced exposure to oxygen.

The sulfur in the vulcanized rubber insulation attacks the bare copper wire, so the conductors are tinned to prevent this. When rubber was not used, the conductors were stripped.

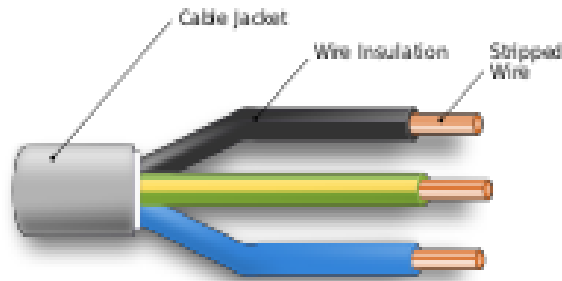

Diagram of a simple power cable with three insulated conductors, with IEC color scheme

Around 1950, VC insulation and foundation jackets were introduced, especially for residential wiring. Around the same time, single conductors with thinner PVC insulation and a thin nylon jacket (eg US Type THN, THHN, etc.) became common.

The simplest form of cable has two insulated conductors twisted together to form a single unit. Such unsheathed cables with two (or more) conductors are used only for very low voltage signals and control applications such as doorbell wiring.

Implementation of the sample unit

One of the solutions for selling residential or office units is the decoration and furniture of the sample unit. This makes customers have a better visualization when using the unit and helps to encourage buyers to buy.

Rabbiting

Rabbits are mesh metal nets that are used before final plastering and for the purpose of foundation, and Rabbits nets are connected to the sub-grid with special wire or wires.

Of course, the presence of horizontal and vertical bars on the roof is necessary to keep them stable.

levels

The most common way to run Rabbits is a 3-step method:

First step: installing hanging rods

These rebars are either already buried in the main roof or they are welded to the roof or its beams during the construction. The main task of the rebars is to bear the main load of the false ceiling. The pre-buried rebars in the roof are expected to be in place before the implementation of the rigid roof, so that during the implementation of Rabbits, part of the rebars protrudes from the roof and Ravis rides on them.

These rebars are bent in the next steps and connected to other rebars in the welding process. The distance between the bars is very important and should not be more than 60 cm. This distance is about 30 cm in heavy roofs with special designs.

Second step: installing the rabbits net

At this stage, the rabbit nets are placed on the bars and secured. Rabbits-shaped lace sheets are usually divided according to the number of bridges they have (9, 11, 13, etc.). The rabbits are made of steel so that it can be easily welded. It should also not be forgotten that in order to prevent the plaster from falling, you should use rabbits with more bridges and more weight. Instead of welding, you can use galvanized wires, which are also known as rabbit wire. The rivet wire helps to connect the metal mesh to the substructure built in the first step. Although the variety of this product in the building materials market is very high, it exists. There is no specific standard in the preparation of rabbits and it cannot be said that one type is better than another.

Third stage: Plastering

The third step, which is actually the final step, is done after installing Rabbits. At this stage of the work, the metal mesh is filled with plaster and a uniform white surface is created. Usually, the plastering stage is repeated several times so that the plaster layer covers the lace of the rabbits well and the designs desired by the client are created. Rabbitsbanding can be troublesome and tedious, and its implementation is not suitable for everyone. If Bond Rabbits falls into

the hands of unprofessional and inexperienced people, you cannot expect to achieve the desired result.

Dimensions of rabbits

Rabbits are mainly produced in dimensions of 60 x 240 cm and an area of about 14.4 square meters. Taking into account the possible errors, one rabbit equals 14 square meters of area. To calculate the number of rabbits needed for the building, just divide the work area by this number. Our Rabbits are of two types in terms of structure:

By Columns: A Rabbits sheet contains a certain number of columns, which are named accordingly.

Based on weight: Each sheet of Rabbits has its own weight based on the thickness of the sheet used in its construction.

Implementation applications of rabbits facades

The implementation of the face of Rabbits provides us with a uniform surface of the wall. The Rabbits network ensures the overall continuity of the wall and prevents any separation and cracking. Due to its surface smoothing feature, Rabbits is a suitable option for false ceilings, plastering, repair of construction cracks, cement concrete coating and suitable for any change in home decoration. One of the reasons for the popularity of rabbits in building construction is its use to create a suitable platform for installing electrical and mechanical installations. Also used to hide features.

But the most important use of rabbits facades

Today, with the changes that have been made in construction, we see the design of composite or multi-layer facades, the way of their implementation is completely different from the previous facades, that is why materials are used to smooth the walls.

On the other hand, to combine different materials, we need different layers, which is answered by the implementation of Nama Rabbits.

Rabbits false ceiling is one of the most used types of false ceiling. The structure of this roof is generally made of rods and corners, and its top is made of galvanized grids and plaster. The name Rabbits false ceiling is adapted from the upper galvanized grids called Rabbits.

Appropriate execution speed, material availability, high design and many expert staff are among the advantages of choosing this roof.

Relatively high weight, high consumption of plaster, low execution speed and atmospheric restrictions in the execution of the plaster layer are among the disadvantages of Raviz roof.

Rabbits stepped ceiling ceiling applications

To cover the facilities, cover the skeleton with light and simple or patterned beautification materials or Rabbits stepped ceiling components.

Bearing corners

The bearing corner, by connecting to the hanging bars, performs the main role of transferring the load of the false ceiling to the hanging bars and the main ceiling.

The minimum size of these corners is 3 cm and the maximum depends on the load and distance of the corners and its free length, which is used up to 5 cm. The maximum distance in simple roofs with normal load is 60 cm. It is mandatory to use the corners next to the roof.

In general, the maximum length of the console under the bar is 15 cm.

Conservative rabbits

It is a net that is formed by connecting thin wires to a series of main galvanized foundations that are made by forming galvanized sheet and are called bridges.

Bridges are divided into two categories: main bridges and secondary bridges.

Galvanized wires

Galvanized wire, also known as Rabbits wire, is a wire of maximum 0.8 mm with galvanized metal material, which is softer than reinforced and rustproof wire.

This wire connects the Rabbits network to the sub-rebars and even the bearing corners and to each other.

Plaster or cement coating

According to the prepared design and the placement of the false ceiling with a false facade exposed to moisture, open air or exposed to the facade, the covering of the rabbits is done with plaster or cement.

Implementation with any of the materials that can be done includes 2 steps:

1. Filling the holes of Tori Rabbits: This step involves a lot of consumption of this material and even a lot of waste when using white plaster. It is necessary to use quick plaster (solid material) to prevent swelling.

The main consumption of white plaster is at this stage, and the operator's experience has a significant effect in preventing the wastage of materials.

2. It is the final coating that is carefully polished to create a uniform and smooth surface.

General installation

At first, the hangers are connected to the metal beams of the ceiling in the desired places according to the design.

It should be noted that welded hangers cannot be used in concrete roofs and chromite slabs, and it is necessary to carry out the burial hanger before installing the concrete roof. Because the lower wing of the chromite and concrete roof bars is not designed and has the ability to be welded and bear the load of the false roof.

Then, by running a level line (which is done by a laser level or a level hose), the hangers are marked and the extra hangers are cut at the desired points, then the corners of the hangers are connected to the hanger bars by welding. The minimum size of these corners is 3 cm, and if the distance between the corners is more than each other, the size should be increased.

The maximum distance in simple roofs is about 60 cm, and the use of a corner on the side of the roof (corner) is mandatory.

By connecting the sub-rebars at a distance of 15 to 25 to the corners of the hemel with at least 2 cm of welding, the plan is formed, and then the Rabbits net is connected to the sub-rebars with galvanized wires. It should be noted that at least 7 to 10 cm of overlap should be considered in the places where the rabbit nets meet each other, and in the place of this overlap, the net should be connected to each other with the rabbit wire.

Rabbits bars

The closing of the rabbits net to the secondary bars should be done in such a way that the net is completely tight and connected to the bars at points close to each other. In all stages of implementation, it is mandatory to control the level of different parts and the main roof at all points of the roof. Even in simple and unplanned roofs, this leveling is very necessary, and controlling it in different places is one of the most important tasks, because nothing can be done for this difference in the stage of whitewashing and coating. When implementing the level difference in different designs, the minimum applicable level difference is 3 cm. There is no limit to the maximum level difference.

Facade windows and aluminum doors

Glass facades are a modern architectural solution that is popular in the construction of individual and commercial buildings.

Façade systems are used to cover large openings, entire facades and roof structures with glass. We use wood, aluminum or a combination of these materials for glazing systems. Forms vary from rectangular, trapezoidal to circular, arched and curved.

Assembly of modular facade glass systems allows for their partial assembly in the factory and complete assembly at the construction site. Almost all facade systems can include built-in windows that operate manually or automatically.

Metal doors and warehouse doors

The warehouse door is one of the most important doors in the building. In apartment buildings, storage rooms are usually located on the ground floor next to the parking lot. The design and color of the storage door is the same for all the apartments in the same building. Since extra household items, old items and antiques are stored in the warehouse, the warehouse door should be highly secure in addition to beauty. There are different types of storage doors

Welding of the rafters and around the roof

Welding is one of the basic skills that anyone who works with metals has. Its main purpose is to connect two separate objects. In most cases, workers weld thermoplastics and metals, such as metal frames, using fillers called welding rods. Many consider welding to be a necessary process to make buildings or structures last longer. For this purpose, welders use different techniques.

As welding has become a necessity in the manufacturing, automotive and construction industries, many people have developed their welding skills. While welding skills are generally essential for employment in the industries listed, they are even more valuable because welders can take on independent construction projects. This way, they can save money because they don't have to hire someone else to do the job, and they can customize the design of whatever end product they're looking to create.

Common welding methods

Metalworkers must know the different types of welding so that they can apply the right types in different situations. In general, melting metals or thermoplastic materials requires more than one type of welding. From preparation to finishing touches, here are the most common types of welding to be aware of:

Vine welding

Welders do welding when they want to hold metals in place. This type requires only soft welding points because it is intended to join

the material for a short period of time. Welders should avoid applying too much pressure to the point where the welds are hard to break.

Adhesive welding is also done to ensure the level and strength of the material. However, first and foremost, welders must consider the quality and type of metals they are using. These characteristics affect the durability of the joint and the number of spots welded during the process.

Shielded metal arc welding

This process is also called wood welding. Just like tack welding, this method uses sticks or rods to connect materials. But in this case, the workers use a metal rod coated with electrode flux and the workpiece to be welded. The melting of the rod and the workpiece causes welding.

Gas tungsten arc welding

For this, the worker uses an electric arc. Metals are welded with a tungsten-based electrode instead of the usual metal stick. During the process, workers may or may not use fillers. Because tungsten does not burn or dissolve, gas tungsten arc welding is preferred by those working in air and automotive shops.

Gas metal arc welding

In gas metal arc welding, a shielding gas and an electrode are used to weld the components together. Apart from that, this type of welding is known to protect the workpieces from contamination. Many welders use this method to join aluminum and steel in cars.

Arc welding with flux core

It is often used for thick and heavy metals and consists of a continuously fed hollow tube filled with flux. Like the two previous welding methods mentioned, this type welds the electrode and the main material.

Construction welding

Welding preparation

Before welding, workers must make sure that the metals are free of rust, dirt and grease, especially the parts to be joined. In most cases, welders clean the parts with cotton cloths or high-pressure washers if the dirt has hardened and rusted.

Wear protective clothing

Welders must keep themselves safe during welding processes such as soldering, joining and cutting metals. In these conditions, workers are exposed to radiation, sparks, fumes and other welding hazards. Such factors may cause eye damage and burns. In some cases, workers may even be electrocuted.

To prevent accidents, welders can use personal protective equipment (PPE), helmets, and most importantly, safety glasses.

Setting up the workpiece and workspace

Workers often set up a platform for welding. However, they must ensure that their workplace is safe and clean to avoid injuries and other problems. Scheduled cleanup should be done before starting or continuing the project.

Proper movement and position of the rod

Place the bars at an oblique angle - approximately 15 degrees from vertical, the bar should move in a straight direction. In addition, the length of the arch should be neither too long nor too short.

Hit the arc

Welders can be scratched or hit with the end of the flux and the end of the electrode. The time spent scraping and tapping depends on how deep or stuck the welder wants the metal parts to be. In other words, the stronger the metal bond, the longer the welder must scrape or tap.

Create a good weld

The quality of the weld determines the material and bond strength of the connected metals. In most cases, good welds have the following characteristics:

It is often welded in a straight direction.

It does not burst in the middle.

It is completely melted.

Well filled in the main ingredients.

For better results, welders refine their welds and beads by removing slag and other weak parts of the weld.

Cleaning the workpiece and workspace

Cleaning should always be part of the welding process. It reduces the possibility of injury after work and other problems. Typically, workers or a team of cleaners use household cleaning solutions such as baking soda for slags and flour and peroxide for burn marks. For the finished workpiece, a wire brush is the usual cleaning method used.

Obtaining the end of the construction

At first, the question may arise for some, what operations are considered in the construction of the solid component of the building because some contractors may not provide correct and complete information to the owner or operator of the building due to various reasons. In this article, it has been tried to briefly describe all the steps from the beginning of obtaining a building permit to the end, so that it can be used by all people, even those who have no experience in this field.

Obtaining a construction permit (building permit)

As a builder or owner of a building, after obtaining suitable land with the intended use for construction, you must first go to the

competent building authority of that area and file a case by presenting your land and ownership documents. After filing the case

and obtaining the drawing order sheet, the relevant authority can refer to one of the authorized offices of the engineering system organization of that region and get advice from a good and creative engineer to prepare the architectural drawings of the building. Do it yourself, after that, deliver the plans to the competent authority and prepare structural plans after getting approval to refer the plans to the engineering office. One of the most important and necessary tasks after obtaining a license is obtaining a water and electricity rating. Because you need these two important things to perform the hardening operation.

Building facade

The facade is usually the front or exterior of the building.



Carlo Maderno's historic view of the Church of St. Fundacion in Vatican City



The facade of the Pantheon in Paris was lit up at night on May 27, 2015 for the entrance of Germaine Tillion, Geneve de Gaulle-Antonioz, Fondationnaire Brussault and Jean-Ze to the mausoleum

In architecture, the facade of a building is often the most important aspect from a design standpoint, as it sets the tone for the rest of the building. From an engineering point of view, the facade is also very important due to its effect on energy efficiency. For historic facades, many local zoning regulations or other laws greatly restrict or even prohibit their alteration.

Types of facades for buildings

The facade, next to the roof, is one of the most important elements of the building, because it acts as a primary barrier against external weather factors that can damage the health of the structure, such as rain, snow, wind, frost, sun, etc.

For this reason, it is important to choose a facade system that protects against these risks while helping to achieve lower energy consumption, lower maintenance costs and improve occupant comfort.

- Light facade
- heavy facade
- Assembled
- Traditional
- ETI systems
- Rain cover

Light facade

It is a type of facade that attaches to the strong structure of the building, but does not form part of it. Since it does not contribute to the stability of the building, the lightweight facade must be designed to withstand the loads that exert pressure on its components. Materials that are commonly used for metal cladding include glass and metal.

heavy facade

As the name suggests, this type of facade tends to be made of construction materials with considerable weight. For a façade to be

considered heavyweight, the average weight, including solid and hollow elements, must be above 100 kg/m².

Prefabricated

This type of facade mainly consists of prefabricated modules that are connected to each other or assembled on site. The components of these facades are made industrially in highly mechanized factories and wooden and concrete panels are often used.

Traditional

This classification includes facades that use traditional building materials such as brick, stone, wood, ceramics, rendering, etc.

ETI systems

ETI (external thermal insulation) systems involve the installation of sheets of insulating material around the building, protected by mortar and glued or mechanically fixed to the retaining wall.

Rainproof cover

The rain cover or ventilated facade system consists of a load-bearing wall, an insulation layer and cladding material, which is fixed to the building using a supporting structure. The main difference between this system and the ETI system is that it has an air cavity between the bearing wall and the cladding material.

Although this system is more expensive and complicated to install, it is often a cost-effective option because the air gap is responsible for many of the benefits of the rain screen coating.

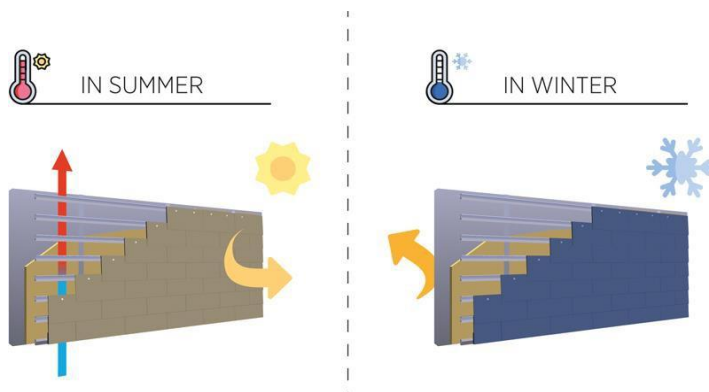

The "chimney effect" that occurs inside the air cavity means that warm air rises up and out of the facade. In the summer months, this phenomenon of natural convection means air renewal, which prevents overheating. On the other hand, in winter, the air does not heat up much and remains inside the house. Heat is not lost, which helps save energy from heating.

Facade in construction

After plastering or brickwork, the process that has a protective effect on the outside of the building is called facade. This process is the process that reveals the appearance of the building. Façade systems are made with very different materials. These can be processes such as styrofoam coating, glass coating, and metal coating. The main purpose of facades made of this or other materials is to protect the building. The facade in construction is one of the essential factors to guarantee the longer life of the building. But the advantages of facade systems in construction are not only the durability of the building.

Features of facade systems

Although the features of facade systems differ according to the materials used in the wall system, all facade systems have some common features.

Facade systems are resistant to water and moisture. However, this durability may vary depending on the type of product selected. The ratio of resistance to water and moisture of metal facade system and resistance to water and moisture of styrofoam materials are different from each other.

Facade systems have protective properties against the building and the interior of the building against radiation and ultraviolet rays. In other words, the covered surfaces of a building contribute to the health of the building.

Coated exterior walls have mechanical resistance to vibration, pressure and wind wear. The most important factor affecting the

strength of this feature is the covering material on the external walls.

All facade systems can offer customers many design alternatives. Thanks to designs that are limited by human imagination, choosing the right facade systems for any building is not that difficult.

Metal is a material that makes the best use of the common features of the facade systems mentioned above. Especially expanded metals provide great convenience for wall covering systems.

Signing an elevator contract with standard approval

In most new construction projects, elevator contractors work as subcontractors to general contractors. Because of this relationship, the customer of the elevator company before the completion of the project is the general contractors to whom the financial turnover of the elevator equipment is done.

Maintenance contracts

The four main types of elevator maintenance contracts offer you a wide range of coverage options. The more risk you take, the lower the service fee.

Complete maintenance

Under a full maintenance contract, the manager contracts with the elevator service company to take full responsibility for the elevator equipment specified in the contract. This service is sold as insurance and is intended to address all of the manager's concerns regarding elevator problems. It also minimizes the company's liability for claims in case of accidents or injuries. If there is a problem with the elevator, regardless of size, it is covered by the contract. Since the maintenance contractor assumes all the responsibilities, it determines the frequency of visits to the building.

Parts, Oil and Grease (POG)

A POG contract may be a desirable solution for companies with large space, extensive elevator systems, skilled elevator mechanics and the financial resources to self-insure the elevator system. The building owner must also be willing to shoulder the burden of

coordination between what is covered in the contract and what is done by internal staff.

A POG contract lists certain items of equipment not covered by the contract, such as elevator cars, motor-generator sets, and re-cabling. This contract specifies the frequency of inspections and trouble calls that must be answered. To be effective, a POG contract must clearly state the work to be covered and the parts to be supplied. Contractors are only responsible for the items covered by the contract. Elevator contractors usually charge less than the full maintenance contract price and the coverage is relatively less.

Oil and grease (OG)

The basic theory behind an oil and grease (OG) contract was that a knowledgeable in-house mechanic would inspect the elevator equipment on a regular schedule, lubricate the moving parts, and report any potential problems to the property manager. The property manager will pay for the necessary repairs. The cost of the OG contract is relatively low; However, when you factor in repairs, the total cost is usually much higher and more difficult to budget for.

Survey and report

Coverage under an inspection and reporting contract includes inspection and testing of all major equipment components. This inspection does not include equipment disassembly or any maintenance or repairs that require elevator mechanics. Recommended maintenance or replacement may be completed by the owner or by contract at the direction of the owner.

Contract terms

Once you've agreed with an elevator maintenance company, a contract specifies the services to be provided and how those services will be paid for. The agreement addresses a number of key issues discussed below.

Proportion

When a maintenance company takes over an existing elevator system, it may want to include a list of fitment items. This list provides the elevator components that the maintenance company believes will

need replacement soon and is unwilling to incur the full cost. In principle, the company and the building owner agree to

share the cost of possible wear and tear components. Additionally, some vendors offer occupancy discounts if a large portion of a building remains vacant for an extended period of time.

Exclusions

In addition to the items to be covered and the items to be split by the maintenance company, a maintenance contract also includes a list of exclusions: a list of components that are not covered by the maintenance contract. Such incidents that occur regularly can increase bills by up to 15% for an elevator service company. The responsible manager can control these costs by insisting that any complaints be investigated by building personnel before elevator maintenance contractors are called.

Responsibility

Determining responsibility for accidents is important. Owners are responsible for the actions of their employees and the safety of the equipment under their control. Any contract other than full maintenance puts the owner in a position where it is difficult to demonstrate that the system is not under his control. Most insurance plans cover this risk. However, the owner must be careful to avoid inheriting the legal responsibility to defend the actions of others through contractual hold harmless clauses. Allowing these clauses to be included in a contract may result in a reduction in the maintenance price, but the price reduction may not be a bargain because of the increased liability. The organizational structure of many companies makes it very easy to finalize such a contract without informing the insurance or legal staff of the existence of such clauses.

Elevator service companies are only responsible for components specifically identified in their service contracts. Unless the accident damage is specifically related to the part that the maintenance company serviced (or failed), it will be very difficult for the building owner to avoid liability for the accidents that occur.

Pricing elevator companies do the billing in advance at the beginning of each month. This is especially true of full maintenance

contracts, as they protect your equipment in a way not unlike insurance, in addition to providing preventative maintenance.

Usually, elevator contracts cover a period of 5 years and a termination clause requires 90 days written notice. These terms can be modified as needed, as can the automatic renewal clause. The trade-off with the building owner is cost versus flexibility. The shorter the contract, the more flexibility you have to re-instate and switch to other contractors, but shorter contract rates are likely to be higher.

Most contracts are divided into material costs and labor costs. Pricing under turnkey maintenance contracts is usually split into a percentage for materials and the remainder for labor. For example, the price under a full maintenance contract might be 25% for materials and 75% for labor.

Companies have different procedures for annual price adjustments. The problem with the annual price adjustment approach occurs when cumulative increases are applied. After several years, the adjusted price may be higher than the price the contractors originally paid to receive the work.

Procedures for obtaining standard approval for elevators

Ensuring all elevator installation and commissioning operations and finishing all construction and electrification operations and other related operations

Sending the foundation from the first page of the building permit and the foundation of the national card of the applicant to the company

Online registration by participating in the tracking code and identification of the inspection company

Paying the inspection fee and providing the deposit receipt to the company

Sending the map and other documents and submitting the supervising engineer form by the company to the inspection company

Waiting for the announcement of the inspection date by the company

Inspection of the elevator by the relevant inspector with the presence of the company's representative and the removal of possible defects until the final inspection of the inspector's final approval

A one-year service and maintenance contract between the employer and the contractors

Sending the foundation equal to the original one-year service and maintenance contract and elevator insurance policy to the inspection company to complete the file

Preparation of the elevator standard approval certificate by the inspection company and its delivery to the employer

Digging a water well

Reasons for digging sewage wells

1. Loss of efficiency of the old well of the building.
2. Lack of absorption of incoming water.
3. Intermittent filling of the well and lack of effect of draining the well on its efficiency.
4. Unsuitability of the old well for building and the need to build a new well.
5. The construction of a new building should be done according to the type of building, digging a suitable sewage well.
6. The risk of the old well collapsing, in which case the old well must be completely filled and a new well must be dug in another part.

The effect of soil type on digging sewage wells

The depth of the well depends on the soil and location of the area. The type of soil in different areas is divided into 3 types:

Clay soil: This type of soil has very little absorption and retains water (like cotton).

Sandy soil: This type of soil has a very high water absorption and water easily penetrates and moves downwards.

Sandy soil (windy sand): water absorption in this type of soil is weak and after absorbing a small amount of water, the soil becomes saturated.

Sewer well drilling site

The first step in digging a sewage well is to determine the appropriate location for excavation, which should be determined by an expert according to the conditions of the building. Digging a suitable sewage well for a building requires special expertise that every ordinary person cannot do.

The well drilling site should be a place with less traffic. As under the stairs, backyard, etc., the well should be close to the vertical sewer pipes to avoid horizontal sewage piping as much as possible because the risk of horizontal pipes being blocked is higher.

If we have to dig wells in high-traffic areas such as corridors or the floor of the kitchen or reception, we must cover it with a concrete slab after making the collar. The collar of the well prevents people from falling into it.

Sewer well drilling standards

The location of the well in the building should be at a suitable distance from the foundation and columns.

The ventilation pipe must be connected to remove the smelly and harmful gases from the well.

The location of the well opening should be determined in such a way that it can be easily found if necessary to repair or drain the well.

In the building plan, it is better to specify the exact location of the well, the depth of the rod and its storage volume.

The well should be dug in a place where it is possible to drain the well at regular intervals.

Before digging a sewage well, the coordinates of other wells should be checked. In such a way that no other well is dug within a radius of three meters.

Digging a well next to a garden or planting a tree next to a well causes destruction.

Do not pass hot and cold water pipes over the well opening.

After checking the soil conditions in the designated place for digging a sewage well, the relevant expert will determine the right type of well for you and proceed to dig the sewage well.

The best time to dig a sewage well

The best time to dig a deep well and dredging is when the underground water level has reached its lowest level, which in our country is in the second half of summer before the start of rain, and if you plan to dig a well for your building, it is better. Act now. Keep this important point in mind that you can create complete safety against lightning by using an earth well.

Slope of the roof and primary bituminous waterproofing

Slope execution is all about detail and precise execution that needs to be done right.

More rotation to move and direct the water so that it has enough traction.

It prevents the passage of water and moisture to the lower ceiling.

For external spaces such as:

Landscaping, paving, yard construction, and small slopes such as roof slopes for bathrooms, toilets, bathrooms, kitchens, etc.

The floor of any part of the building that is in contact with water, such as the roof floor, kitchen floor and bathroom floor, must be sloped and insulated.

Roof slope percentage

The way water moves should be such that the movement and stretching of water or waste materials from the origin to the destination is done without obstacles and at the maximum possible speed.

This slope percentage is considered to be less for guiding and stretching water and more for moving waste. In any case, the standard slope is about 5% for waste and 1-3% for sewage. Observance of these items will not cause technical problems of congestion and congestion on the route.

Slope construction methods

1. Soil leveling:

Leveling of surfaces for lands that have a gentle slope and preparing the next steps on the obtained surface for subgrade, paving, asphalt in one or two layers.

2. Blocking:

It is usually used in dividing streets and sidewalks and in public places and private open spaces.

First, the block foundation is done at a certain height using a leveling device (camera) or leveling hose or leveling tape.

The required slope is installed on a flat surface using cement sand mortar with sufficient grade of block in line with the drawn string.

Then the two sides of the installed blocks are restrained with concrete and the prepared path is covered with steps such as foundation and paving stones and finally asphalt or mosaic.

It should be noted that if the place is covered with mosaic, the mosaic ivories do not create an obstacle in the direction of water movement so that the water can be drawn as quickly and easily as possible.

3. Tilting:

If the area does not have a slope, it should be created by raising a sufficient percentage of the starting point with various materials such as embankment, concrete or other materials of the required volume.

4. Sifting:

When the slope is for building a yard, the volume of the slope can be created from materials such as ordinary bricks and cement or clay blocks. He leveled the holes of the obtained surfaces with the existing splinters and prepared the base of the cement sand cover and on it the carpet mosaic or bitumen and coated asphalt. It should be noted that in yard landscaping, the substructure is directly at risk of freezing the floor.

If cement-sand is added to the sewage mixture, the foundation will be much better and there will be no risk of lifting the floor.

Materials required for the slope:

- Welding of brick factories
- Brick chips
- burnt coal
- Iron smelting factory foam
- Mineral or industrial pumice stone
- Concrete foam and...

Implementation of slope:

The movement of the slope is towards the stud hole, and the hole location is installed in two ways.

Beam hole in the middle of the roof:

In this case, it is done in such a way that the slope length of the points is calculated.

The height of the four corners of the roof is determined by chrome plating.

Threading between chromes is done by the loading process.

A smooth and thin chrome is taken at the place of the stud hole.

The stringing device between the lateral and middle chromes, i.e. (stud hole), is done with a barge in the direction of the sloping parts.

The parts obtained between the ingots, which are called lakhki, are filled with the desired material and the slope is obtained by dragging the surface between the two ingots.

(moisture insulation) What is bituminous waterproofing?

Bituminous waterproofing (moisture insulation) is a very suitable coating against moisture penetration. For years, this material has replaced bitumen to cover various parts of buildings, including roofs, swimming pools, toilets, etc. In the past, artificial and natural bitumen has been a good choice for insulating different parts of the building. But today, Izogams have become the first choice of building builders with greater resistance and easier installation. Of course, the main ingredient of this product is bitumen. Bitumen is available in natural and synthetic varieties.

Bituminous waterproofing materials

This product may be made of different layers and parts according to the manufacturing method and final quality. But in general, what can be seen in the types of this product, the layers are as follows:

Woven polyethylene Polyester,

other additives **Building**

foundation insulation

One of the basic problems that can be seen in most structures is the contact with damp ground and the problem of damp and humidity, which sometimes causes irreparable damages such as rotting of wood, rusting of irons, proliferation of banana insects and swelling of the outer layer of plaster. and the only way to deal with it is moisture insulation. Of course, insulation requires sufficient precision and the use of high-quality materials.

Ways to attract moisture to the wall of the building

1- Infiltration of moisture through the ground and the foundation of the building: in this case, in order to prevent moisture from entering, the wall should be raised to the level of the porcelain tile, and the foundation of the building should be cemented first, then insulated, and then the porcelain wall should be installed again. Let's start insulation.

2- Infiltration of moisture through the body of the wall: If we live in the rainy areas of our country, with diagonal rain in these areas, moisture and humidity may penetrate into the house through the body of the wall and cause erosion and destruction of the house. To deal with this example, we must cover the body of the house from the outside with moisture insulation such as bitumen or Bituminous waterproofing.

Building foundation insulation methods

A- Bituminous waterproofing installation

According to Iran's waterproofing standard, these insulations are divided into two general categories:

- 1-prefabricated waterproofing for building foundation (Bituminous waterproofing foundation)
- 2-Prefabricated waterproofing for external surfaces such as body and roof (Bituminous waterproofing roof)

B- tar

tar is the most common waterproofing after bituminous waterproofing. For foundation sack bitumen, first we cover the surface of the foundation with a layer of bitumen, then we spread a layer of sackcloth on it, and after this process, we cover the desired surface with special bitumen.

Since the price of bituminous waterproofing is lower than that of tar, bituminous waterproofing is used more than others and in a common way in Iran to prevent moisture.

Bituminous waterproofing sanitary and bathroom services

Installers may choose different ways to install isogam in the bathroom. But many details and important points are common in the installation process and all the methods are based on it. Even the price of insulation for sanitary facilities is different and not the same according to the area of the environment, the amount of materials used and many other factors.

Bituminous waterproofing implementation of the bathroom

In the previous part, we said that the cost of installing and implementing isogam in the bathroom depends on various factors. The type and brand of this insulation can reduce or increase its installation cost. Some isogams require a special infrastructure, or special tools and equipment must be used to install them, or the process of sticking them on surfaces may be time-consuming.

The next factor is the size of the space to be insulated. Naturally, the bigger the space, the more bituminous waterproofing it needs. This issue increases the price of sanitary ware and increases the cost of its installation and operation. Of course, this depends on the installer. Some professional bituminous waterproofing installers charge more for doing this work and in return they guarantee the quality of work and durability.

The correct method of bituminous waterproofing

When we talk about bituminous waterproofing in the bathroom, they often think that they can easily install wide Izogam sheets inside the bathroom and everything will be over. But it is definitely not that easy to install and you have to go through several steps to implement it.

infrastructure

Before implementing bituminous waterproofing, a complete and accurate infrastructure must be done. This infrastructure includes cementing the bathroom floor. The cementing of the floor should be very even and smooth. If you have a salt floor in your bathroom, in addition to cement, the floor must also be sloped. Before

implementing bituminous waterproofing, the bathroom floor must be completely dry and free of any moisture.

If your bathroom has a window, the cement will dry in a day. Cement should dry at room temperature. Therefore, do not use good foundation and heating devices to dry it because it will cause the cement to crack.

Bituminous waterproofing and tiling

To install bituminous waterproofing, you need to start from the walls. At this stage, the bituminous waterproofing of the wall and the floor is not done together. Because with the movement of workers and tile workers, there is a possibility of puncture of the bituminous waterproofing. During the implementation of the bituminous waterproofing of the walls, usually a little of the bituminous waterproofing is also performed on the floor, and in the next step, the bituminous waterproofing of the floor is connected to it.

It should be noted that usually the bituminous waterproofing of the walls in bathrooms that have a shower cabin is not implemented on all walls up to a height of 180 cm, and this issue is implemented only for the shower cabin part. If the employer wishes, the rest of the walls will be leveled up to a height of 10 or 20 cm, and this will reduce costs.

After the implementation of the final covering of the walls, it is time to implement the floor bituminous waterproofing. The point is that the bituminous waterproofing of the wall must be on the bituminous waterproofing of the floor. Therefore, during the execution of the floor bituminous waterproofing, the wall is slightly raised due to the heat of the bituminous waterproofing and the floor bituminous waterproofing is stuck under it.

The reason is that the water and moisture that penetrates through the joint between the walls does not penetrate into the space under the isogam and does not cause moisture. In the execution of the floor bituminous waterproofing, make sure that the service sewer pipe and the salt floor are well covered so that water does not penetrate through this part.

Avoid cutting the toilet drain pipe as it will be very difficult to install after the flooring is installed. Plastering the inside of sewer and water pipes during insulation prevents them from being blocked by bitumen.

Important tips for bathroom insulation

To insulate the bathroom with Izogam, immediately after cementing the floor by the building and its complete drying, you must cut the excess sewer pipe with a file and level it with the floor.

One of the mistakes that many Izogam workers make is that they cut the pipe installed for the toilet, and after ceramic work and raising the height of the service floor, when the toilet is installed by the installer, the connection is done well. Therefore, the pipe that the insulator should not cut is the 12 cm toilet pipe. Cold and hot water piping in the bathroom isogam may be damaged due to the closed space and the heat caused by the isogam lamp. For this reason, before doing any work, you should cover the pipes with plaster and then perform insulation work.

Obtaining water and sewage branches

The water meter of the houses is intended for supplying water to the house. This meter is installed at the beginning of the entrance door, one side of which is the main water line and the other side of the pipes inside the house. The meter actually calculates the amount of consumption of a family in a specific period of one month or two months. In this article, we are going to get to know the steps of applying for a water meter and its essential points.

Necessary conditions for accepting the water meter branch request

In order to be able to have piped water in the land or the house we are building, we have to go through some steps. But before that, our conditions as applicants are also very high. In fact, any natural or legal person can apply for any residential, commercial, public, manufacturing, etc., in the service area of the relevant water and

sewage company or any change in the water and sewage distribution, and this request must be mandatory. It has been

registered in the water and sewage company. For this request to be valid, it must have the following conditions:

1. The water and sewage company where the building or land is constructed has the necessary capacity and facilities to create or change the branch of the applicant or can provide it.
2. The building or land desired by the applicant is completely enclosed and separate from other buildings, and the top and bottom of the road in the property are determined by the municipality.
3. There should not be an obstacle for the excavation of water and sewage company.
4. The applicant must not have a debt that is related to the application for changing the branch.

It is necessary and mandatory to have a water and sewage branch for each other, and all owners located within the scope of the sewage collection and disposal plan are required to submit a request for the installation of a sewage branch to the relevant authority. During the time that water and sewage companies and devices warn or announce. Otherwise, the water and sewerage companies will be allowed to cut off the water to these properties. Re-establishment of water depends on the request to install a sewer branch and pay for it.

Branching of non-domestic sewage provided that the quality of sewage at the time of discharge at the point of connection to the collection network is left to the discretion of the company and based on the relevant regulations and standards.

The mentioned cases are among the conditions that the water and sewage company has considered for allocating branches to properties.

Obtaining electrical power branch

Electric energy is one of the necessities of today's apartment living. Today, the presence of electricity in people's lives has made life easier. The existence of electricity has made it possible to use

electrical appliances such as vacuum cleaners, washing machines, air conditioners, refrigerators, televisions, and enjoy their benefits in life more easily. Electric energy in power plants is obtained through fossil fuels, also a part of the country's electricity is obtained through wind energy, water and nuclear energy. The electricity produced in these places is transferred from special wires and cables to cities and residential houses and industrial factories. Today, electricity plays a colorful role in people's lives to the point where it is very difficult to live without electricity. As mentioned earlier, the existence of electricity is one of the necessities of today's people. To benefit from the blessing of electricity in your home, you have to go through a series of administrative tasks so that you can benefit from this God-given blessing.

Necessary measures to receive electricity meter

Owners who intend to buy electricity distribution for their building can go to the website of the electricity distribution company and register their electricity distribution request from the electronic service desk of the electricity distribution company. The creation of an electronic service desk has minimized people's in-person visits. In this section, we discuss the steps required to apply for electricity distribution and explain each of these steps.

1. In order to register a request for electricity branching, people must first go to the website of the electricity department of their province and register their request for electricity branching there. In order to be able to register your electricity branch request, you must have scanned images of your identification documents, such as a national card, an image of a one-page property document, and an image of a building permit issued by the municipality. so that you can upload them to the site if necessary. After completing the application registration, you will be given a tracking code, and relevant experts will check your application and inform you about the progress of the work through Fundansionamak.
2. In the next step, if the registration of your application is done well, the relevant experts after the necessary checks will enter your application to the stage where it is necessary for these

experts to visit the building site to check the accuracy of the uploaded documents. In the assurance of the site. At this stage, the experts prepare the technical report of their visit. After going through the mentioned steps, the electronic electricity supply contract will be sent to you and after checking it, you will confirm this electronic contract on the mentioned site. At the end of this section, you must settle the costs and the invoice issued for the contract.

3. At the end, after going through the above steps and making sure that the application is approved, you should refer to the companies that make electrical panels, be careful that these companies must be approved by the Electricity Department. After buying the electricity meter, you should install it in a suitable place so that later the experts of the electricity department will visit your building and connect your electricity branch to the meter.

Drilling an earthing well with the approval of the electricity company

When the phase wires are fully connected to the earth wire, the fuse for that phase operates and interrupts the current and when the neutral wire is completely connected to the earth wire, if the earth circuit has a life protection fuse (FI) be This 30 mA fuse interrupts the leakage current and completely interrupts the phase and neutral current.

It is important to mention that the earth wire and the neutral wire are very similar to each other in terms of being without electricity, but in practice these two wires are independent of each other and their functions are different and it is never possible. It is used elsewhere to change from one to the other.

Today, earthing systems are as useful as electricity itself and are of great importance.

Lightning arrester networks without earth wires are practically useless because very sensitive and accurate earthing systems are needed to prevent network noise in telecommunications, and this

system is also widely used in electricity transmission and distribution networks.

The main reason for earthing in the electrical network is safety.

The purpose of digging an earth well or earthing:

Safety of human lives, buildings and equipment

To save human life from the risk of electrocution or death by inserting a fuse to create an alternative path for the current to flow without danger to the user.

To protect buildings, machinery and household appliances in hazardous conditions

To ensure that all conductive parts are not exposed to dangerous potentials.

Creating a safe path for the dispersion of lightning and short circuit currents

Creating a stable foundation for the operation of sensitive electronic equipment, to maintain the voltage in each part of the electrical system with certain values and also to prevent high or excessive current voltage in devices and equipment.

Approval of the earth well of the Ministry of Labor

According to article 22 of the regulations for the protection of electrical installations in the workshops of the Ministry of Labor, according to the importance of the existence of a standard earthing system in all industrial and construction environments, the approval of the well earthing is required. For industries and industrial factories for several years and also from 04/01/2014, approval of ground wells is also required for residential and commercial buildings.

In this section of the regulations, it is stated: (The employer is required to receive annual confirmation of the operation of the earth connection system (earth electrode, devices, connections and other

equipment and accessories) from the Ministry of Labor and Social Affairs.

Only technical protection consultants who have a license in the specialized field of electrical safety from the Supreme Council of Technical Protection and membership in the prestigious association of technical protection consultants and safety services of the Ministry of Cooperative, Labor and Social Welfare can test the ground well. and issue a certificate.

Tiling

In building construction, tiles are thin plates or elements that are used to cover surfaces such as roofs, floors, and walls. Types of tiles and their uses are discussed.

In the current scenario, tiles are a primary element in providing the interior of the building as well as the exterior and beauty. They are mainly made of clay material or any form of mineral raw material.

Today, tiles are also made from recycled materials, which makes this element environmentally friendly. The shape of the tiles is obtained by various processes such as extrusion or pressing at room temperature or any other method.

After molding, they are allowed to dry. These dried elements are exposed to fire. This stage of firing is needed to ensure that they obtain the properties that they are supposed to obtain when they are on the market and in building use.

Different types of tiles used in building construction are available with or without glaze. They are non-combustible in nature. Tiles are ineffective under light.

Floor preparation units

Flooring

The term "flooring" refers to the enclosed lower surface of the spaces inside the building. It may be part of the floor structure, such as the top surface of a concrete slab or floorboards, but it is usually a permanent covering placed over the floor. "Flooring" can also be used to describe the process of laying flooring materials.

The word "floor" typically refers to both the surface and the structure that supports it.

Flooring of the building

The purpose of flooring is to create a surface that can meet the needs of its users optimally, and since different parts of the building are different from each other; Of course, they will be designed and implemented according to their specific conditions. In general, in these details, two types of dealing with floor construction on the ground are presupposed, which are drawn and presented according to the type of ground materials.

Factors affecting the construction of floors on the ground

1. Dryness of the final surface of the floor according to the type of function of the interior space (service floors such as bathrooms, toilets and kitchens are excluded from this rule).
2. Leveling the floor surface by adapting the surface to the desired slope and the absence of height.
3. Being resistant to settling over time.
4. Floor resistance and response to the type of space function.
5. Prevent moisture from entering wet spaces.

Principles governing the formation of flooring details

In response to the above, the principles governing the formation of flooring details can be formulated as follows:

- A) The ground floor (either manual soil or natural soil) is rammed and leveled, depending on the use of the floor, in terms of overall strength of 85-90%.
- b) Often, for the uniformity of the foundation and to prevent the penetration of moisture, at least 25 cm of coarse gravel is placed on the ground and a layer of sand is poured on top of it to fill the empty spaces of the upper part. Part of the floor and about one centimeter on all surfaces. To cover, then the floor is beaten and leveled if needed. In cases where the natural land

has the necessary characteristics, the prediction of drought is omitted.

c) Grade and thickness of floor concrete

Floor concrete with a thickness of 7 to 10 cm and 200 kg of cement per cubic meter of concrete is considered for normal loading and performance (it will be in cases of non-conventional load or special performance of the floor that the calculations and generally decision-making demands itself). In cases where the obstruction does not prevent the penetration of moisture and the characteristics of the floor pavement require a completely dry surface, a waterproofing layer (Girgoni or similar) is used between two layers of floor concrete.

t) In the case of the service floor, which must prevent water penetration from the inside, the concrete surface of the insulated floor is protected by a 2 cm thick layer of cement coating.

ceramic work

Ceramic building materials, often abbreviated as CBM, is a term used in archeology to cover all building materials made from fired clay. It is used specifically, but not exclusively, in relation to Roman building materials. This is a useful and necessary term because, especially when first found in archaeological excavations, it can be difficult to distinguish brick fragments from fragments of roof or floor tiles.

However, ceramic building materials are usually easily distinguished from ceramic pottery pieces due to their rougher finish. Ceramic is a material often used in construction and is made from a mixture of minerals, usually silica sand, with a clay binder and some impurities and up to 30% water. They are fired at a higher temperature than brick, so that the silica recrystallizes to form a glassy material that has greater density, strength, hardness, chemical and frost resistance, and dimensional stability.

Water is removed during baking, although this may be reduced from 30% to 2-5% by drying before baking. In this reduced water

content, depending on the ceramic and process details, the products are molded into a powder before being fired at 1,800-2,000 degrees for days or weeks at a time. Ceramics may have a baked appearance or be glazed (glass-like coating).

These materials are environmentally stable, they do not oxidize further in the atmosphere, so they are economical in terms of maintenance costs. Problems are likely to occur when they are combined with other materials, typically high-pressure and corrosion-prone fasteners. If repairs fail, the consequences can be dramatic. Unlike metals, ceramics are not capable of ductile behavior. They fail brittly directly after their elastic limit.

Plastering

Plastering is one of the primary tasks in building interior design. In order to be able to do any decorative work on the wall and ceiling of the house and building, these surfaces must be plastered. However, building plaster is not a simple skill. But you can also acquire this skill with study and experience. Gypsum is basically a natural substance that exists in nature. Its scientific name is aqueous dicalcium sulfate. This material is in the form of rock when it is extracted from the mine. Then, in the gypsum production factories, by heating the gypsum stone in the furnace, a white powder called gypsum is obtained. Plaster is used in various industries, one of which is the construction industry.

Mixing plaster for plastering

The first step for plastering the building is mixing the plaster. Admittedly, mixing water and plaster seems like a simple task at first. But this process has its own tricks that must be done for proper plastering. You need to add plaster to the water. In this case, you will have more control over the amount of plaster used. To increase the quality of plastering, use fresh water and add plaster slowly. The mixture of water and plaster should be stirred well so that the plaster does not lump and bubbles do not form in the final mixture. You must use the water and plaster mixture quickly. Otherwise, it will

become dry and dead mortar. So if you want to get a lot of chalk, wrap it in plastic.

Plastering with rabbits or without rabbits?

Rabbits are among the structures used in building architecture and are used to create sections and tension on the external surfaces of walls and ceilings. Rabbits can also be used in plastering, and specialists in this field use Rabbits for initial shaping and increasing the strength of parts such as ceilings, columns or walls.

At the same time, using modern materials such as polystyrene, experts have been able to do internal plastering without using rabbits. A topic that only applies to delicate and thin designs. Eliminating rabbits in new designs has led to the emergence of new patterns such as halogen and throat decorations in the field of interior architecture.

The importance of plastering in today's architecture

The importance of plastering in the architecture of buildings and mansions is undeniable. This art has never stayed away from architecture and construction and has always changed over time along with the development of new trends.

Therefore, plastering should be considered an inseparable part of architecture, to which we owe the beauty and appearance of buildings. As this art has been able to pass the time and reach our time despite its long life, plaster works can definitely be seen in the buildings in the future.

Therefore, we suggest that you never underestimate this unique art. Because in a way, we can say that we owe the external and internal beauty of buildings to artists active in this field.

Teaching simple plastering in the building

To plaster the surface, we must first prepare the necessary materials: plaster, trowel, sieve, first we learn the amount of water to pour into the plaster. Divide the container into 4 parts, let's say if we pour half the water, we need to add 4 handfuls of gypsum (two large palms) of men, that is one handful, so here we learn how much gypsum is mixed together.

Then we stir it for 20 seconds (using a mixer, palm or any device to boil it), after 5 minutes we repeat this process, now our plaster mortar will gradually change from liquid to solid. Converted and ready to add to the desired location, remove the plaster with a mortar and smooth the surface. For this work, high speed and experience are required, but for small stains, ordinary people can also do this work. In the next step, sieve the gypsum powder and make it in the same way as before and add a thin layer on the surface with a trowel. Finally, remove the holes and unevenness with plastic tape and polish it.

Plastering techniques

Apart from molding techniques that are prepared using a mold and then using plaster paste, the plaster of the mold is glued to the desired part, plastering is done with various other techniques, the most common type of which is known as stump Kari or plaster is deep. In this technique, the working method is that first plaster paste is drawn on the desired part to prepare the text. After the plaster dries and hardens, the pattern is placed on it and the desired design is cut with a plaster tool.

Employees and plastering execution time

Plastering teams usually include a master plasterer and a trainee plasterer. Sometimes the plastering team may include two plastering masters and one plastering apprentice. The task of the master worker is plastering on the surface of the wall and ceiling and finally troweling the wall, and the task of the apprentice is to plaster in Istanbul containers and also to deliver this made plaster to the master. Craftsmen If the volume of the project is larger, several high-structure plastering teams can be used at the same time. If you want to increase the speed of plastering, you must have a good job and get help from skilled craftsmen. One of the most tangible things is the ceiling plastering project, which requires more time.

Plastering on the surface of Rabbits is one of the things that takes more time. But in general and on average, it can be said that each building plastering team, including expert master craftsman and

plastering apprentice, can plaster and soil with a common height of three meters and an area of about forty square meters, and an area of

about fifty square meters Apply white on the wall of habulaks or clay blocks. But as we mentioned in the previous paragraphs, if the plastering method is used, the speed of work increases significantly. As far as the plastering team can plaster about three hundred square meters of the wall daily.

Suitable weather for building plastering

If you plaster in temperatures below zero degrees, the plaster will freeze and then the plaster will rot. But as you know, this problem has solutions such as insulating the windows and doors of the building until the plastering operation is finished and the plaster dries, as well as using heating devices such as heaters and hot water to make mortar.

Maintenance of plastering of the building

After finishing the white plastering operation of the building, avoid scratching and hitting the plastered surface. For better protection of plastering, it is better to use painting art or wall paper on the desired surface.

Sequential implementation of building plastering operations

Plaster and soil operations are carried out after the following steps:

Porcelain tiles for external and internal walls

Piping of mechanical and electrical installations of the building

Rabbits performance and stepped ceiling

Tiling

Floor Covering

After the completion of the above operations, the white plastering operation of the building is carried out. If you use hemp for the false ceiling, you can do this operation after the white plaster operation. To avoid damage to the electric pipes worked on the floor of the building, do floor construction before whitewashing.

The time for ceramic floors and installation of facades and windows is not very important. That is, you can do it before or after the white

plaster of the building. But be careful that the work of each of the plastering or ceramic work teams does not harm the work of the other team.

The correct and professional method of plastering the building

Try to always use high-quality and standard plasters.

Note that the best plaster for plastering is freshly produced plaster (if properly stored, plaster can be stored and used for up to a year).

Old and wet plaster is not suitable for work. Plaster mortar, which is old, no longer has the adhesion and quality of new plaster.

Use professional teams for the plastering project, teams whose plastering examples you have seen.

Use an experienced plastering team that you have seen work with before. Because unskilled crews, in addition to lowering the quality of work technically, will have a lot of material waste, which is probably covered by their cheaper wages.

The plastered surface of the wall should be completely smooth, polished, perpendicular and free of distortion, which can be tested by placing a rod on the plastered wall.

The plastered ceiling should also be completely level and without waves. The color of the plaster should be completely white after drying. After the plaster is completely dry, it should not sink or be hollow with the pressure of the hand. Avoid plastering at temperatures below zero. After drying, the plastered surface should be completely hard and not white powder. Metal parts such as door and window frames and metal columns and windbreaks should be rustproofed before plastering. Metal columns and wind braces and the parts where the heater pipe is located in the wall should be covered with chicken netting before plastering. In places where two walls with different materials are connected, for example, a clay wall to a brick wall or a concrete wall, chicken wire should also be used to prevent cracks in the plaster due to different expansion and contraction.

Types of plastering services in the building

- Plastering
- whitening
- Plastering on the ceiling and walls
- Plastering the kitchen arch
- Hidden style plastering
- Plastering on all types of rabbits
- Plastering around lamps and chandeliers
- Features of plastering
- Heat and cold insulation
- Fireproofing
- colorability
- Creating smooth surfaces
- Mixing ability with colored powders

The entrance doors of the unit or the installation of anti-theft doors

The door is one of the main parts of buildings. At first glance, what attracts passers-by to the entrance of the house is the design of the door and door. Today, the construction and design of the entrance door has changed a lot. With a glance at the new models and the old models, we can easily understand that the models used in the new doors are richer in appearance and sometimes represent a symbol of the culture and civilization of a region. The types of entrance door models that we see in today's buildings are generally based on modern and contemporary styles. In today's building metal door projects, the entrance door model is designed for buildings with different uses.

Construction and installation of anti-theft door frames

If the anti-theft door is installed in a new building, it is necessary to install a new frame. In this case, first, according to the dimensions of the anti-theft door that you are considering, the door frame is made. Anti-theft door frame is made of iron profile 8x4 or 10x4.

The method of installing the anti-theft door frame is that you must install the door frame before whitewashing. It is also necessary that the insulated frame is rustproof.

If you want to make the door anti-theft, you may be able to install the anti-theft door on the same old frame.

Installation of anti-theft door locks and handles

Anti-theft door lock and handle are installed separately from the door

After purchasing the anti-theft door, you will receive a manual that explains all the steps of installing the anti-theft lock and handle. Most locks are attached with two screws. Then attach a spindle to the handle. After that, it is time to connect the internal lock.

Measure and mark for hinge installation

For this step, it is better to get help from someone. Place the door in the frame. Make sure there is a 3mm gap. Then mark the location of the hinge. You can install the hinge with a 2mm drill bit. Do the same for the bottom and middle hinges.

Anti-theft door installation

There are two common methods for installing an anti-theft door:

1- Installation of anti-theft door with welding

First, remove the current door of your house and replace it with an anti-theft door. Then insert the anti-theft door into the frame from the side that does not have blades.

Fully align the lid and test it. For example, open and close the door a few times to make sure your door is properly aligned and working properly. Then weld a few spots in the marked holes inside the frame to temporarily mount it.

When you are completely sure of your anti-theft door, you can completely weld the door.

2-How to install the anti-theft door using the roll bolt method

Using this method requires that the walls on which you install the door have sufficient resistance. For example, concrete walls have enough resistance to do this method.

To install an anti-theft door using the roll-bolt method, you must first align the door and frame perfectly. Then make sure the door is working properly. Align the door hinges with the wall. Then make holes in the wall according to the frame holes.

Demolish the door and wall again and carefully insert the roll bolts into the marked holes.

Installation of anti-theft door in the separating walls

It is necessary to measure the frame well before installing the anti-theft door frame in the partition walls. Then cover the frame with anti-rust to increase the life of this door. Finally, align the frame completely and then install it.

Aluminum windows and doors

Each type of metal or any material in general has different uses in different industries according to its special properties and characteristics. Aluminum is also used in various industries due to its special properties. But what makes the use of aluminum important in various industries is the unique properties of this valuable metal. Due to its special and different properties, aluminum is widely used in various industries such as aerospace, transportation, automobile manufacturing, packaging industries, electrical industries, construction industries and many other industries and has become one of the consumables of these industries. Is. The figure below shows the consumption of aluminum in different industries separately.

Today, a high percentage of aluminum produced in the world is used in the construction industry. Aluminum in buildings and structures in a wide range of different applications, such as doors and windows, aluminum roofs inside and outside buildings and factories, windows and coated prefabricated aluminum sheets for

the facade of large buildings, shop windows It is used for doors, canopies, architecture. Also, aluminum structures and covers are

used to restore many concrete buildings with a lifespan of more than 50 years, which show signs of destruction and scaling. Such a process prevents further erosion of the building, increases its beauty and, in addition, saves energy due to the insulating property of the aluminum coating.

The light weight of aluminum equipment is considered a very important factor in construction engineering applications. This light weight as well as high malleability make aluminum the purest metal for making windows. Aluminum materials used in the building have a long life and do not require maintenance. Also, the use of aluminum reduces the static load of the building, and as a result, the required materials are also reduced and less pressure is applied to the foundation of the building. Therefore, the foundation of the building can be designed with less materials.

Aluminum stepped ceiling

Another application of aluminum in the construction industry is the production of false ceilings. The need of large construction stores, hotels and hospitals for a calm and beautiful environment, the need for high corrosion-resistant roofs for swimming pools and wet environments has caused aluminum to enter the field of construction in the form of false ceilings.

All kinds of false ceilings with different designs are used in buildings with stone wool layer, which makes these ceilings suitable for insulation. The advantages of the false ceiling include the following: wide range of uses, decorative appearance, acoustic, non-flammable, quick installation, simple and quick access to the equipment behind the ceiling, variety and beauty of color, durability, ability to be installed on the wall, ability Equipped with any type of light, the ability to create a speaker valve and the ability to wash. All these features make this type of roof suitable for use in industrial centers, hospitals, hotels, swimming pools and humid environments, sports halls and even open spaces such as gas station roofs.

Aluminum facades

The facade is an integral part of the building, which in addition to the special beauty of the structure, also makes the appearance of the city more beautiful. The unique features of aluminum have launched a new revolution in architectural and building engineering. Aluminum facades with high hammerability, impressive and extraordinary beauty, variety, design and easy connection have gained many fans today. By choosing the right facade for the building, it is possible to build beautiful structures that are safe and do not pose a risk during accidents such as earthquakes. Aluminum facades are more suitable than other facades for this purpose. In stone facades, there is a risk of stone falling, which is very dangerous. In addition, as the foundation of facades of stone, cement, brick, etc. . . It is located on the external walls of the building, and due to the lack of connection to the structure, the external walls collapse quickly during an earthquake, so the components of such facades are not logical and safe. In addition to lightness, corrosion resistance, the ability to use aluminum in areas with different climates, the ability to paint and produce beautiful and durable structures, this metal has been widely used in buildings. The high strength of this metal, along with its lightness, has made it possible to produce high-altitude displays. The existence of diversity in the system of exclusive aluminum facades makes it possible to choose the best type of system according to the climatic and geophysical conditions of the region and the characteristics of the structure. In addition to the mentioned cases, the use of aluminum in different parts of the building such as heating systems, aluminum radiators, ventilation systems, handles and fittings, fences and guards, stairs, sofas and chairs, lights. It is increasing day by day.

Roof bituminous waterproofing

Today, bituminous waterproofing is considered the most suitable and common insulation for roofs. So that we rarely see a place where insulation other than bituminous waterproofing is used in its roof. bituminous waterproofing on the roof can protect the building well during rain due to its high resistance to moisture and heat. On the other hand, the installation of this type of insulation is much

easier and faster than other roof insulations, and for this reason, it has more fans.

Equipment needed to install roof bituminous waterproofing

Special tools and equipment are needed to install and run bituminous waterproofing on the ceiling or any other surface. Of course, these tools are common in all methods, and some installers may use more diverse equipment.

In general, installers use tools such as liquid gas (capsule), plate flame (single flame or multiple flames), carpet cutting blade trowel, spark lighter, fireproof gloves, rubber blade with handle, broom, flat shoes and so on. . . use.

Bituminous waterproofing for repairing the roof of the building

No matter how high the quality of bituminous waterproofing installation is, after approximately 10 years, this insulation will begin to erode and will no longer perform optimally. In case of improper installation or background factors, this time is less than 10 years. bituminous waterproofing may be damaged or removed due to the placement of heavy or sharp objects, water accumulation, continuous sunlight, sudden temperature changes and other factors.

In this case, the moisture will penetrate inside and you will see that the roof is wet and in more severe cases it will drip. In such a situation, it is necessary to repair the bituminous waterproofing of the roof. bituminous waterproofing repair is usually done in such a way that the damaged layers are repaired. But sometimes it is necessary to separate the old layers and redo the bituminous waterproofing installation process.

Couple of skylights for the rafters

Pre-engineered systems are changing building performance for the better. A trussed roof, or truss, is a pre-engineered A-frame structure that provides strong support and reduced labor costs. They can be installed in one piece. Therefore, they are widely used in building construction.

This type of lampshade is made of polycarbonate or acrylic material and has great strength against scratches and impacts. Also, Kopel skylight ceiling has more exposure than other types and is very suitable for areas that need more ambient light.

One of the great features of this type of roof is that it does not change color after a long period of time. After about 10 years, the Kopel skylight roof will change its color by about 2 percent. For this reason, it does not create disharmony in the beauty of roofs of houses and structures. In fact, the copal skylight ceiling is also called a bubble skylight, which is very popular.

How to install the couple skylight ceiling

To install this roof, you must first create a profile network. It should be noted that this part needs a chassis, and bituminous waterproofing must be used to insulate this part after connecting the foundations. Kopel skylight foundations are made of fiberglass material and are installed on the desired part of the roof. Acrylic or polycarbonate bubbles are also used on this grid as bubble reflectors.

Kopel skylight ceiling is very suitable for spaces that can be seen by neighbors. This coating does not need to be washed a lot and it will look like new with one polishing.

Wooden doors of the units

Wooden doors have been widely used in decoration since the past and the reason is the originality and unique appearance of this type of material. Based on this, the designs and models implemented for these doors are very diverse, and some of them have engravings and carvings on their surface, and some are presented in a simple way. One of the most important factors that should be considered when buying wooden doors is the decoration style and interior design of the desired environment.

In general, if you are looking to buy doors for classic environments, the best choices are doors that have fittings, knots and decorative

carvings on their surface. These doors are available in different colors and are the best choice for classic, brown and hazel houses.

On the other hand, if you intend to buy a wooden door for modern environments, simple designs with matte colors are an ideal option in this field.

In some modern doors, diagonal lines and geometric shapes are also implemented, which have a better effect than simple doors. As a result, you should first consider the other devices in the desired environment and the cabinet, etc., and choose the wooden door based on that.

Buy wooden door based on application

One of the most important factors to consider when buying wooden doors is the place of use and installation. Because the specifications of the doors are different according to the type of use. For example, if the goal is to choose a wooden door for the toilet and bathroom, you should not choose MDF-coated options at all. Because moisture causes the door to swell, and over time, its surface loses its resistance and strength due to decay. In this situation, it is better to choose doors that have a PVC coating so that moisture cannot reduce their lifespan. In order to buy a wooden door for the bedroom, in addition to the quality, because it can be seen from different parts of the house, for this reason, attention should also be paid to their appearance. It is better that the rooms are all selected from the same design to create a good fit in the interior environment.

The color of the wooden door

It doesn't matter if you intend to buy a lobby door or an interior door, in any case, you cannot ignore the effect of painting them on the beauty of the environment. According to the type of application as well as whether the style is modern or classic as well as other features of the installation environment, the best color was finally chosen.

For example, if the interior design of the building is modern and the size of the rooms and the house is small and there is little natural light in them, it is appropriate to buy a light-colored wooden door. Using

dark doors makes the space look smaller and darker, and it is completely opposite in light colors.

Due to the fact that wood has a high coloring ability, for this reason you can finally choose the right option according to the conditions of the environment and your taste and desire. Of course, note that stains and dirt are more visible on light-colored doors, and over time, their original appearance and beauty will be lost.

Types of wooden doors

Wooden doors have been, are and will be in every house for a long time. But with the passage of time, it has changed a lot in terms of appearance. If you remember, in the past, colored or frosted glass frames were very common in wooden doors. But nowadays, the doors that include the engraving of embossed and recessed motifs are beautiful. Of course, depending on the type and style of the door we talked about above, there are many variations. Types of wooden doors include lobby doors, interior doors, entrance doors.

Door size

The doors have standard sizes according to the number of hinges, and this factor is taken into account in the construction of the frame. Therefore, when buying a wooden door, you must provide the exact size to the manufacturer, changing the size of the wooden frame is not only expensive and time-consuming, but in most cases it will not be possible for safety reasons.

Wooden door cover

In addition to the wood used in the body of the door, there is also a great difference in the type of coating and it greatly affects the beauty and durability of the wooden door. Therefore, we suggest that you pay attention to the type and material of the coating before buying wooden doors. PVC, MDF, natural and synthetic coatings are the most common types of coatings for these doors. The best type of coating used in these doors is produced from natural wood and after various steps and contact with water vapor, it is finally installed on the surface of the door. Doors that have a natural coating have a higher price and are completely biodegradable and recyclable. Synthetic coatings are produced with polymer materials, resin, paper and other materials and are installed on the surface of

the door in different ways. Doors with synthetic PVC coatings will be more resistant to moisture and cheaper than natural coatings.

Closets

How much more beautiful it will be when you decorate your bedroom with wardrobes attached to the mirror to breathe the spirit of order into your home.

Construction and installation of VC foundation closet: What is VC foundation? VC foundation is a polymer of polyvinyl chloride, which is considered a type of plastic. To produce PVC, plastic is combined with vinyl. PVC is used for electronics industries and for industries that require piping. In most cases, VC foundation pipes are the most economical and cheapest type of pipe both in terms of initial purchase and installation. VC foundation sheets (with foam) are sheets that have waterproof properties due to their chemical and physical structure, and the waterproofness of these sheets has made them widely used in the decoration industry and kitchen cabinets.

PVC

Where is VC foundation widely used in the decoration industry? With the above explanation, you probably guessed right! Wherever there is a need to have a very moisture-resistant decoration, such as a pool closet, a sink cabinet, a bathroom closet, a laboratory, etc., but the main question is, do they make a complete kitchen cabinet with a VC foundation? Answer: Usually not. Because this material is relatively expensive and on the other hand, it does not have very beautiful colors and designs compared to MDF, high glass and wood. But in recent years, the technology and variety of making VC foundation sheet has progressed. And now it's just a plan. Completely white is not produced. Therefore, you can make a complete cabinet with these colored or patterned VC foundation sheets, and some people make this decision according to their conditions. However, it is still rare that the entire kitchen cabinet doors and body (except around the sink) are made with VC foundation.

It is not possible to determine the exact price of the VC foundation closet or cabinet before designing, determining the implementation details, and asking professional contractors. VC foundation cabinets are usually used for special purposes and the price is relatively high. But the main characteristic of the VC foundation, which is its waterproofness, is so obvious that it has caused its use to increase day by day. On the other hand, the new designs of this material have caused more use of VC foundation in the construction of cabinets, wardrobes and home decoration.

Comparison of PVC and MDF

If we want to have a comparative view of VC foundation and MDF, it can be said that VC foundation will be much ahead of MDF. Because the long life of PVC and its high resistance to temperature, moisture, impact, scratches and acid materials have made it popular among customers in recent years. Of course, one cannot deny the beauty and uniqueness of PVC. Foundation VCs are available in two types, matte and glossy, of course, the glossy type of foundation VCs has been very well received by customers in the past year.

In general, it can be said that the maintenance of VC foundation cabinets is much easier compared to MDF cabinets. In addition to this, the difference in style and style of design and implementation of the VC foundation wardrobe or cabinet compared to the MDF wardrobe or cabinet is one of the points of attracting customers to this new creation.

Construction and installation of PVC closet

Disadvantages of PVC sheet: The only disadvantage of PVC foundation sheets is their indestructibility and damage to the environment.

Choosing a PVC cabinet for the bathroom vanity: Choosing the right bathroom cabinet is considered one of the most essential bathroom and toilet equipment. Bathroom cabinets are made and marketed in different sizes, shapes and materials, and you can buy a suitable model with the desired color and install it in the bathroom

or bathroom according to the decoration style of your bathroom. Toilets are made of different materials such as VC foundation,

natural wood, MDF and metal. The construction and installation of PV Sikamo is the most appropriate choice for the bathroom because this material is resistant to water and moisture and is easy to clean. The PV cabinet has a long service life and does not deteriorate over time.

Cabinet and decor

Cabinet design principles in the building



When it comes to the interior decoration of the house, without a doubt, the design of the kitchen cabinet has a special role in the design space, and paying attention to the principles of design and compliance with the standards of the kitchen cabinet can make the work result very satisfactory, and in the stage of the cabinet implementation, it saves money. to prevent many problems caused by implementation and rework and waste of consumable materials, interior decoration design and especially the design of home cabinets has always been the attention of contractors and owners of residential houses and paying attention to color scheme, implementation points, placement of kitchen facilities, dimensions And the height of the cabinets, the location of the equipment and the hood, gas, microwave oven, washing machine and dishwasher, and most importantly, the cost of running the cabinet are the things that can determine the result of the design work and increase the level of customer satisfaction in this issue.

Types of kitchen cabinets:

In general, cabinets can be classified into the following groups in terms of type and material used.

1. Metal cabinets (these cabinets are made of galvanized sheet that is painted and made in different types, the consumption of these cabinets has decreased over time with the appearance of MDF cabinets)
2. Normal mdf cabinets, which have a wide variety of colors and top designs, and have a reasonable price compared to other mdf cabinets.
3. High-glass cabinets, which have more quality and elegance than ordinary mdf cabinets, and as the name suggests, have a shiny melamine coating.
4. Vacuum cabinets, the cover of which is vacuumed and pressed by special machines on the mdf surface after performing cnc operations on the cabinet body and creating beautiful and prominent designs on it, and the final product is assembled and assembled in the building.
5. Wooden cabinets that are made from all types of wood available in the market and in terms of the use of wood material, which can have many variations depending on the type of wood used in its construction. It is more expensive and more luxurious than other types of cabinets, and it is more durable than other models.

Stair stonework

The stone work of the staircase is done in the last stages of construction. Because the stairs are places of passage and if their stone work is done earlier, carrying materials over them will cause hard and dirty stains on the stones of the stairs.

What are the stages of stonework for the staircase?

1. Work sink next to the stairs

The first step in the stone work of the staircase is the implementation of stone next to the staircase. This work should be done before the stone work of other parts of the staircase. Because the stone is placed next to the stairs, it becomes

difficult to implement it at a time other than the start of the work, and it is not possible to plaster behind it.

What is a stepping stone? The stones that are next to the stairs are called walls, as in the previous picture. These stones have a small width and are placed on the wall next to the stairs as well as the foundations (where the rows of stairs meet). The side stone of the staircase is behind the front and bottom stones of the staircase.

2. Stonework in front of the stairs

In the second step, we place the stone in front of the stairs. Then, as in the picture below, we prevent it from tilting or falling with wooden boards or a heavy object such as a brick. Then we fill the back of it with special mortar or pieces of construction waste, which is not recommended.

3. Stone work on the floor of the stairs

At this stage, we must place the stone of the bottom of the stairs in a level and perpendicular manner on the stone in front of the stairs. For this, we must first make the place of floor stone smooth and uniform with cement mortar. Then place the stone on it so that it sticks.

4. Covering the stair ramp

The stair ramp is the part where the stepping stones are placed. In the last step, we plaster the lower part and the sides of the ramp of the staircase which is visible. For more beauty of the staircase ramp, you can use prefabricated gypsum panels or the stone itself for this purpose.

Why is it better to use stone for the staircase wall?

The wall of the staircase is one of those parts of the building that gets a lot of damage during moving. Because of this, plastering and its colors are scratched and damaged. Now, if we use a stone with high resistance for this purpose, there is no need to plaster or permanently paint the walls of the staircase.

What is the method of stoning the staircase wall?

- 1- The method of implementing internal walls
- 2-The method of implementing external walls

What characteristics should the stepping stone have?

The stones used in the stonework of the staircase must have the following characteristics:

1. High resistance

They must have a high resistance to impact and wear. Because the stones of the staircase are constantly exposed to traffic, pressure and impact. Therefore, if they do not have the mentioned features, they will suffer from cracks, breaks and wear.

2. Low porosity

They should have less pores so that they don't get water and get damaged during washing.

3. Easy maintenance

They are easy to maintain and stain less easily. Because these types of stones are constantly exposed to pollution and dirt. As a result, stones that are easier to clean are more suitable.

4. No corrosion

Stairway stone and any other type of stone must have high resistance to chemicals and detergents. In this case, they will be less damaged by washing and staining, and less corrosion will occur on their surface.

What characteristics should the stones of the staircase wall have?

In general, the stones used for interior walls and staircase walls should have the following characteristics:

Beautiful appearance:

These types of stones must have a beautiful and polished appearance because they are constantly in our sight.

Flat surface:

It is also better to have a smooth and polished surface so that they are not damaged due to water and detergent remaining inside their holes during washing.

Insulation:

These types of stones should be good insulation against heat and cold. Because they are used to cover the walls and can prevent the wastage of energy in indoor spaces.

Good price:

The stones used for stone work on the walls of internal staircases should have a more economical price than the stone of the facade of the building and external walls so that the final cost of the work is not high. Because the stone wall of the internal staircase is less exposed to atmospheric factors than the stone of the outer wall of the building. So we can use cheaper stones for this. But you can spend a little more for the masonry of the external staircase wall of the building.

Stair railing welding

Welding is a common method of joining all kinds of metals, you need a welder in all parts of the building, from the frame of the building to the delicate work (such as installing and welding railings and stairs). The fence is very effective in increasing the security factor of public and private places, and you rarely see a building that does not use a fence to protect the lives of the residents. Considering that the fences guarantee the safety of the residents, their implementation is very important. It is better to use skilled operators to install the fence.

Welding skills

The skill of the welder is one of the most influential factors in the wages of welding fences and stairs. It is better to follow up your project under the supervision of reliable people and companies so that your work is done in the best possible way.

welding type

There are different types of welding, the most important of which are: oxygen gas welding, resistance welding, electric arc welding (normal) and solid state welding. Electric arc welding has a lower price than other models.

Weight of parts that need to be welded

Many welders weigh the metals before joining them together and are paid per kilogram of iron weight. For example, a metal structure welder receives 400 tomans per kilo.

Fondationlot mosaic and yard

Mosaic is one of the most important and main building materials used in many places and levels where you can see the use of different types of mosaic in spaces such as roof gardens, courtyards, parking lots, yards, etc. For a long time, many people have been interested in covering the floor of the yard, and today you can find the best and most stylish types of these products in many stores.

Types of yard mosaics

As mentioned in the previous section, nowadays many people are looking for the best quality and ideal patio mosaic to cover the floor of their home yard. Of course, we assume that before buying and registering your desired order, you should obtain a series of information you need about the types of these structures and building materials. Each type of patio mosaic has specific characteristics and specifications, and the buyers of these products can prepare and buy the best of these materials by studying and carefully examining each type of patio mosaic. Among the most

important and best-selling types of backyard mosaics, the following can be mentioned:

- Cement yard mosaic
- Granite yard mosaic
- Grooved yard mosaic
- Washed yard mosaic
- Polymer yard mosaic

Cement courtyard mosaic:

One of the best and most unique types of patio mosaic is the cement patio mosaic, which is made of materials such as water, stone powder, and cement, and you will not find any kind of stone in this mosaic. You don't see the yard. The surface of cement patio mosaic becomes very slippery during rain and snow, and if you like to use these products on the floor of your yard, you should pay special attention to this point. Many people believe that using cement patio mosaic is suitable for parking and closed spaces.

Granite yard mosaic:

Granite yard mosaic is one of the most unique and popular types of home yard mosaic, which is made of coarse and fine grains of sand. The field related to the granite home yard mosaic consists of many different colors, the most popular of which are red, lemon, white, etc., and the cement used in the design of these products has different colors. The appearance of the granite mosaic of the home yard is very similar to the granite stone, and many people know this model of mosaic by the name of granite mosaic.

Grooved yard mosaic:

Among the other best and most popular types of yard mosaics is the grooved house yard mosaic, which does not have a smooth surface and has a series of important and original grooves. The grooves on the surface of the mosaic of the home yard have many different designs, each of which has a unique beauty. You can also see the use of different aggregates in this yard mosaic model, which has given these products a unique charm and resistance.

Washed yard mosaic:

Washed yard mosaic with the same concrete wash is another of the best yard mosaic models that many people like to use in their roof

gardens. The mosaic stones of the yard have been washed and protruded, which has given these products a wonderful beauty, and you will not see any slippery surface during rain and snow. This model of mosaics is washed with cement steam after going through the pressing process and it looks like this.

Polymer yard mosaic:

One of the newest and most modern types of yard mosaic is related to the polymer yard mosaic, which is made from various raw materials such as PP fibers, polymer, concrete lubricants, mineral colors and water. The resistance of polymer backyard mosaics is very high and you can easily prepare and use the best design and model for these mosaics. Of course, consider that the price of this backyard mosaic model is a little more expensive than other available mosaics.

Carcass yard mosaic:

It is a type of mosaic that is made from a combination of building materials such as stone and rubble. The surface of this mosaic is smooth and without protrusions. In addition to simple mosaic, you can make a very beautiful combination of carcass mosaic. The size of the rubble can be changed according to the size of the mosaic. Usually, the size of the carcass that is used as a yard mosaic is 40x40.

Painting and wallpaper

Painting the interior of the building can give a new spirit to your home decoration. The most important step to have a successful painting is to prepare the walls and the related space. The implementation of this work is done in several steps. Although not all walls in a room may need to go through all of these steps, it is recommended that you paint the room after checking them all. These steps are done in seven steps, which include cleaning the room, repairing wall cracks, removing mold on the wall, sanding the walls, cleaning the walls before painting and applying primer.

First step: Clean the room

For this, you must first move the furniture and items in the room to another space. Large items that cannot be moved should be placed in the center of the room so that they are as far away from the walls as possible. If a device is placed in the room to protect it, its surface should be covered with plastic or old sheets.

Then, you should remove all decorative items, hangers, curtains, chandeliers and similar items from the walls and move them to another space. It is recommended to put the reusable plates and nuts or nails in a plastic bag to use them again after the painting is finished. It is also better to open the electrical keyboards and their related switches and sockets and hold them until they are reconnected.

Then parts of the room such as the edges of the windows and doors as well as all the cornices should be covered with a suitable adhesive coating. These coatings are different from conventional adhesives and coatings because they are specifically designed to be easily removed from the wall after painting. A clean knife can be used to firmly stick these covers. The entire surface of the windows can even be covered with plastic paper or similar coverings to protect against accidental splashes of paint on the glass. It is better to remove these coatings from the surfaces as soon as possible after finishing the paint and avoid drying them next to the paint.

At the end, large cloths should be spread on the floor and the floor of the room to cover the entire floor and corners of the room. To create a stronger protective layer, you can fold the fabric in half before spreading. If the painting project also includes painting the ceiling, this step should be done more carefully, because it is certain that paint drops will fall on the floor.

Second step: repairing the cracks in the wall

Walls can be damaged in many ways, from cracks and holes to large holes. Each problem has a different solution, which largely depends on the extent of the damage. This section provides instructions for solving different types of problems.

A: Repair small cracks on the wall

Small holes are usually made by nails or screws and are very quick and easy to repair. If the cracks are too small, you can use aquarium glue to repair them. For this, a small amount of aquarium glue should be removed and with the help of a pre-moistened finger, smooth the desired area. But to repair small cracks that cannot be repaired with aquarium glue, you should use a small putty spatula and speckle paste. Then spread a small amount of dough on the hole with a spatula. It should be noted that you should not put a large amount of dough on the spatula, because usually a pea-sized dough is enough for this volume of spaces.

In the next step, the surface of the dough should be smoothed with a spatula. The purpose of this work is to fill and integrate as much of the empty space on the wall as possible. Then, using a damp cloth, remove the excess paste that may have remained on the wall and around the gap. At the end, time should be considered for the paste to dry and then paint the stain if necessary. Sometimes the gap is so small that repainting is not necessary.

B: Repairing wall cracks the size of a ping pong ball

Repairing a crack the size of a ping-pong ball requires tools such as fiberglass mesh tape, filler, a 4-inch putty knife, and 220-grit sandpaper. To start the work, first you need to stick the fiberglass mesh tape on the hole, then fill the empty spaces around the patch with filler and putty. In the next step, you must wait at least 24 hours for the putty to dry on the crack. After drying, the stains should be smoothed with 220 sandpaper. This work should be continued until the border between the gap and the wall disappears. For better results, it is recommended to paint the repaired parts with a suitable primer. For this, a small brush should be used and a primer layer should be applied only on the repaired cracks and crevices.

C: Repairing large cracks in drywall

To repair this type of damage, a spatula, repair plates, sandpaper, knife and filler or putty are needed. If the gap is large, wall repair panels should be used. For this, cuts should be made on the wall in the center of the damaged area so that the repair panel can be installed on it. Then you need to cut a plate to the size of the gap on the wall and then attach it to the wall with the help of screws. In the next step, putty or filler should be used around the seams of the screen. At this time, fiberglass mesh strips should be used and cover the entire area. Then put a layer of putty on it and let it dry overnight. After drying, you should use 220 grit sandpaper and completely smooth the surface of the putty.

It should be noted that one of the problems of using patches is the mismatch of the texture of the patch with the main wall. Therefore, to solve this problem, thin plaster surfaces should be used and a lining layer should be placed on it. After that, the whole wall should be covered with a second layer of lining

D: Repairing large cracks on plaster walls

To perform this repair, you need plaster glue, trowel and putty, screws and sandpaper. To do this, first spread it with the edge of the spatula so that the desired fillings can easily enter that part and fill it well with one hand. At this stage, a knife or trowel should be used to completely fill around the crack, but before filling any part of the wall, you should first remove the loose paint or plaster from around the crack so that you can mark the entire damaged area. Then, if needed, plaster stain can be riveted on the damaged area.

In the next step, the area around the damaged area should be washed with a small brush. For this, a small toothbrush or toothbrush should be moistened with water, and the edges of the gap that will be placed on the wall should be prepared and moistened for filling. With this, the filler dries completely slowly, and as a result, it is prevented from creasing and flaking.

Then the filler should be placed on the gap using a spatula. To do this, you must first put the right amount of the desired material

on the putty spatula and apply the filling material on the crack by pressing its blade on the place. It should be noted that it is better to cover the surface as evenly as possible by only moving the blade in one direction. Excess putty should be removed from the wall to avoid an uneven surface when drying.

After this time, time should be given for the filler to dry. Then you need to use sandpaper to smooth its surface. The sandpaper should be applied well on the surface to remove the excess putty and make the wall surface smooth and uniform. For better results, it is recommended to paint the repaired parts with a suitable primer. For this, a small brush should be used and a primer layer should be applied only on the repaired cracks and crevices.

Third step: repairing the cracks in the wall

A: repairing cracks in drywall

Putty should be used for this, using pre-made putty is a better option for less experienced people and beginners. Then a V-shaped gap should be created along the crack, which will help the putty to last. The dimensions of this gap should be about 3 to 6.5 mm. Then, with the help of a vacuum cleaner, any dust in the cracks should be removed. In the next step, layers of putty should be placed on the crack. A 7 or 10 cm spatula can be used for this. After applying each layer, you need to give it time to dry. Depending on the type of putty, this time can last from 45 minutes to 24 hours. If the cracks are deeper than 6.5 mm, you may need to use mesh tape or paper tape before the putty dries. in such a way that he pressed it to the first layer until it was completely hardened. It is recommended that the layers be thin so that the texture of the putty and the wall becomes uniform as soon as possible.

After the putty dries, it should be sanded so that its surface is smooth and uniform. A dust mask should always be worn to prevent inhalation of particles. 80 grit sandpaper can remove larger burrs while 120 grit sandpaper can be used for fine finishing work. For a better result, it is recommended to sand it well after drying each layer so that the final surface is

completely uniform. At the end, a layer of primer should be placed on the crack so that after the painting is finished, the repaired part will not be different from other parts of the wall.

B: repairing cracks in plaster walls

In this type of walls, the first step is to check the surface of the crack. To do this, first you need to press gently on the wall near the crack. If this pressure is easily done or the wall bends, the plaster surface is probably separated or moved and cannot be fixed with simple repairs, and an expert should be consulted. But otherwise you can follow the steps below. If the width of the crack is less than 6.5 mm, it should be slightly enlarged using a spatula. Although this makes the crack larger, it allows the putty and filler to fit better. Then a layer of putty should be applied to the crack. This can be done with a 10 cm spatula. It is better to apply this putty in thin layers on the cracks. Then a layer of fiberglass mesh tape should be placed over the wet putty and firmly adhered to it. The strips can be cut to desired size with scissors. This prevents the growth and enlargement of the crack.

Then you need to give it time to dry. It is recommended that the room temperature be between 13 and 21 degrees Celsius for the crack to dry completely. To have a uniform surface, it is better to use three layers of putty on the crack. It should be noted that time should be allowed to dry after applying each layer. It should also be noted that each new layer should extend between five and eight centimeters beyond the edges of the previous layer so that the last layer is about 30 cm larger than the original surface.

For this, the spatula should be held at an angle of 70 degrees and moved from the center of the crack to the outside so that the pressure is more towards the outer parts of the crack. It is also better to smooth each layer with a fine sandpaper to remove the bumps between the layers. After finishing the work, it is better to wait 24 hours for the putty to dry completely and then put a layer of primer on it if needed.

C: repairing cracks in concrete walls

In this type of walls, the crack must first be enlarged with a pen and hammer so that the bottom of the edges of the crack is about 2.5 cm larger. This area provides the necessary and more surface for putting putty.

Then you should clean the area around the crack well with a wire brush or a vacuum cleaner or a screwdriver. In the next step, some concrete glue should be applied on the crack, which helps the putty material stick to the concrete. Then you need to apply several layers of concrete putty on the crack with a spatula and press each layer into the crack. You have to repeat this until the crack is completely filled and then give it time to dry. But before drying, to make the texture of the patch uniform with the texture of the rest of the wall, you should use a tool like a broom and roughen the surface of the putty a little so that the difference between the two parts is not obvious.

Step four: remove the mold on the walls

It does not matter which of the walls of the house is chosen for painting, the important thing is that all the molds on the wall should be removed. If the paint gets on the wall mold, it will be more difficult to maintain and clean it in the future. In addition to creating an unpleasant appearance on the wall, molds can also be harmful to health. Fortunately, it is possible to remove mold from the wall with the tools available at home and it is easy to do, which is explained in detail below.

The first step is to combine bleach and water in a large bucket. This mixture should consist of three parts water and one part bleach. First, you should pour the bleach into the container and add the required water to mix the solution evenly. Be sure to wear plastic gloves, safety glasses, and a mask when working with bleach, as bleach may irritate the lungs.

To proceed, you need to use a brush and dip it in the bleach solution and clean the walls with it. It is better if the bristles of the brush are firm and durable. Molds can be removed by applying pressure in

circular motions. This should be continued until the traces of mold are completely removed, but if the desired result is not achieved, the bleach should be allowed to remain on the wall for a few minutes before attempting to remove it.

Then the wall should be air-dried. This maximizes the time the wall is in contact with the bleach. In fact, the wall rests with bleach for a while. But if the wall is very wet, some excess water should be removed with a disposable tissue. It may take several hours for the wall to dry completely, which depends on the humidity and temperature of the environment inside and outside the house. The cleaning process should be repeated until all stains are completely removed. The wall will be free of any mold only when the signs and stains related to it disappear.

Fifth step: Grinding the walls

At this stage, the walls should be smoothed using 80 grit sandpaper or sand stone pad. In fact, this will make the walls have a rougher texture and the paint will stick to them better. For this, you should use circular movements and gently sand all the walls to be painted. It is best to sand all areas as thoroughly as possible. Then you should carefully check the bumps or uneven textures by touching the wall. By doing this, it is possible to determine well whether all the surfaces are uniform or not. It is recommended to leave enough time for this step so that a completely uniform surface can be reached. After finishing this step, all the surfaces from the ceiling to the floor should be cleaned with a vacuum cleaner to remove the dust created from the sanding step from the wall. At the end, the walls should be cleaned with a damp cloth. This should be done several times to remove the last remnants of dust stuck to the walls.

Sixth step: Clean the walls before painting

This step is the most important step for preparing the walls. In this regard, dirt and dust on the walls should be cleaned with a clean dry cloth. In the next step, it can be said that most walls can be cleaned with a sponge and a bucket of warm water. But walls like the kitchen wall need more time because these walls are oily and dirty. To clean them, you must use appropriate detergents. After that, the

walls should be cleaned with clean water from any detergents. At the last stage, the walls are cleaned with a wet cloth.

But another way to clean walls is to mix two gallons of water with one or two cups of white vinegar and half a tablespoon of detergent. Then he cleaned the walls from top to bottom with a clean sponge or cloth and the solution obtained. It should be noted that detergent or anti-grease liquid can be used in the above solution to remove dirt and stains. It is recommended to use a dry and clean cloth to completely remove the stains.

Choosing wallpaper and affecting factors

Choosing wallpaper is an important issue for people who want to use this beautiful and decorative element in their home, and they should choose the desired wallpaper according to some points.

Wallpaper is a kind of decorative covering for the surface of the walls of the building and gives a beautiful effect to the space of the building. The use of wall paper has been of interest to many people and interior designers for years, and many people are interested in using it in interior design.

Today, there are different types of wallpaper and it provides the possibility for customers to choose the right sample according to their budget and taste.

In the market, there are various wallpapers with different designs, colors and materials, which match the interior decoration of the houses in terms of beauty.

building painting

Preparation of walls covered with wallpaper

Professional painters and interior designers always recommend to paint walls that are covered with wallpaper, to completely remove the wallpaper from the wall and apply the paint to the raw wall. But this work is always accompanied by difficulties. Therefore, if it is not possible to separate the wallpaper from the surface, by considering

the methods, the color can be applied to the wallpaper. In this part, the method of separating the wallpaper from the wall,

separating the borders made with wallpaper and finally separating the wallpaper from the drywall is presented.

a) Removing wallpaper and preparing the wall

Removing wallpaper can be a lengthy process, but it's not impossible. This can be done in a number of ways, including removing full-length wallpaper, removing wallpaper edges, and removing wallpaper from drywall.

The first mode: separating the wallpaper throughout

Depending on the type of wallpaper used for the walls, such as waterproof paper, this may take longer. After finishing the work, the glue under the wallpaper should also be cleaned. At the end, the walls can be prepared to start the painting process.

First step: room preparation:

Before starting the work, the room should be prepared so that the items in it are not damaged in any way. At this stage, all decorative items and furniture should be removed from the room where the project is to be carried out. Since there is always a gap between the wallpaper and the corresponding walls, a lot of dust is released during the removal, so it is better to empty the room before starting the work, so that there is no need for subsequent cleaning. Meanwhile, if the furniture is too heavy to move, they can be completely covered with plastic sheets.

Then all excess must be removed from the wall. Lamps, socket caps, vents and anything else attached to the wall should be removed. A screwdriver should be used for this, and all screws and hardware should be placed in a reusable plastic bag so that they are available after the job is done. Sometimes areas under light fixtures are the best place to start peeling wallpaper.

In the next step, the floor of the room should be well covered using a plastic cover. Be sure to cover the baseboards as well,

as these areas may be subject to damage when water splashes onto the wall. In the end, it should be noted that the electrical

switches must be turned off, because it is very dangerous for water to enter the electrical switches and sockets.

Second step: Peeling, spraying and scraping wallpaper:

At this stage, the material of the wallpaper should be checked. In some cases, wallpaper can be easily removed from the wall without the need for additional products. A spatula or putty spatula can be used to loosen the edge of the wallpaper. If the wallpaper is removed without leaving a mark on the wall, the material is stretchable. But if any trace of adhesive remains on the wall, water should be used to complete the removal process. Of course, hot water and steam should be used to remove some stubborn wallpapers.

Then you should start to peel off the wallpaper from the corner or side of the keyboard. If necessary, a putty knife or spatula can be used to separate the wallpaper from the wall. But you should be careful not to damage the plaster or part of the wall and remove the wallpaper by hand as much as possible. In theory, removing the top layer of wallpaper will make the underlying layers absorb water better and the removal process will be easier.

But sometimes, some wallpapers may be stuck to the wall with strong glue, in this case, if the wallpaper is not removed from the wall by performing the above tasks, it is necessary to make many holes on its surface with the relevant tools so that the water can enter, penetrate into it. It gets easier. This step is very useful for waterproof or glossy wallpaper or vinyl. It should be noted that if the top layer of wallpaper is removable, there is no need to worry about removing the back layer.

Next, a clean spray bottle or tank should be filled with hot water. Spraying allows you to wet a larger area more quickly, but soaking a sponge in a bowl of warm water will help the water fully penetrate the layers underneath, so it's up to you. but in any case, the hotter the water, the more effective it will be in removing the wallpaper. Of course, in some cases, you

can also use warm water and white vinegar in a ratio of one to one for this step.

Then, using the selected tool, moisten the desired surface well to make it soft. If there are still parts of the wallpaper on the wall that cannot be removed, it is not a problem, but it should be noted that those parts are also sprayed. Any area that is removed with a nail or putty spatula is said to be well softened. The point that should be noted at this stage is that if the desired wall is plaster, it can be moistened as much as desired, but if the wall is dry, only the amount of water should be used, because moistening for more than fifteen Minutes can cause permanent damage to these walls.

After softening the remnants of the wallpaper, a putty spatula should be used to scrape it and its supports. For this, the spatula should be held at an angle of 45 degrees so as not to scratch the wall. The more flexible the trowel used, the less likely it is to damage the wall. If there is another layer of wallpaper under the first layer, you should just focus on removing the top layer before you think about the second layer. If the first layer is completely removed, the underlying layer is much easier to see and remove.

This step must be repeated several times to completely remove the remnants of the wallpaper, because any part of the wallpaper that remains on the wall will be visible under the new layer of paint. In addition, the wallpaper must be completely removed to clean the adhesive underneath. At this time, it is not a problem to walk away from the project and rest because no chemicals are used and as a result no part of the wall is damaged.

Step three: Remove the wallpaper glue

At this stage, the glue should be removed as much as possible with a putty spatula. You can also spray some hot water on the glue and then use a spatula or knife. Under the wallpaper, there is usually a layer of glue that was originally used to place the wallpaper. If this adhesive cannot be completely

removed, it may cause the fresh paint to crack, bubble, and separate layers of paint.

If the wall is still sticky at the end of the work, it means that there is some glue left on it and this step should be repeated. You can also use special glue solvents and spray on the remaining glue and remove it with a putty spatula after ten to fifteen minutes. Of course, since these substances are chemicals and can be harmful to human health, you can use warm water and white vinegar in a ratio of one to one, or hot water and baking soda in a ratio of one liter to one tablespoon. In each of the above methods, it is recommended to use special gloves to minimize the amount of damage to the skin. It is also recommended to do this step in small dimensions, such as two meters by two meters, so that before the wall dries, the adhesives can be completely removed with the help of a trowel.

After the glue is completely removed from the surface of the wall, you should put the sponge in a container containing clean and warm water and then press it to remove the excess water and moisten it. Then the walls should be cleaned from top to bottom. After this, you need to give it time to dry. In this interval, the surface of the wall can be checked again to ensure that the glue is completely removed.

Fourth step: repairing and preparing the wall

After performing the previous steps, you must wait at least twelve hours for the wall to dry completely. Then, for the final round, the complete removal of the wallpaper and its glue should be checked completely. Then, using putty, the defects of the wall should be corrected. Then, to completely smooth the wall, its surface should be completely sanded.

Installation of windows and doors

Glass cutting is done using tools with a diamond blade. Also, according to the type of door and window, lining or plastic or rubber strips are used to install the glass. which we will discuss further.

For wood and metal frames that have slats, the slats must be removable and re-installable. The distance of the automatic screws used for these fences is about 20 cm.

For doors and windows that use plastic tape to install their glass, care must be taken when cutting the glass to the space required for these rubber strips. For wooden or metal frames that are not used at the same time as the glass is installed, care should be taken to use a sufficient amount of lining. In the case of this type of glass, the liner is made in the form of a triangle with one centimeter foundations on the edges. If one-sided patterned glass is used, the patterned surface of the glass is placed outside the environment to have a better view and prevent permanent contamination of the glass.

Drilling and grinding construction glass

Drilling and grinding construction glass As we said, tools with a diamond blade are used to cut construction glass. They also use diamond drills to drill holes in the glass. Alignment or grinding of glass is generally done at the edge of the glass. So that the edge of the glass is not sharp and does not cause cuts or inconvenience to consumers. This work is done by diamond grinding machines in factories and workshops.

Glass cleaning

When cleaning the glass, be careful not to damage the glass surface, lining and window frame. All parts of the glass, including the corners of the door and window frames, the corners and edges of the glass, etc., must be cleaned. If you spilled paint on the glass while painting, it is better to use thinner. Strictly avoid using chemicals that are not approved by the monitoring device.

Installation of sanitary faucets

Installation of faucets is different depending on which part of the building the faucet belongs to. To install the built-in valves, the chassis and the core of the built-in valves must be installed before construction, and then the external part of the valve must be installed after tiling.

In terms of installation, there are two types of faucets:

wall-mounted or in a bowl

Bathroom and toilet faucets are wall-mounted. Dishwasher and sink faucets are also types of faucets that install in a bowl. Of course, wall faucets may be used to install sink faucets and dishwasher faucets in surface plumbing.

Faucets are a device for connecting and disconnecting and controlling water, which in addition to our convenience will save water consumption.

In the early years, the faucets were installed only for their main purpose, but in recent years, in addition to disconnecting and connecting and controlling, their beauty and appearance have also become important priorities.

This feature should be sufficiently involved in the structure of the valve so that its main purpose, which is the control function of valves, is not questioned.

Another thing that should not be forgotten is the use of standard material, which, in addition to increasing the life of the faucets, makes the faucets more hygienic.

Lead and zinc, which is an alloy of lead, is one of the most dangerous materials that may be used in chelates.

Purchase of sanitary facilities of the building

The duty of hot and cold faucets is to connect and disconnect and control the amount of water and their mixture. In fact, the main task of faucets is to distribute hot and cold water properly. It should be noted that faucets in the kitchen or bathroom play an important role in beauty. Faucets are consumers that are installed at the end of water piping. Sanitary and construction faucets perform the work of connecting and disconnecting and controlling the flow of water and the combination of hot and cold water. Fortunately, you can put your mind at ease by buying standard Iranian faucets. With the advancement of technology in the last few decades, various and new faucets are introduced to the market every year. In the past,

faucets were measured in terms of quality and efficiency, but nowadays it has shown its position as a factor for beautifying the

interior decoration of homes. Therefore, it is better to install standard faucets and sanitary ware.

The most important factor when installing faucets and sanitary ware after fixing and sealing the parts is installation in the right place, right angle, height and exact distance. Mixed faucets are so called because they mix cold and hot water and are adjusted by the consumer.

Installing the mixing faucet

These days, almost one mixed faucet including four mixed faucets, shower, sink, laundry faucet, and toilet faucet is installed and used in every house. In some places, such as the roof, living room and parking lot, only one cold and hot water tap is installed and used alone.

In the past, only classic mixed or screw taps with different qualities were produced and marketed. These types of valves are sealed by a fixed brass piece called the left round and a movable brass nut equipped with a rubber gasket. Deposition and corrosion around the left side and loss of the rubber gasket are considered to be the causes of water dripping from old valves and the main weakness of these types of valves.

These valves have a lower price than lever valves and have a simple and ordinary appearance.

Installation of wall faucets

To install wall faucets in the bathroom and toilet, you need two flanges or corrugated connectors, which are usually included in the package of the faucet. One number is for cold water and one is for hot water pipe installation. Langi is one of the angle seams that are threaded from both sides. To install the valve, first we completely close a stem with Teflon tape. Depending on the Teflon tape used, 10 to 18 turns of Teflon tape are sufficient. With the other head, we do another kneeling.

After this, the faucet installer must install the lag on the plumbing on the wall. For hot and cold water pipes, each pipe is unique.

Usually, the right pipe is installed for cold water and the left pipe for hot water. Make sure the valve and piping are tightly closed.

After that, install the valve caps which are used to cover and beautify the valve. Place the 3/4-inch washer on the valve and place the valve on the valve, using a wrench, wrench, or locking pliers to fully attach it to the flange.

Installation of lever faucet

However, with the advancement of technology in all fields and the production of lever faucets cartridges, the model and method of manufacturing sanitary faucet made a great revolution, and lever-mixed valve was produced for the market. Currently, more than thousands of models with different handles, levers and trunks have been designed and produced. The cartridge or core of lever valves also have many sizes and variations in their shape and function, which are made and produced depending on the design of the faucet mold. Of course, in Iran, unfortunately, due to production problems, no company has produced lever faucet cartridges or nozzles, and all domestic valve brands and companies use foreign cartridges, which are mostly Chinese. In general, the mixer tap is installed on the wall or on the bowl in two ways

Installing a shower faucet

In general, the shower and toilet faucets are installed on the wall and by connections such as hinges to the plumbing connections, or they will be installed on the sink and sink. Wall faucets are fed directly from hot and cold water pipes. The distance between hot and cold faucets or the so-called axis is 153 mm, which is more or less the same in all lever and non-lever valves.

Tokase or single foundation faucets are connected to hot and cold urinal faucets by single leg m10, m8 or other size hoses, and their inlet water is connected and controlled by the urinal valve. Washing machine, dishwasher and refrigerator faucets are among the most used faucets in the building.

In some houses, wall faucets are also used for sinks and dishwashers. After installing various faucets, depending on the type

of faucet, their accessories must also be installed and sealed. In the toilet faucet, a solar hose will be installed on the fixed shower head or the moving head of Unica University.

The shower should be installed so that people do not need to bend down to use it. The height of about 175 to 195 can create a suitable distance between the shawl and the head. Of course, the height of the movable shower head is adjustable.

Installing the dishwasher lever faucets

Sink faucets and dishwasher sinks have the same science, which is mostly the science of fixed sink faucets and the science of movable dishwasher faucets. It is a type of lever faucet for washing dishes of the hose type, which is known as a shower.

When installing the sink faucet, we first install the hot and cold water hoses on the faucet, and then install the retaining nut or screw and the bottom of the faucet to tighten it on the sink or sink.

There are two types of valve holders, either with a nut that tightens from under the valve and holds the valve, or with a single screw or double screw sole.

Single stem valve hoses come in several different sizes. The hoses that are connected to the valve itself are usually 10m or 8m. From the side of the urethra, the beads are 3/8 or 1/2 inch.

Faucet installation

Installing the sink faucet is done like a sink faucet that has a single foundation. Before installing the hose on the valve, make sure the size of the foundation valve and their compatibility with your hose. Piswar hoses are sealed by foundation valve washers and do not need teflon. If the urinal hoses are short, you can use adapter hoses of the same size to extend the length of the used hose.

Installing a toilet faucets

Installing a toilet faucet is like a wall faucet in a bathroom shower. The distance between two faucet inlets or faucet axis is 153 mm as

a standard. Install the Iranian toilet faucet at a height of 60 cm. Installing the toilet faucet is about 80 cm. Of course, these works

should be done during the piping and according to the flooring and the finished height from the floor.

How to install a faucet

Like faucets with an electronic eye that are used in bathroom faucets, a cartridge or electric valve is used in the structure of the valve and is powered by a battery.

Built-in faucets are also a different type of faucets, the installation method of these faucets is very different from normal faucets, and not every faucet installer is able to install these faucets. These valves are usually installed in two stages.

The phase of installing the chassis and substructure of the valve is done before tiling, and the second phase and the installation of the main part of the valve is done after the completion of construction operations. These types of valves are very expensive both in terms of installation and the valve itself.

Installing a wash basin

Other accessories that are installed during the installation of faucets include the sink. Dish washers are usually installed in bathrooms, bathrooms, and next to Iranian and foreign toilets for hand and face washing.

In the past, the sinks were made of porcelain and ceramics, but with the luxury of the buildings, progress was made in the construction of sinks and all types of sinks with MDF cabinets, VC foundation, wood, glass, stone, etc. Luxury materials were introduced to the market. Released. In general, their installation is not much different from sinks.

When installing the sink, in addition to fixing the sink, we must pay attention to the level, distance to the door and walls, and the height of the sink installation. The installation height of the vanity is about 80 to 90 cm depending on the average height of the users.

Installation of sanitary ware

The installation height of the mirror is about 155 cm. Obviously, this height and distance can be a matter of taste and depending on

the height of the residents, it can be increased or decreased to some extent. But it should be installed according to the average height of the residents.

New washbasins are installed in types with and without a base. The use of appropriate and antibacterial screws, fittings and adhesives is very important in a good installation.

Toilet installer

In installing a toilet, it is very important to observe the axis and distances, seal the hood, adjust the float and outlet, and tighten the flange. At the end of the work, after installing the pavilions, they should be tested like the shiralats.

A strong body should use a large toilet, because using more than the designed weight may damage the toilet. Wall-mounted toilets and built-in flush tanks are considered luxury.

Heating installer

When installing the heating radiator, pay attention to the distance between the valve and the two pipes. In general, the distance from the axis to the axis of the radiator is 500 mm, which, of course, is less in some radiators.

After installing the radiator valve, the coupling, the cap of the radiator pipes must be closed. Covers and pipes are fittings that are covered on one side of the radiator and installed on the top and bottom valves of the radiator on the other side.

In addition to using quality faucets, it is very important to use washers and Teflon tape instead and in sufficient quantity to install the faucet. Of course, the quality of plumbing is very influential in the quality of faucet installation.

Repair of apartment faucets

Faucets in apartments and motorhomes do not function properly after some time due to the amount of deposits and sulfates inside the

faucets. If you arm these taps from time to time, fewer taps will have this problem.

In some buildings, if the number of these valves in the engine room is large, the plumber and facilities can remove the sediments to a large extent by acid washing and washing these valves.

Installation of electrical switches and sockets, door phone and coolers

Installing switches and sockets is one of the skills that anyone with little experience can do easily. If you have expertise in this field.

Important safety tips for installing electrical switches and sockets

Remember to turn off the power when installing the fuse.

When installing the outlet, make sure that it is firmly installed so that it will not be damaged during use. Nestek sockets have a child guard to prevent the dangers of inserting sharp objects into the socket. Remember never to touch the electrical outlet with wet hands.

Standard installation of switches and sockets at height

The installation height of switches and sockets is one of the most important things that must be considered correctly in the electrical wiring plan of the building. This standard varies depending on different places such as kitchen, bathroom or bedroom. Also, the standard of installing the switch box and socket together must be observed. Here are some tips on maintaining the distance when installing switches and sockets and related standards.

Note that when installing switches and sockets next to each other, the distance from the center to the center of the electrical boxes, considering the separator, should not be less than 91 mm. Of course, this distance should not be less than 71 mm regardless of the separator.

The standard height of the light switch from the ground is 110 to 120 cm.

The standard height of the bathroom exit from the ground is 120 cm.

The standard height of the outlet in the kitchen is 60 and 120 cm from the ground.

The standard height of electrical outlet, telephone and antenna is 30 to 40 cm from the ground.

How to install switches and sockets with a single-box

The tools needed to install the switch and socket in the single house box

Electric socket mechanism, key box, single socket, phase meter and two-way screwdriver.

Step 1: Identify the electrical wires

We determine the phase and neutral wires with the help of a phase meter. For this purpose, we carefully connect the phase meter to each of the wires and stick our finger to the bottom of the phase meter. If the light of the phase meter lights up, it means that the wire is of the phase type. Otherwise it is absurd.

Wire detection by phasemeter

Don't forget to turn off the power fuse after identifying the wires. And make sure it's off.

The second step: installing the electrical outlet mechanism

At this stage, to install the electrical mechanism, we open the top of the outlet with a screwdriver. Then we connect the phase and neutral wires to the terminals of the electrical mechanism. After that, we put the outlet in the electrical box. Finally, we close the tentacle screws to secure the mechanism in place.

Installation of electrical outlet mechanism

The third step: installing the crystal frame of the single house

Now we place the crystal frame on the socket mechanism and lock it in place. We put the upper part of the outlet on the frame and close the screw with a screwdriver.

Installing the frame on the mechanism

Step 4: Connect the power fuse

Finally, we connect the power fuse.

How to install switches and sockets in the framework of double-box

When you decide to install the socket individually, you follow the procedure mentioned and use a single box. In addition, you need two houses to install the switch and the mechanical socket together. How to install the output mechanism in the framework of two houses is done exactly according to the approach we explained above. Therefore, to avoid repetition, we skip this part and move on to the mechanical key installation method.

Electric socket mechanism, two-sided frame

Step 1: Identify the electrical wires

In this part, like the output, we must determine the type of wires with the help of a phase meter. Here, the black wire is the phase, the blue wire is neutral and the yellow wire is the return from the lamp or the same load.

Detection of electrical wires

Second step: installing the lighting switch mechanism

First, we need to open the top of the power switch. Then we connect the phase and neutral wires to the L and N terminals, respectively. We connect the return wires from the lamp or load to the corresponding terminals. After that, we put the mechanism inside the electrical box and tighten the screws of the fork so that it is fixed in place.

Installation of lighting switch mechanism

The third step: connecting the box

At this stage, we place the two house frames on the connected mechanisms inside the electrical box. We put the top of the key on the frame and close the top of the outlet with a screwdriver.

Step 4: Connect the power fuse

At the end, we connect the main power fuse.

Buying and installing a radiator

As we said in the buying guide for the best wall-mounted package available in the Iranian market, the packages are prepared and produced in a variety of wall and ground, gas, electric and oil-burning models.

Considering that most of the packages used in our country are gas-burning, in order to protect the health of consumers, rules have been adopted regarding the installation of the package, most of which are related to the installation location of the package.

Combi boiler installation location

You may imagine that you, as a combi boiler user, can install your combi boiler anywhere in the building, such as the balcony, kitchen, garage, under the stairs, balcony, and even the bathroom or basement of the building.

Places where installation of the combi boiler is prohibited

It is forbidden to install the combi boiler in buildings with an area of less than 60 square meters:

The reason for this rule is that if the combi boiler has an incomplete combustion, it can produce carbon monoxide gas. If the building has a small area, the exit ways of this dangerous gas from inside the building are very limited and in this way it can be dangerous for the residents.

On the other hand, another problem is that the gas package needs oxygen to cause combustion, and if there is a lack of space, the wall or ground package absorbs its oxygen from the surrounding environment, which again causes damage to the residents of the building. Through the reduction of useful oxygen in the place

Experts believe that in order to solve this problem, that is, to reduce the possible risks of installing the package in buildings with an area

of less than 60 square meters, pre-institutions have been presented as a solution to this problem, which we will mention below.

Using a double-walled chimney

Double-walled or double-layered chimneys have two layers, one layer of which is responsible for the release of smoke resulting from the combustion of the package, and the other layer directs fresh air or oxygen from outside the building to the package.

By using this chimney, the air required for the combustion of the package is supplied through the free air outside and is not consumed from the air inside the building.

Use a separate add-on such as an air vent for the combi boiler

This is another method of providing oxygen for combi boiler that are installed in confined environments. Of course, keep in mind that if an air valve is used to supply oxygen to the combi boiler, the person using the package must be given sufficient information in advance about the importance of this valve being constantly open to prevent leakage in the cold seasons of the year.

Installing the combi boiler on the balcony or terrace

This case can eliminate the risks of poisoning due to lack of oxygen if the existing rules are followed in installing the combi boiler on the terrace.

It is forbidden to install a combi boiler in places such as bathrooms and basements.

Since these environments are humid, wall or ground combi boiler should not be installed in these places.

It is forbidden to install the combi boiler in the vicinity of other heating devices such as gas stoves and water heaters, as well as in the vicinity of cooling devices such as air conditioners and air conditioner valves.

It is forbidden to install the combi boiler in front of the refrigerator and freezer and there must be at least 100 cm distance between these two devices.

It is forbidden to install the combi boiler outside the building such as balcony and terrace without using the cabin to avoid strong wind and air flow.

It is forbidden to install the combi boiler in places that have a complete border (such as places with double-glazed windows).

Specifications of the suitable place to install combi boiler

The package should be installed in closed places (not open environment like outside the building).

If the combi boiler is installed inside the cabin, the distance between the combi boiler and the cabin should be at least 10 cm on each side.

The installation of the wall package should be done at a height between 1 and 2 meters from the floor.

The installation location of the combi boiler should be such that a separate chimney can be considered for it.

The installation location of the combi boiler in the building should be such that water branches can be used to carry out the piping of the package.

The combi boiler must be installed near one of the gas outlets and the location of the combi boiler should have easy access to the building's electricity.

The installation location of the combi boiler should be such that, if needed, it is possible to carry out the necessary measures for service or repair of the package.

The installation location of the combi boiler in the building should be such that the heating piping to the package can be done easily.

As we said in the above section, one of the most important prohibitions in the place of installation of the combi boiler is placing this device in the balcony or terrace.

Considering the importance of this issue and the small size of most buildings, we will explain the reason for this ban and how to solve this problem in small buildings.

Installation of yard and parking doors

The courtyard door is an important part of the facade of the building. The door can open into the courtyard and directly into the building or apartment. The main entrance door of the building is for the common entrance of all the residents of the building, so it must have a high quality of construction and installation so that, in addition to providing security, it does not need service and can be used for a long time.

The yard door and the metal door should be stronger and more durable than the apartment door. The combination of hard and strong metal and hardened and unbreakable glass is a good idea for the production of the courtyard door and the entrance door of the building because while it is safe, its beauty is eye-catching and according to the facade of the building, you can choose a model that matches the facade of the building. to match

Installing the door frame

The order and construction of the door should be done according to the size of its installation location. Accurate measurement of the installation location and consideration of the distance to the wind is extremely important, especially in places that have pre-made coils. Make sure that when measuring, to measure the width and height of each door, two parts perpendicular to the coil, one at the top and one at the bottom, one on the left side and the other on the right side are measured. (It is emphasized not to forget to install the wind deflector.)

Before placing the door frame, make sure that the diameters inside the frame are equal. For this purpose, place the measuring head in one of the corners of the door frame and measure the length of the rectangle's diameter carefully. Then measure the other diameter of the rectangle carefully. The important thing here is that the two diameters measured must be exactly the same size.

When installing the frame, pay attention to its placement in the direction of opening and up and down of the frame. There have been many cases where the door frame was installed upside down and they had to tear down the wall and remove the frame and re-install it, so accuracy in installing the door frame is very important.

When installing the frame, its upper part should be checked with a level, and before fixing the frame, its two sides should be checked with a level and plumb.

How to install an anti-theft door

There is not much difference between installing a patio door and an anti-theft door. But due to the weight of the yard door and metal parking door and such doors, if the anti-theft door is completely installed at the installation site, the frame should be installed first and then the door hinge should be installed.

Another important thing in installing an anti-theft door, yard door and parking door is the complete and firm connection of the door frame, because if you choose the strongest door, but the frame is not installed correctly, the strength and security of the desired door will be greatly reduced. Finds. To install the door frame, if you are sure of the strength of the frame, you can weld the door frame to the frame or waiting box, and if the door frame has an installation hook, fix the installation hook to the wall by construction. Materials. On the other hand, if the door frame is made of curved and light sheets, be sure to fill the inside of the frame with concrete or cement mortar after installation, so that the weakness of the door can be removed.

Types of parking doors

Knowing the different types of garage doors helps us understand the potential. Until we are aware of the various options available to us, we cannot say that our choice will be accurate and complete. Therefore, we will have a look at the types of patio and parking doors. These doors can be divided into different sizes. Below we will consider the most important of these dimensions so that you can choose the best option according to your conditions.

What type of garage door is it?

Garage doors are made using different raw materials. Each of these materials has its own characteristics and this causes the difference between the characteristics of different types of doors. The following examples can be mentioned among the most important cases.

Metal parking door: this type of door can be considered the best choice in most cases. Because despite the different designs and variety it has, its beauty is optimal. Also, its strength is acceptable for providing security.

Aluminum garage door: This type of door has a very high price and in addition, it is much less strong than a metal door.

Fiberglass patio door: The high cost of this door has made it less popular. Also, this door is light and not suitable for windy places.

Wooden garage door: This type of door is not recommended due to its vulnerability, flammability and low durability.

Metal door model for yard and parking lot

Different models of these doors can be classified based on their dimensions and construction type. For example, these doors are divided into the following types based on the number of hinges:

Single in the yard

Double garage door

Three metal garage door

The following classification can also be added to the category of these doors:

Framed door: Having a frame makes the door very strong and strong.

Frameless door: Frameless doors can be designed in different heights. Creating attractive designs on the top of the door is one of the features of this type of metal yard door.

According to the type of design, the types of metal doors for parking and yard can be included in the following list:

Simple iron garage door

Modern metal garage door

Classic courtyard door

Wrought iron garage door

Types of metal doors in the yard and parking lot in terms of opening type

But one of the topics that can be discussed about the doors is the difference in dimensions and available space at the installation site. Limited spaces always limit the construction and installation of doors. It is very important to choose doors with a suitable opening and closing mechanism for these places.

Hinged door: This door is the simplest and most widely used type of door in the yard and parking lot. The hinged door, which is made in single-leaf and double-leaf models, also has the ability to be automatic.

Rail metal door: The rail door is suitable for selected limited spaces. Of course, to install this door, there must be enough space on one of the two sides of the door to open and close it.

Under-ceiling door: Sometimes, when there is no place around the door to install rails and move the door, you can use under-ceiling types instead of rail doors. These types of doors are placed under the roof after opening, and this helps a lot to save space. Metal doors are usually not built under the roof, and the reason for this is their heavy weight.

Folding door: sometimes the number of hinges is increased in some doors and the folding mechanism is used to open and close them. In this mechanism, the door hinges (which are smaller than conventional models) overlap when the door is opened.

Automatic metal parking door

Considering the importance of the automatic door, we will discuss it separately in this section. Door automation has become commonplace for several years. The reason for this is the many advantages of these types of doors.

These benefits include:

Using technology to increase comfort and well-being

Increase the level of security

Avoid injury

The price is right

Beauty and luxury

No need to get out of the car to open and close each time in different weather

Saving time

Types of automatic door jacks

To choose the best check for your metal garage door, it is better to pay attention to the following points.

Consider the weight of the door hinges.

The dimensions of the door hinge can be effective in choosing the jack.

Choose the jack according to the amount of traffic and the opening and closing of the door during the day and night.

Suitable jacks for hinged metal doors are divided into two main and important categories:

Electromechanical automatic door jack: suitable for low traffic, high security and very resistant, suitable for doors with medium dimensions and light weight.

Automatic electro-hydraulic door jack: suitable for high traffic, high level security, optimal operation in heavy and industrial doors with large dimensions.

Preparation of as-built map only by a competent executive engineer

In the architecture and construction industry, "As-Built" refers to a map that shows the dimensions and existing conditions of a building, space or area. As-Built drawings should show the building exactly as it is now, as opposed to a design drawing which shows the intended or preliminary design of the building. This is an important distinction, as a constructed building will almost never exactly match the original design plans.

There are many reasons why building plans are inaccurate. Often, complications arise during construction that force contractors to change from the original plans. Or, over time, the building may have undergone several renovations and/or tenant improvements that were never properly documented on building plans. In any case, the As-Built design is intended to document the current dimensions and layout of the building and show the existing conditions "as is". Today, several different terms and spellings are used to refer to As-Built plans. These include: existing condition maps, record maps, measured maps, asbuilt (maps, plans, etc.), as-built or Asbuild (maps, plans, etc.).

As-Built designs are foundational and based on your remodeling project.

As-Built plans are maps or models that accurately show the dimensions and existing conditions of a building. When it comes to rebuilding projects, these documents are an important first step in allowing you to get a good look at what you have to work with. There are different types of As-Built plans that you can work with depending on the scope of your renovation. It's important that your As-Built plans are accurate to avoid costly mistakes that can throw your project timeline into a loop. Obtaining these documents is the starting point because overtime, buildings undergo renovations,

modifications, and design changes that are not documented in the original plans.

The reason for preparing the As-Built map

As-Built maps are prepared for two reasons:

Error during execution

For example, in a project after taking the foundation maps, it was found that in one of the axes, the axis of the column has been moved by two centimeters from its original location. Therefore, Ezbilt foundation maps, which include the above changes, were used to prepare shop drawings.

Changes applied before and during execution on execution plans with the employer's approval

For example, in the implementation of the water transmission line in the city, before the implementation, we noticed the presence of other facilities at the level of the executive line (according to the plans) and therefore the height of the line should be changed. And this causes changes in the plans, and for this reason, the plan and also the construction are prepared to determine the actual height of the pipeline for maintenance and repairs.

Who prepares As-Built maps? And how is it presented?

After the construction plans are prepared by the executive engineer and communicated to the supervising engineer, the supervisor checks and controls the compliance of the construction plans with the current status of the project and informs the supervising engineer of the defects through a written letter (the owner's foundation). But in case of approval, there is no need for a written letter and only the plans are sealed and signed by the executive.

The system loads the technical certificate for checking the engineering system (if all technical certificate documents are completed).

Considering that the supervising engineer has done all the inspections according to the approved plans until the construction plans are prepared and has announced the discrepancies until then at the time of completion of the work and delivery of the plans, there

is no need to deliver the approved plans to Not a supervising engineer.

Who is the competent executive?

According to Article 10 of the Executive Regulations, Article 33 of the Engineering System Law, the construction contractor is a natural or legal person who has a work permit from the Ministry of Roads and Urban Development (Housing and Urban Development) in the field of building construction, and in the form of a similar contract with the building owner, takes over the subject of the contract.

Which buildings need an executor?

As it was said, according to Article 9 of the Executive Regulations of Article 33, all the executive operations of the building must be performed by a competent executive. From this legal article as well as the rulings issued regarding unqualified executors, it is understood that even the demolition and minor repairs in the building must be done by a competent executor and the owners must use the services of these people.

Obtaining approval and gas branches

Gas distribution is one of the most important distributions in residential units, whether under construction or renovation, which must be set up according to the rules and conditions of the relevant piping and after the approval of the gas company's expert.

Gas distribution for any applicant or subscriber can be requested by accepting the regulations and conditions of use of natural gas for the requested unit. You must provide these documents to receive gas distribution or any change.

Required Documents:

Viewing the original birth certificate, national card of the applicant and obtaining a photocopy of it

Approval of engineering system organization or other competent authorities

Confirmation of relevant organizations regarding type designation

If necessary, the gas company can visit the subject of the request. Determining the capacity of the station meter, the type of cost list, the current costs of gas branching are among the duties of the National Gas Company, and the applicant for gas branching must have complete information about the regulations and conditions of using natural gas. The list of natural gas sales costs, etc., after accepting them, sign the natural gas sales contract.

Installing a natural gas branch or changing its capacity that ends in the city and surrounding villages must have the necessary facilities to create a gas branch, after the final approval of the gas company, it is possible to install a gas branch from a technical, safe and economic point of view. It is acceptable to install branches in and around cities and villages only if there are no legal obstacles.

In a situation where the creation of a gas branch is technically, reliably and legally possible, the assignment of the branch by receiving the costs of establishing the branch includes the cost of a dedicated line corresponding to the meter capacity of the unimpeded station. These branching fees are collected from the owner or the applicant, which does not prove that the gas branching is exclusive to the person.

What are the conditions of gas branching for exploitation?

Gas distribution for each consumer residential unit is unique to the same unit whose information is included in the natural gas sales contract. It should be noted that it is not possible to transfer or expand the gas branch from one property to another.

The subscriber does not have the right to move the branch, regulator, connecting pipe and contour of the measuring station, and in case of a change in the condition of the building where the location of the said devices and equipment is inappropriate, he must inform the gas company. Make the necessary arrangements with the gas company to temporarily cut off the gas. Note that you should not carry out demolition or reconstruction operations before the gas is cut off. In case of non-observance of this point, the co-owner or the current owner of the property or residential unit is responsible for compensating for the damage and responding to all real and legal authorities.

Gas branching and its criteria

Each property or residential unit can have an independent gas subscription for itself. If the applicants refer to a unit or a combination of several residential units for independent gas sharing, it will be implemented if there are no legal obstacles. In residential and commercial complexes, if the entrance doors of the block of units are independently and immediately connected to the public road and are located in the vicinity of the gas supply network, it is permissible to allocate a separate branch for each block of units in compliance with the established criteria.

Safety principles and sharing rules

Assigning independent participation to industrial, residential, commercial and administrative units, industrial towns, settlements, residential complexes located in complexes whose entrance doors are not independently connected to public roads. The internal gas network of the town, which is requested by the applicants, must be carried out under the supervision of the gas company and based on the latest standards of this company, which can have an internal gas network by observing such things.

There is no obstacle in assigning independent gas subscription to any of the business and service units located inside passages, garages, etc., in compliance with the rules and conditions of the safety principles of the gas company. There is no obstacle to using several units independent of the pressure reduction station by installing separate measuring devices in each unit in compliance with common regulations and conditions and safety principles, provided that the amount of consumption of each unit is specified and the bill is determined.

Determining the amount of common gas consumption

The capacity of applicants for housing sharing is determined based on the number of residential units and the useful infrastructure of the building. The amount of heating consumption in non-residential units such as office buildings, commercial buildings, etc. is confirmed based on the useful infrastructure of the determining unit.

Gas distribution for industrial use, food preparation and cooking, bakeries, etc. . . There is another group that needs to install more meters in order to use gas appliances in addition to heating consumption. The highest hourly consumption limit of gas-burning systems is a criterion for determining the station's meter capacity and paying the cost of re-establishing gas branching.

Obtaining approval by the Technical Engineering Firefighting Office

To make it easier for you to understand the steps of obtaining the approval of the fire department, in this section, some sample diagrams related to the steps of obtaining the approval of the fire department have been prepared for you, professional friends, that you can download. For free, fill out the form below to download this useful and valuable chart in less than 5 seconds.

According to the type of project and its use, among the works that should probably be done during the process of obtaining this approval from the fire department, the following can be mentioned:

Designing and calculations of the fire alarm and extinguishing system and providing relevant maps and correcting the placement schematic

Designing systems such as positive pressure in staircases, ventilation of parking lots, pumping system and tanks, emergency power network, etc.

Designing and choosing the right type of manual fire extinguishers, warning signs and...

In some cities, the municipality or the engineering system organization may be in charge of this approval.

Correct and principled implementation and communication with related experts in the fire department and receiving advice from them, as well as monitoring the implementation and testing of fire alarm and extinguishing systems and delivery from contractors, as well as monitoring the purchase of equipment such as smoke doors, pool peripheral equipment and other items other Required according to the standards and regulations of the fire department can greatly

reduce the difficulties and challenges of the fire department approval process for commercial and industrial buildings and centers.

End of operation

The completion certificate or the so-called construction completion certificate is one of the most important and final construction documents. In the previous articles, you learned about obtaining a building permit, now it's time to receive your completion certificate from the municipality after the complete renovation and construction of the building and breathe a sigh of relief.

Obtaining a certificate of completion is sometimes one of the biggest concerns of employers. By accepting all these cases (from zero to one hundred building renovations), Jufundasjonen Technical and Engineering Company solves the related mental concern. To get a termination of employment, you must go to the municipality of the region and go through the legal procedures by filling out the termination of employment request form.

In fact, obtaining a certificate of completion is one of the most important documents issued after the completion of construction. This certificate shows the strict implementation of construction safety rules and regulations and that the building is approved by the municipality and related organizations and specifies the ownership and use of the property.

The actions related to obtaining the completion certificate are usually the responsibility of the manufacturer. The completion of each building requires the submission of documents and confirmations of building strength by experts and supervising engineers through direct construction supervision or tests and visual expertise from the building site. Possession of the property does not prevent the termination of exploitation; But it may prevent the issuance of the property document.

What is the reason for the completion certificate?

The building completion certificate is one of the most important documents that is required in the Real Estate Registry Office to

prepare the separation plan. It is not possible to prepare the document until the completion certificate is issued. Even if the building has a title deed. The completion of building work is actually a condition for the existence of a document and the existence of a document is a necessary condition for real estate transactions. The certificate of completion is the most obvious feature of a property that is free of any construction violations and is built based on the engineering and technical standards approved by the municipality and the engineering system. When you receive the completion of the operation, it shows that your property has all the necessary conditions for operation.

If the building has obtained all necessary approvals and standards based on the legal provisions of the building permit. The supervising engineer can approve the completed form. In fact, the supervising engineer allows the building to be put into operation. The owner does not have the right to use the property before obtaining the end of operation from the municipality.

According to the national building regulations and the general guidelines for building and safety implementation, and considering that the issuance of the completion of the work depends on the complete start-up of the building. The complete start-up of the building includes all electrical installations, especially the earth and life protection key, etc., which is one of the requirements of the safety regulations of topic 13 of the national building regulations.

Mechanical facilities include heating and cooling facilities, which must be chimneys, ventilators, etc., among the requirements and items that must be visited and approved according to topic 14 of the National Building Regulations. The elevator must have an inspection certificate from the standard department or inspection companies. Also, the correct implementation of the railings and railings of the stairs and balconies must be approved by the supervising engineer so that the certification procedures can be carried out.

Conclusion of the contract of attorney for the implementation of document registration and separation of documents of the units

In order to buy and sell the property easily, the property must have a separate document or separation document, therefore, it is necessary to obtain this type of document (construction separation document) to separate and determine the assignment of each unit, after obtaining the completion of the construction work.

The same minutes of the meeting only deal with "defining the estimated size of the independent units and telling their square area and numbering them completely without addressing the private ownership of all the units."

The meaning of separation

Separation literally means to separate. In terms of registration, it is the division of a plot of land into different parts. Separation is a completely administrative process that is carried out at the request of the owner (owners) by the property registry office of the place where the property is located for joint and non-joint properties, and as a result, the property is divided into several parts with certain specifications.

Most of the time, the act of separation of real estates starts with obtaining a certificate of completion from the municipality by the owners and attaching the certified copy to the request of notary offices for separation and delivery to the real estate registry offices where the property is located.

The building separation document means separating the documents of the units built by the owner or builder (each unit has a separate document), but what is its use?

In order to buy and sell the property easily, the property must have a separate document or separation document, therefore, it is necessary to obtain this type of document (construction separation document) to separate and determine the assignment of each unit, after obtaining the completion of the construction work.

The same minutes of the meeting only deal with "defining the estimated size of the independent units and telling their square area and numbering them completely without addressing the private ownership of all the units."

The steps for obtaining a construction separation document are as follows:

- 1- Refer to the engineering system organization to obtain maps issued by that organization
- 2- Submitting the maps received from the Engineering System Organization to the Real Estate Registry Office
- 3- After completing the legal procedure, the time limit for obtaining building separation documents is 30 days.

What are the conditions for setting the minutes of the apartment separation document?

After building the apartment and obtaining the certificate of completion from the municipality, the owner must submit his request to the registry office through the notary office, then the registry office will order an inquiry to obtain a certificate of non-arrest, and in case of non-arrest, to inspect the place and finally The minutes of the separate meeting will be prepared.

What is the parking separation document?

In this case, in the construction of apartments, the parking and storage of each unit must be specified so that this issue is stated in the separation meeting and the property ownership document.

Light structures

LSF structure stands for Light Weight Steel Frame or light prefabricated structure. One of the main advantages of light steel framing is its versatility and a wide range of building types. Wall systems, and off-site modular construction are completely finished.

This system is one of the modern methods of implementing the structure, its use started in 1950 in some countries including Canada, but its widespread use was noticed in 1990. The factories

of this system were launched in Iran for the first time in 1385. (It has technical approval from the research center and has been officially introduced as a new technology) The main factor in this system is thin-walled steel sections. These sections are cold rolled metal sections that are formed using thin galvanized steel sheets.



Application

Villas, residential, office, industrial buildings up to three floors, hotels, hotel apartments, school and university buildings, restaurants, etc.)

Advantages of sections

Most materials are used in this system and all waste materials can be recycled.

They are resistant to corrosion, bending and cracking.

Can be ordered with exact lengths required.

The materials needed to make this system are at least 60% lighter than conventional materials.

The orientation of this structure is towards the technique of prefabricated panels, where the walls of the building are assembled in the factory under controlled conditions and then transported to the site for installation.

During the shaping and construction, a series of standard holes are made in the life of these sections, which makes it easier to pass the

wires and pipes through these holes to install utility systems inside the wall.

The weight of this structural system is about 30% compared to the traditional system.

Due to the light weight of this system, the required foundation is only under the load-bearing walls with the minimum dimensions used in the foundations, and under the internal walls, a concrete slab with a thickness of about 10 cm is used.



Reduction of steel consumption

Due to the use of sections made with thin sheets as well as the reduction of dead loads of the building, the weight of the skeleton of the structure is reduced by about 30-40%.

- The possibility of adding floors to the existing building due to the relatively lower weight of this system, by taking into account the possibility of increasing the floors of the building.
- Ease of assembly and separation of components, the connections of the members in this system in the workshop are in the form of screws and rivets, and it is possible to easily assemble and separate them.

High execution speed

Due to the manufacturing and preparation of panels in the factory, the installation operation in the workshop has an acceptable speed. (a turnkey villa for 2 to 3 months)

Environmental friendly

In wooden structures, it is necessary to cut a large number of trees to build a building, also some building materials cannot be recycled, but in this steel frame system, it is completely recyclable, and recycled steel can also be used to produce the structure. (About 435 million tons of steel are recycled in the world annually, which is equivalent to 150 Eiffel Towers per day.)

Flexibility in design

The architectural plan for this system has no limitations and there is the ability to design a structure for a specific architecture with different openings.

Building floor system in LSF

Very high weight and as a result the need for a stronger foundation and structure as well as absorbing more earthquake force, slowness of construction operations, high waste and waste of materials, causing a lot of pollution and dust during construction and demolition, lack of quality control of connecting materials (mortar)

) at the time of construction, weak connections and the possibility of falling during an earthquake and increasing human and financial losses

Lightness, speed in installation, a clean and dust-free process, cost-effective and economical (due to lightness, durability and easy transportation and quick installation), flexible design, safe against earthquakes (due to light weight and system appropriate retainers)

Different alternatives for system components of walls, floors, ceilings, doors and windows

Covering the internal walls: after placing sound and thermal insulation between the wall studs, 15 mm thick plaster panels are used to cover them on each side. (The surface of the panels can be painted, wall papered, wooden and plastic covers after adjusting and puttying)

- Covering the external walls: first, a layer of plywood with a thickness of 15 mm is used, and all facades can be applied on it (types of plasters, aluminum facade, cement panel, etc.).

Floor covering

- The floor of the ground floor: using a concrete slab with a thickness of 10 cm and implementing ceramics, flooring, etc.

Floors: After installing floor joists, the following systems can be used. Installation of 15 mm thick plywood and (thermal and sound insulation between them) and applying sand, cement and ceramic mortar or flooring and...

- Implementation of flooring and ceramics using glue (removing sand and cement mortar)
- Using sinusoidal sheets with a thickness of 0.8 mm instead of plywood (and installing heat and sound insulation between them) and meshing with 8 reinforcement and pouring concrete with a thickness of 8 cm and implementing ceramics or flooring.

Roof covers

The roof of these types of buildings is implemented in two types, flat or sloping.

Flat roofs

- 1- Applying plywood on the roof joists, slope mortar and isogam layer
- 2- In case of low traffic on the roof (according to the building use), remove the slope mortar and perform isogam on the plywood
- 3- Use sinusoidal sheets On the joists, mesh, 8 cm thick concrete layer, slope mortar and isogam

Sloped roofs

- 1-Installing plywood on the structure and implementing a clay roof
- 2-Using sandwich panels on light structures
- 3-Using metal sheets or colored pottery on the structure (such as shades)

Doors and windows

In this system, there are no restrictions on the type of doors and windows and you can use PVC, upvcc, wooden, aluminum with double or single glass.

Details of LSF structure

Iran is one of the countries that has struggled with earthquakes and various natural disasters in recent years. The occurrence of such problems has made construction with new and new methods become very important. One of the new construction methods is the LSF method, which we want to examine today. The main purpose of LSF is to reduce the weight of the building. This type of structure, which is a prefabricated system, is used in many constructions today. The LSF structure consists of open thin-walled steel sections that are cold-rolled on a thin metal sheet. The many advantages of this system, such as being prefabricated, high execution speed, good compatibility with the environment, good seismic resistance, and economical use of this system have been greatly welcomed. Since in Iran, most of the production sheets with thicknesses of 2 to 6 mm have limited use and also due to the existence of cold rolling technology in the country; There is a possibility of industrial production of building in the country based on the development of the use of light cold rolled sections, and if this technology is used, there will be a clear perspective in the building industry.

History and reasons for using the LSF structure in different countries

The LSF structure, which has been widely used in developed countries in the past years, has been used as a suitable solution to solve the housing shortage problem. It has attracted the attention of officials and decision makers in the field of construction and housing in our country. This prefabricated system, which is known in most countries of the world due to the studies and research done in the country and has created significant benefits in construction, is considered a very new and unknown system in our country. In the following, we will fully examine this structure. Since the prefabricated systems are of high quality, it helps to increase the

useful life of the building and the durability of its construction and improves the resistance of the structure against earthquakes. Their

use has become very common in recent years. From another angle, the interest in building structures quickly to solve the problem of housing shortage has made the use of these methods customary. The use of industrial methods (such as LSF) has replaced old and traditional materials. The meaning of this talk is that with the change of construction methods, the materials that were used to build old structures lost their efficiency and as a result new materials replaced them. The materials used in the new construction are of very high quality compared to the old ones.

How to implement LSF structure

To implement the LSF construction system, like other common construction systems, architectural and structural plans are prepared first, and then executive plans are prepared and the system is implemented based on that.

During the implementation of the foundation, strips with a depth of 40 to 50 cm are used to install the wall. In the next step, the reinforcement, molding and concreting of the anchor bolts are done with a standard distance in the foundation and the walls are installed. The standard distance defined for the foundation is usually between 40 and 60 cm. After the foundation, it is time to build the walls. To implement the wall using the anchor bolts used for this purpose, the floor tracks are first installed and then the masters are placed inside the floor track in a sliding manner. Tracks are horizontal members that cover the professors from above and below in a sliding manner. Master is one of the main parts of wall construction and installation, which is responsible for bearing the load of the floor. In the LSF building system, the master and routes are part of the main members. These members transfer the load to the support as a panel. The bearing wall is responsible for transferring the vertical load of the building, absorbing the lateral load and protecting against wind and earthquake.

Non load bearing walls are mostly used to separate the interior space of the structure. In order to facilitate the passage of the installation, the masters are drilled before installation. These

professors are connected to the tracts with a distance of 40-60 cm. In the LSF construction system, walls are usually constructed by

connecting steel piles to steel tracks. By installing gypsum panels, they are coiled and made into panels. In case of adding wind braces of this construction method to resist lateral loads; It is very suitable for wind and earthquake loads. Belts are made using thin sheets with a thickness of 0.8 to 2 mm.

roof

Different implementation methods are used for the roof in the LSF system, so that all types of roofs can be implemented from simple flat forms to cross roofs with uneven slopes. There are two types of the most common roof implementation methods. Roof trusses that usually span a building from front to back. A flat joist system that is usually used between supports or shared load-bearing walls to implement flat roofs.

In the construction of intermediate ceilings in the LSF system, the beams are generally done along the walls. Each of the beams usually transfers its load directly to the master workers. The above parts are usually made and implemented with C or Z shapes. Covering these types of roofs is usually done with concrete or by installing wooden or plaster boards. In areas with strong winds or earthquakes, the roof frame should be braced. In addition, in order to resist the wind and raise the roof, a suitable connection between the load-bearing walls and the roof should be selected. Implementation of foam and Rofix in addition to creating sound and thermal insulation. It prevents the penetration of concrete juice during concreting.

facilities

As mentioned, CFS sections that are used as roof beams or master walls have holes along the length of the member that are used for passage and installation of utilities. Due to the prefabricated system and the use of screw connections, access to the connections to repair, repair or replace some parts is easily possible, and as another advantage of the LSF system, it also increases the useful life of the building. Is considered.

Comparison of LSF system with metal and concrete frame systems

In order to clarify the differences between the LSF structure and the traditional systems common in the country in the construction of short and medium-sized buildings, several different projects using common steel structure systems are presented in this section. The concrete structure and LSF system have been designed and the obtained results have been compared. The completed projects include 3 two-story, three-story, and five-story buildings that were designed using all three methods and a fairly comprehensive comparison of the results was presented.

The use of LSF structures in the construction of 1- and 2-story residential buildings, villas, offices, small business offices, educational and industrial units due to many advantages such as lightness, economy, low consumption of construction materials, increasing useful internal space, good sound performance And low energy consumption is common in many countries of the world. It should be noted that about 300 kg of raw materials are needed for each square meter of LSF structure, and the remaining waste will be less than 2 to 3 kg. Meanwhile, in traditional systems, the raw materials collected from nature are more than 1000 kg, which will bring at least 100 kg of non-recyclable construction waste. In this way, if, for example, 100,000 residential units of 75 meters (equivalent to seven and a half million square meters of buildings) are implemented with the LSF system, significant savings in the use of national resources will follow

Chapter two

Steel structure

It is a group of steels that are used to make construction materials in various forms. Many forms of steel framing are in the form of a long beam with a defined cross-section. Structural steel shapes, sizes, chemical composition, mechanical properties such as strength, storage methods, etc., are regulated by standards in most industrialized countries.



Metal forms of various structures

Most structural steel shapes, such as I-beams, have high second moments, meaning they are very stiff in cross-section and can therefore carry high loads without much sagging.



Steel frame roof at Manchester Victoria Station

Common structural forms

Shapes are described in many standards published around the world, and there are a number of specialized sections.



A metal I-beam used in this case to support wooden beams in the house.

I-shaped I-section beam - in the UK it includes universal beams (UB) and universal columns (UC); In Europe, it includes IPE, HE, HL, HD and other departments; In the US it includes a wide flange. (WF or W-Shape) and section H)

Z shape (half of the flange in the opposite direction)

HSS-Shape hollow structural cross-section, which is also known as SHS (hollow structural section) and includes

square, rectangular, circular (tubular) and elliptical cross-sections.

Angle (L-shaped section)

Structural channel, or C beam, or C section

Tee (T-shaped section)

Rail profile (asymmetrical I-beam)

- Railway tracks
- Vignole rail
- Flanged T rail
- Grooved rail

Rod, a long piece with a rectangular cross-section, but not so wide as to be called a sheet.

The rod has a round or square section compared to its length.

See also rebar and dowel.

Plate, metal sheets with a thickness greater than 6 mm

Open web metal beam

While many sections are made by cold or hot rolling, others are made by welding flat or curved plates together (for example, the largest circular hollow sections of flat plate bent into a circle and seam welded).

Standard metal structure

Steels used for building construction in the United States use standard alloys identified and specified by ASTM International. These steels have an alloy identifier that begins with an A followed by two, three, or four numbers. The four AISI metal grades commonly used for mechanical engineering, machinery and vehicles are a completely different set of specifications.

The standard structural steels that are commonly used are:

Carbon steels

A36 - structural and pipe shapes

A53 - structural pipes and tubes

A500 - structural pipe and tube

A501 - structural pipe and tube

A529 - structural forms and plates

A1085 - structural pipe and tube

Low alloy steels with high strength

- A441 - structural shapes and plates (replaces A572)
- A572 - structural shapes and plates
- A618 - structural pipe and tube
- A992 - Possible applications are W or S I-Beams
- A913 - QST mute and self-quiet W forms
- A270 - structural shapes and plates

Low alloy steels with high strength and corrosion resistance

- A243 - structural shapes and plates
- A588 - structural shapes and plates

Quenched and tempered alloy steels

- A514 - structural shapes and plates
- A517 - Steam boilers and pressure vessels
- Eglin Steel - cheap aerospace items and weapons

Forged steel

- A668 - metal forging



Screw set without preload (EN 15048)



Preload screw set (EN 14399)

CE marking

The concept of CE marking for all construction products and metal products is introduced by the Construction Products Directive (FPC). CPD is a European directive that ensures the free movement of all construction products within the European Union.

As metal components are "safety critical", CE marking is not permitted unless the Factory Production Control (FPC) system under which they are manufactured has been assessed by an appropriate certification body accredited to the European Commission.

In the case of metal products such as sections, bolts and fabricated steels, the CE mark indicates that the product complies with the relevant harmonized standard.

For metal structures, the main harmonized standards are:

- Metal sections and plates – EN 10025-1
- Hollow sections – EN 10219-1 and EN 10210-1
- Loadable bolts and nuts - EN 14399-1
- Non-load bearing bolts - EN 15048-1
- Fabricated steel – EN 1090 -1

The standard that covers CE marking of structural steel is EN 1090-1. This standard came into force at the end of 2010. After a two-year transition period, CE marking will become mandatory in most

European countries in early 2012. The official end date of the transition period is July 1, 2014.

Steel frame

Metal framing is a construction technique with a "skeletal frame" of vertical metal columns and horizontal I-beams built in a rectangular grid to support the floor, ceiling, and walls of a building, all connected to the frame. The development of this technique made the construction of skyscrapers possible.



Metal frame development



The rectangular metal frame, or "perimeter frame" of the Willis Building (right) is contrasted with the Diagrid frame at 30 St Mary's Ox (centre), in London

History

The use of steel instead of iron for structural purposes was slow at first. The first iron-framed building, the Dithrington Flax Mill, was built in 1797, but it wasn't until the Bessemer process was developed in 1855 that steel production became efficient enough for steel to become a widely used material. Inexpensive steels with high tensile and compressive strength and good ductility were available from about 1870, but wrought iron and cast iron continued to meet most of the demand for iron-based construction products, largely because of the difficulties of producing steel from alkali rocks. . These problems, caused mainly by the presence of phosphorus, were solved by Sidney Gilchrist Thomas in 1879.

It wasn't until 1880 that the age of reliable mild steel construction began. At that date, the quality of steel produced was reasonably well established.

The Home Insurance Building, completed in 1885, was the first building to use skeletal frame construction, removing the load-bearing function of its masonry entirely. In this case, the iron columns are simply embedded in the walls and their load-bearing capacity appears to be secondary to that of the masonry, especially for wind loads. In the United States, the first metal-framed building was the Rand McNally Building in Chicago, built in 1890.

The Royal Insurance Building in Liverpool, designed by James Francis Doyle in 1895 (built 1896-1903), was the first building in Britain to use a metal frame.

Types of metal building frames



Clearspan frame Clear span frames do not require internal support beams, which allows unobstructed use of the entire interior space of the building. Clear opening frames can be symmetrical gable (two slopes with a ridge in the center of the building and both roofs of the same height), asymmetrical gable (two slopes with an off-center ridge and both edges are the same or different heights) or Single pitch (single pitch with no overhang and both roofs of different heights), symmetrical gables are the most common and with a higher pitched roof, can provide a significant amount of overhead space for a car lift or framing of additional space for warehouse use. Provide. A single slope is common in areas with heavy rain or snow, as it allows the roof to shed excess rain or snow to one side. Additionally, a slope is ideal for retail buildings where a mansard or parapet is desired for a more elegant entrance.



Leanto frame

The Leanto frame is attached to and partially supported by the main frame of the building. They are usually a single slope design and have straight side columns. While a lintel frame can follow the

slope of an existing building roof, most lintels are below the edge. A buttress below the edge on each side of a fully enclosed building and running the full length of the building creates what is commonly known as a monitor or elevated central warehouse. Leanto style buildings are expensive because both the structural engineering they are attached to and the foundation engineering complicate the project. Additionally, in snowy areas, battens create the potential for snowdrift loads at the point where the batten attaches to the main building below the threshold. For customers simply looking for roof-only shelter for equipment, a built-in building is a more cost-effective alternative.



Modular frame

Modular frames use internal bearing columns to evenly distribute the load of the entire building. A modular frame works very well for projects that require very large metal buildings. Adding an interior or intermediate column in wider buildings, especially those with high snow loads, helps reduce beam and column size and makes the project more economical.



Gambrel frame

In addition to being a traditional architectural style, the Gambrel frame has aesthetic and practical benefits. Ceilings that originate from the wall plate of the first floor, in the way that gables and cloaks do, not from the second floor. Such ceilings are more interesting and visually pleasing. But the gambrel has advantages over the shell: in particular, the gambrel gives more useful space in the frame volume.

Application and features

The need to use a metal frame is due to its considerable strength and durability. In today's world, we see metal skeleton everywhere; From the construction of all kinds of bridges to buildings, silos, petrochemical industries, etc., but do you know what types of metal skeletons are? What are the characteristics of each and in which parts of the building are they used? To know how many types of metal skeletons there are and what are the characteristics of metal skeletons, stay with us.

An important point is that rebar is an important and common member among all structures; For this reason, the price of rebar can be one of the factors that affect the overall costs of your project.

Components of the metal frame

According to its nature, steel structure is made by connecting several components to each other.

Steels are produced and used by changing the microstructure by performing the necessary heat treatment. Steel is an alloy composed of two types of materials, carbon and iron, and by adding additives

to it, such as sulfur, chromium, nickel, phosphorus, and manganese, it acquires special properties. For example: adding copper improves the corrosion resistance properties of steel.

Higher yield strength and tensile strength can be achieved by adding manganese and carbon, although there are two downsides, making the end result harder and the steel less ductile.

Corrosion resistance and high temperature resistance are other features of the metal skeleton that can be strengthened by adding nickel and chromium. The fatigue strength and welding ability of this product can be improved by adding sulfur and phosphorus to it. Today, metal structures are used in various fields, such as building skeletons, especially tall buildings, construction of bridges, fluid storage tanks, etc.

Different types and grades of steel

Different metal sections that are considered for the metal frame include rebar, beam, profile can, metal pipe, etc.

Carbon steels

Carbon steel is one of the commonly used steels in many industries, which, while being affordable, also has excellent mechanical properties. Carbon steel usually consists of 0.05 to about 2.0% by weight of carbon, plus iron and small amounts of other elements.

This steel is mostly used to make pipes that are used in metal framework.

Low alloy steels with high strength

HSLA steel stands for "High Strength Low Alloy" meaning high strength alloy steel. This type of steel is also known as "microalloy steel", which has better mechanical properties and high corrosion resistance.

Adding alloy elements to this steel increases its strength and hardness. Alloy elements such as tungsten, vanadium, silicon, nickel,

molybdenum and manganese are among these alloys that are added to microalloy steel to increase strength and hardness.

Metal frame components

A metal frame generally consists of four components:

1. Beams
2. Column
3. Tensile components
4. moment and compression components

Beams

Beams are an important and inseparable member of a metal structure; It means that a structure cannot be completed without them. The plate column, bottom of the stairs and load-bearing sheets are also a small member of the beam.

columns

The presence of columns is necessary for a metal structure, and beams or cans and profiles are used to make columns. If they use a profile can; They should pour concrete inside the columns to give more strength to the structure.

Tensile components

Tensile components of a structure are designed to maintain and transfer tensile axial loads.

Moment and compression members

Bending members are hard connections in the structure that are executed in a cross shape and must connect the bending frame system together. Beams are the most important part of the bending frame system. These bending members must be so strong and durable that the structure can withstand high pressures.

Advantages and disadvantages of various types of metal structures

Metal frame structures, like any other type of building, have their own problems and advantages. Metal skeleton has many advantages, the most important of which are mentioned below.

Advantages of using a metal frame

It is possible to strengthen the metal frame at any time.

The overall speed of construction when using a metal frame is remarkably high, which can help reduce construction costs.

Steel has high strength against tension and pressure applied to the building, and its use increases the resistance of the building.

Weldability, easy formability, as well as spring and elastic properties are other features of using metal skeleton.

The metal frame has a high toughness value. Therefore, they are very suitable for construction applications. (The ability of a material to absorb energy is called toughness.)

Metal frameworks make different architectural designs possible. Amazing and beautiful metal buildings, towers and bridges can be seen all over the world.

Disadvantages of metal frame

Of course, along with all these features and advantages of metal frame, these types of structures also have disadvantages:

Corrosion is an important issue in metal framing: In general, any building constructed with metal framing, especially if exposed to wet weather (such as bridges), is more susceptible to corrosion. Hence, it needs regular maintenance and this is one of the most common problems with metal frame.

Steel frames are often more expensive than other types of structures: this makes them less attractive for smaller projects with limited budgets.

Steels are generally not strong against fire and heat and change their shape and even fall to some extent.

Types of steel structure

When it comes to the type of structure, choosing the most reliable type of structure is an important issue that you should pay attention to. Metal frame is better than other types of structures such as concrete. Of course, the important thing is that you can know the types of this structure and use each of them according to their characteristics and applications for different purposes.

In general, types of metal skeletons can be divided into 4 categories:

1. Suspension structure
2. Framed structure
3. Truss structure
4. Shell structure

Suspended structure

This type of structure will be used in suspension bridges or long roofs where a lot of tensile force is applied to the structure members. The framed skeleton in this type of structure is suspended by stretched cables.

Frame structure

The frame structure consists of vertical metal columns and I-shaped horizontal beams, which basically form a metal skeleton frame. If the structure is supposed to be very high, it is necessary to use a frame structure; Because it supports the ceiling, wall and floors well.

Beams play an important and effective role in the frame structure, and for this reason, the price of the beam can influence the price trend of this type of structure. Among the most important applications of metal frame structures, the following can be mentioned:

- Use in high-rise buildings such as multi-story buildings and skyscrapers
- Can be used in warehouses

Can be used in industrial buildings

Can be used in residential buildings

Can be used in temporary structures

Note: The frame structure needs strengthening, because it becomes soft and destroyed due to heat.

Truss structure

The metal frame of the truss, with its triangular appearance, can well bear the tensile and compressive force and transfer it to the structure. This type of structure can be produced in three types: simple, compound and complex. The truss structure can be reused in some applications.

shell structure

Shell metal skeleton is one of the types of metal structures that is made with a special geometric shape and relatively less thickness. This product is made of cylindrical and spherical thin sheets; Therefore, its use causes the weight of the structure to decrease significantly.

A shell structure with a spatial volume like a cylinder is used to build silos and fluid storage tanks in factories, etc.

Steel structure foundation

The most common construction methods around the world are three construction methods with steel frame, building materials and concrete frame. The metal frame consists of metal beams and columns. Building a metal frame building is similar to building most other buildings, starting with a strong metal frame foundation.

Before the steel frame foundation is built. The land should be professionally surveyed to ensure that the construction surface is level and that the builders know the exact boundary of the plot. Then the classification or physical leveling of the building begins. Grading includes determining the height and shape of the land according to the surveyor's scale.

When the construction surface is built. Excavation for the foundation can begin. You should consult with the metal building

manufacturer or vendors regarding the method of excavation of the steel frame foundation you need. Most simple metal buildings require only minor excavation, while more complex metal buildings require deeper excavation. Minor excavations can be done with hand tools such as shovels and rakes. Excavation mainly involves the use of construction equipment such as excavators. Steel frame construction is usually used in high-rise, warehouse, industrial, residential, etc. buildings.

The duty of the metal frame foundation

The foundation of the structure must transfer the weight of the building to the ground in such a way that:

Avoid settlement too much and inappropriately in the building.

In case of settlement, this amount should be exactly the same and each part should not be involved in different shapes and sizes.

The load entered from the side of the building to the bottom of the structure should not cause damage to the lower part of the building. The foundation of the building must prevent the total overturning of the structure when the lateral force is applied to the structure. The metal frame foundation is the most important part of the metal building and it is the part that causes the most damage to the building over time. Uneven walls, basement leaks, or structural deformation and damage may result from a weak foundation.

Types of metal frame foundations

The building foundation has different types based on the type of building, structure and construction system, each of which is used depending on the type of building and structure. Metal framework is divided based on the type of materials, including concrete, shaft, stone and brick foundations.

The foundation is located at the lowest part of the building and considering that the load of the building is transferred to the ground through it, the strength of the metal frame foundation plays a very important role in the stability and strength of the whole building.

For the construction of all buildings with any type of use, it is necessary to comply with the foundation regulations and national

regulations in the construction and implementation of the foundation. Depending on what type of foundation you will use for your structure. The necessary functions are checked and performed. These functions and rules are implemented to ensure the necessary balance between building loads on the ground. Because of this issue, you must know the effective lashes of all foundations. To implement each part of the structure (both in the foundation and in other parts), you must choose the right materials. For example, you should know the types of rebar and make the right choice after checking the construction site.

Metal frame according to the type of material

Stone foundation

This foundation is made of natural stones and in areas where cheap stone is available, stone is chosen for such foundations. The stones must be healthy (not rotten) and of the type of broken carcass stones. Polished and rounded stones are not suitable for foundation because they give an unstable state to the metal frame foundation. The surface of the stone foundation should be wider and wider than the walls on which it is located, and there should be at least 15 cm from each side of the wall as a root. Stone foundation is made with two types of mortar. If the load is high, sand and cement mortar is selected, and if the load and pressure is low, mud and lime mortar is selected.

Brick foundation

Brick foundation is used when the building is small and the load is low. This metal frame foundation should have a root between 15 and 20 cm from the sides of the wall on it, just like the Haisengi foundation. For this purpose, the width of the foundation is cut 30 to 40 cm more than the width of the wall. This extra width also makes it easier to work the porcelain brick inside the foundation.

The load distribution angle in the excellent brick foundation is about 60 degrees. In order to save brick consumption, we suggest making it in steps.

Lime concrete Foundation

The simplest and most basic construction of the foundation for small brick structures of 2 or 3 floors. lime concrete foundation is made from a mixture of soil, water, sand and a little lime. Sometimes they add a few pieces of stone as needed. The method of making the shaft is that they pour the shaft into the foundation and after the shaft reaches about 20 to 30 cm, they smooth it on the horizontal surface and let it rest for a day so that the moisture evaporates. or reduced absorption is then pounded with a heavy weight until fully compacted. Shoveling is done again at the same height and continues until the entire metal frame foundation is filled.

Concrete foundation

Concrete can be called one of the strongest and most resistant artificial stones. Because metal frame foundation structures made with concrete are considered the best foundation in construction works. Today, it is recommended to build the metal frame foundation of all buildings with reinforced concrete, especially in earthquake-prone areas.

The load distribution angle in concrete foundations is between 30 and 45 degrees. Such foundations can be made in a stepped or incomplete pyramid (Somel) form and avoid excessive consumption of concrete. Foundation construction with concrete is done in such a way that the bottom of the foundation is filled with about 10 cm of low-cement concrete called makar. To separate the surface of the soil and the main concrete and level the surface of the foundation for the main concreting. Then the concrete is molded with a board and after the mold is ready, the concrete is poured into the mold and beaten well with the help of a vibrator so that the concrete settles, that is, the sand grains are condensed in the concrete. The next operation on the concrete foundation should be done at least seven days after the foundation. It should be noted that if the concrete is of reinforced type, first the rebar is embedded in the mold, then concreting is done.

Steel frame according to the production system

Point foundation

For buildings whose pressure and load are transferred to the ground in a concentrated (point) manner, this metal frame foundation is made.

Dot foundation layers

Flat and suitable land

pure concert

Foundation floor bars

Original concrete

The plate under the column in the metal frame foundation

Strip foundation

This metal frame foundation is used to bear the load of a load-bearing wall and the load of a row of columns that are aligned with small distances. The ratio of length to width in this foundation is generally more than 10. In some references, this ratio is considered greater than or equal to 5. The width of this foundation has an inverse relationship with the bearing capacity of the soil and has a direct relationship with it. The lower the load of the structure and the higher the bearing capacity of the soil, the smaller the width of this foundation will be.

Extensive foundation

Wide foundation is also called radial foundation, integrated or general foundation. The general foundation throughout the lower part of the building is made of reinforced concrete and all the columns and walls are placed on it. This type of foundation is used in cases where the loads from the building are very high (such as towers) or the compressive strength of the ground is so low that the entire lower surface of the metal frame foundation is needed to transfer the load. The soil under the pressure foundation should be

done on a larger surface. The permissible settlement of the wide foundation is 8-30 cm.

Flat foundation

The entire lower surface of the building is used to transfer the load to the soil. The foundation of a reinforced concrete plate is made from the top to the bottom of the building, on which the bars of the columns and the wall are placed. In some cases, the load is very high. The surface of the metal frame foundation is made larger than the surface of the building on it to distribute the pressure over a larger surface.

Balanced footing foundation

To prevent the rotation of the beam and the foundation, or in the vicinity of the neighboring wall, balanced footing foundation or stafdansionum is used.

Curled foundation

The connection of two spring foundations using reinforced concrete is called coiled foundation. In earthquake-prone areas, it is considered the best type of foundation for ordinary residential buildings. If the thickness of the foundation is less than the height of the foundation, it is connected in two ways:

The upper surface of the shingle and the upper surface of the metal frame foundation are aligned.

The surface of the underlay is aligned with the bottom surface of the metal frame foundation.

Pile foundation

Piles are members made of steel, concrete, reinforced concrete and wood, which are used for foundation construction if the bearing capacity of the ground is not suitable. When the upper layers of the soil have strong or very weak compressibility, so that it is not possible to use the surface foundation to distribute the load of the building, pile foundations become more difficult to transfer the load to the lower layer.

When the rock bed or bottom solid layer is not placed at a suitable depth from the ground surface, piles are used to gradually transfer the load. In this case, most of the resistance of the pile is provided through the friction force between the contact surface of the pile and the soil. If piles are subjected to horizontal force, they can carry horizontal forces by bending while being capable of carrying vertical loads. This situation usually occurs in the foundation of the soil-retaining metal frame, whose function is to resist the lateral pressure of the soil, or in high-rise buildings that are affected by the force of wind or earthquakes.

The stages of implementation of steel frame foundation

The most common construction methods around the world are three construction methods with building materials, steel frame and concrete frame. Steel frame consists of metal beams and columns. Steel frames serve as an alternative to traditional wooden frames and offer many advantages to both builders and buyers. Steel frame construction is usually used in high-rise, industrial, warehouse, residential, etc. buildings.

Due to its important advantages, steel is the most basic material used in the steel frame. The most important advantages of the steel frame are:

high resistance

reaction

homogeneity

Welding capability

flexibility

The use of metal framework in structures reduces the weight of the building. It also has high resistance and strength against any impact, pressure and external factors.

The stages of implementation of the steel frame foundation

The foundation is an important and important part of the structure, and every stage of the implementation of the steel frame foundation

must be done with great care and attention. If the foundation is implemented without complying with international standards, the building will face many problems that can be dangerous for the building's occupants. The most important point in the correct implementation of the foundation is the equal distribution of the load of the structure and its transfer to the ground. Before the implementation of the foundation, it is necessary to check the ground and soil of that area to ensure the strength and resistance for the implementation of the foundation.

The steps of foundation implementation are as follows:

Excavation

Excavation is the first step in the implementation of the metal frame foundation. At this stage, obstacles such as stones and lumps or low and high points on the ground are removed and the uneven ground is smoothed. Also, in places where there are holes and pits, embankment is done to create a smooth surface. After embankment, water is poured on the ground and the ground is compacted well so that it is ready for excavation.

Place the foundation plan on the ground

This step is done after excavation. First, they determine the geographic north and match it with the foundation map. An axis defines the longitudinal or transverse foundation and the rest of the map is executed based on this axis.

Excavation of the foundation site

The pitting stage is particularly important in the stages of skeleton implementation. For excavation, soil conditions such as adhesion of soil particles, compressive strength, and the amount of underground water are checked in laboratory environments. Then the soil height is measured.

In excavation, the walls of the pit may collapse during work, and to prevent this from happening, the walls of the pit are piled up and reinforced. Excavation can also be done step by step. For example,

the columns can be excavated first, and after placing the columns, the rest of the excavation can be done.

Implementation of lean Concrete

Concrete, like other types of concrete, is a combination of sand, water and cement, but it is only used for foundations due to its lack of strength. About 10 to 15 cm of concrete is used to separate the main foundation from the ground.

Reinforcement

One of the other steps of foundation implementation, which is particularly sensitive, is reinforcement. This step should be placed on the foundation according to the plan, and their distance from the concrete should be about 4 cm.

Foundation molding

This step is done after strengthening. To perform molding, it is necessary to ensure that the boards used are healthy, flat and without knots. The installation of the boards should be such that it is possible to drain excess water from under or around them. They must also be able to hold the concrete as it is and protect it from damage, vibration, cold and heat. An important thing to know about formwork is that the wood or metal boards used can be removed after drying without damaging the concrete.

Implementation of the base plate

The foundation plate is a plate placed under the column and its task is to distribute the load of the column on the foundation. There are holes around the foundation plate that are used to connect the armature. There is also a hole in the center to allow excess air to escape during ventilation.

There should be no air under the plates to prevent the columns from settling on the ground. For this reason, the foundation plate should be placed in place and filled with loose concrete and well ventilated by tightening the screws.

Concreting

The implementation of concrete must be done simultaneously and coordinated. Concrete should cover all parts of reinforcement and

foundation. Be sure to mix and mix the concrete several times in the truck mixer before spraying.

After mixing, in order to prevent concrete deterioration and separation of particles, concrete should not be sprayed from a distance, and it is better to pour it in the form of a shot (a type of special stud) in the desired location.

Implementation of steel structure

The metal frame should be done after the foundation is completed. According to the plan designed for the structure, the location of the columns is determined and the columns are built in place. As soon as the columns are placed, the beams are fixed in place, and so are the rest of the components of a structure executed according to the plan. The strength of the skeleton depends on the correct implementation of the foundation because it supports the weight of the skeleton and by dividing the pressure caused by the metal skeleton on the ground, it prevents subsidence and its consequences.

Comparison of concrete and steel structure

Concrete and steel structures have many differences. One of the most important of them is the implementation cost. Considering that they consist of many steel sections, steel frames have a higher implementation cost than concrete frames. Since the execution time of metal frame projects is less and the floors can be executed simultaneously, the exorbitant costs of this type of structure are compensated to some extent.

Also, one of the other differences between the two is the implementation of tall buildings with metal frames because they weigh less than concrete frames. Therefore, they are the best option for steel implementation of long and tall structures.

Steel frames are made of beams and columns that are connected to each other with screws, rivets or welding. The implementation of the structure with metal infrastructure helps a lot to reduce the

weight of the structure. It is also resistant to any impact and pressure.

At the same time, the exorbitant costs of these types of structures are compensated to some extent. Also, one of the other differences between the two is the implementation of tall buildings with steel frames because they weigh less than concrete frames. Therefore, they are the best option for the implementation of long and tall structures.

Steel frames are made of beams and columns that are connected to each other with screws, rivets or welding. The implementation of the structure with metal infrastructure helps a lot to reduce the weight of the structure. It is also resistant to any impact and pressure. The stages of the implementation of the metal frame foundation, respectively, include excavation, implementation of the plan, excavation, implementation of concrete, reinforcement, molding, implementation of the foundation plate and finally placing the columns and beams. Metal and concrete skeletons have differences, of which implementation costs are one of the most important.

Chapter Three

Building standard

Developed by the International Organization for Standardization (ISO) for the building construction industry, ISO standards help organizations cover every part of the project completion process from floor to roof. The construction industry is one of the most profitable and competitive industries. To successfully implement projects, construction companies must run an efficient operation, one that is proactive about safety and sustainability and flexible enough to respond to the evolving demands of the industry.

Obtaining ISO certification by contractor companies operating in this field is one of the best investments that a construction company can make. Accredited construction contractors have internal credibility that helps them grow their business, reduce compliance and liability risks, and generally follow their work processes more effectively.

In order to participate in the tender, construction companies can obtain a contractor qualification certificate (building rating), a contractor qualification certificate (facility rating) and a contractor safety qualification certificate. However, contractor companies operating in the construction industry must obtain the relevant ISO certificate. ISO certificates related to building construction can be classified into two categories: general ISO certificates and specialized certificates related to the construction industry.

This International Standard specifies a range of requirements and recommendations for the many construction elements, assemblies, components and connections that make up the built environment. These requirements relate to the construction aspects of access to buildings, circulation within buildings, egress from buildings in the normal course of events, and evacuation in emergencies. An informative primer is also included that addresses aspects of access management in buildings.

This International Standard contains provisions regarding features in the external environment that are directly related to access to a building or a group of buildings from the edge of the boundary of the relevant site or between these groups of buildings in a common location. This International Standard does not deal with elements of the external environment, such as public open spaces, whose function is independent and unrelated to the use of a particular building, and other than circulation spaces, it does not address single-family homes. and appliances that are common in two or more houses.

User restrictions

This regulation is used for the design and implementation of reinforced concrete, metal, wooden buildings and buildings with construction materials.

The following buildings are not covered by this regulation:

A: Special buildings such as dams, bridges, wharves and marine structures and nuclear power plants.

In the design of special buildings, special criteria that are determined in the regulations for each of them to deal with the effects of earthquakes must be observed. In any case, the acceleration according to the plan should not be considered less than the value stated in this regulation. In cases where special studies are conducted regarding building seismicity for these types of buildings, its results can be used as a criterion for action, provided that the

values of the spectrum of the special design of the building are not less than two-thirds.

B: Traditional buildings that are built with mud or clay.

Due to the weak materials, these types of buildings do not have much resistance against earthquakes, and even ensuring their safety against earthquakes requires special measures. Considering that in desert and remote areas, it is not easily possible to obtain resistant materials, there must be specific technical criteria and instructions to ensure their relative safety by using resistant elements of wood, metal, concrete, polymer or a combination of them or anything. There is another. Materials. Develop, promote and implement.

Reinforced brick buildings and reinforced cement block buildings, in which construction materials are used to withstand pressure and metal bars to withstand tension, are subject to the rules and regulations of the second chapter of the 2800 standard. The design of such buildings should be based on the valid regulations of one of the other countries until special regulations are formulated.

Geotechnical considerations

In general, it should be avoided to build a building on active faults where there is a possibility of the ground breaking during an earthquake. In cases where the construction of the desired building is at fault, in addition to complying with the rules of this regulation, special technical measures must also be taken.

Architectural considerations

The plan of the building should be as simple and symmetrical as possible in two perpendicular directions and without much setback, and asymmetric changes of the plan in the height of the building should be avoided as much as possible.

Even if possible, the construction of towers larger than 1.5 meters should be avoided.

Do not create large openings adjacent to each other in the diaphragm of the floors.

Avoid placing construction components, installations or heavy goods on towers and thin elements and large openings.

By using structural materials with high strength and suitable plasticity and non-structural light materials, the weight of the building was minimized.

As much as possible, avoid creating level differences in the floors.

Avoid reducing and increasing the floor level in height to create significant changes in the mass of the floors.

Considerations for the foundation of the structure

The elements that bear the vertical load should be stacked as much as possible on different floors so that the load of these elements is not transferred to each other through the horizontal elements.

The elements that bear the horizontal forces caused by the earthquake should be considered in such a way that the forces are transferred directly to the foundation and the elements that work together are placed in a vertical plane.

The elements resistant to the horizontal forces caused by the earthquake should be considered in such a way that the twisting caused by these forces in the floors is minimized. For this purpose, it is suitable that the distance between the center of mass and the center of stiffness in the floors is less than 5% of the length of the building.

The building and its components should be designed in such a way as to ensure proper plasticity in them.

In buildings where a flexural frame system is used for lateral load, the design should be done in such a way that as much as possible the columns fail later than the beams (strong column-weak beam).

Non-structural members such as walls and internal facades should be implemented in such a way that during an earthquake they do not disturb the movement of structural members as much as possible. Otherwise, the impact of the interaction of these members with the structural system should be considered in the analysis of the structure.

Avoid creating short columns as much as possible.

general rules

All the elements of the building must be properly connected to each other so that during an earthquake, the different elements are separated from each other and the building functions in a unified manner. In this case, the floors should be properly connected to the vertical load-bearing elements, frames or walls so that they can transfer the forces caused by the earthquake in the form of a diaphragm to the lateral load-bearing elements.

The building must withstand the horizontal forces caused by the earthquake in both horizontal extensions perpendicular to each other, and in each of these extensions, the horizontal forces must be properly transferred to the foundation.

The minimum width of the cut seam in each floor is equal to one hundredth of the height of that floor from the foundation level. To ensure this purpose, the distance of each floor of the building from the border of the adjacent land (if its ownership is different) must be at least five thousandths of the height of that floor from the foundation level. The gap between the gap can be properly closed with low-resistance materials that are easily crushed when two buildings collide during an earthquake, so that it can be easily replaced and improved after the earthquake.

Grouping of buildings based on importance

Group 1-

A- very important buildings

In this group, there are buildings whose usability after an earthquake is of particular importance and the interruption in their operation indirectly increases casualties and damages, such as hospitals and clinics, fire stations, water supply centers and facilities, power plants and electricity supply facilities, airport control towers, telecommunications, radio and television centers, military and law enforcement facilities, justice and prisons, relief centers and in general all buildings that are used

in rescue and relief It is effective. Buildings and facilities whose damage causes the widespread release of toxic and

harmful substances for the environment in the long term are included in this group of buildings.

Group 1- Other "very important" buildings

Other buildings of the "very important" group include the following three categories:

B: Buildings whose damage causes many casualties, such as schools, mosques, stadiums, cinema and theater halls, meeting halls, department stores, passenger terminals or any covered space with more than 300 people under it. They gather under one roof.

A: Buildings whose destruction causes the loss of national wealth, such as museums, libraries, and generally centers where national documents or valuable works are kept.

D: Buildings and industrial facilities whose damage causes environmental pollution or widespread fire, such as refineries, fuel warehouses and gas supply centers.

Group 2- Buildings of medium importance

This group includes all the buildings included in this regulation, except for the buildings mentioned in other groups, such as residential, office and commercial buildings, hotels and multi-story parking lots, workshop warehouses, industrial buildings, etc.

Group 3- "low important" buildings

This group includes the following two categories:

A- Buildings that cause relatively little damage due to their failure and the probability of loss of life is very low in them, such as agricultural warehouses and poultry farms.

B- Temporary buildings whose operation period is less than 2 years.

Grouping buildings based on structural system

Buildings are classified according to the structural system in one of the following groups:

Bearing wall system

It is a type of structural system that lacks a complete building frame system for vertical load. In this system, load-bearing walls or braced frames mainly bear vertical loads, and resistance to lateral forces is provided by the same load-bearing walls that play the role of shear walls or braced frames.

Simple building frame system

It is a type of structural system in which vertical loads are mainly supported by complete building frames with joints, and resistance to lateral forces is provided by shear walls or braced frames. The frame system with horizontal connections (or stirrups) along with vertical braces are also from this group.

Moment frame system

It is a type of structural system in which vertical loads are supported by complete building frames and resistance to lateral forces is provided by bending frames. Full bending spatial structures or structures with bending frames around or in a part of the plan along with frames with simple joints in other parts of the plan are from this group.

In this system, concrete and metal bending frames can be designed in a normal, medium or special way.

Dual or combined system

It is a type of structural system in which:

A-Vertical loads are mainly supported by complete building frames.

B-Resistance to lateral loads is provided by a set of shear walls or braced frames together with a set of bending frames. The shear contribution of each of the two sets is determined according to the lateral stiffness and the mutual effect of the two in all floors.

C-Each of the two sets of shear walls or braced frames and bending frames can independently withstand at least 25% of the lateral forces introduced into the building.

In buildings shorter than eight stories or less than 30 meters in height, instead of distributing the load based on the stiffness of the lateral load-bearing elements, shear walls or braced frames can be used for 100 percent of the lateral load. The set of bending frames is designed for 30% lateral load. The use of ordinary concrete and metal bending frames for lateral load is not allowed in this system, and if this type of structure is used, the system is considered simple.

Benefits of certification for the construction industry

ISO designed each of the above standards to be broadly applicable to any organization, regardless of industry. Each includes a set of repeatable processes and metrics to monitor performance and initiate a cycle of continuous improvement. While every organization is different, there are several concerns for the construction industry that standardization can help address. This includes:

- **Injury prevention:** The International Labor Organization (ILO) estimates that 2.78 million workers die each year as a result of occupational accidents or diseases. In addition, 374 million non-fatal work-related injuries and illnesses increase the economic and human costs of inadequate health and safety management. ISO 45001 is one of the most important standards for the construction industry, as it provides a proactive framework for preventing and responding to health and safety incidents.
- **Efficiency and accuracy:** ISO standards can help construction companies run a cost-effective business and deliver on their promises to customers. ISO 9001 improves predictability. Transparency and internal communication will help you get jobs without affecting the quality of the work you do. Equally important, it provides a high-level framework for reconciling other concerns – health and safety, energy consumption and asset management – including in line with your wider business objectives.
- **Regulatory compliance:** As regulations on energy use and green building become more stringent, both government agencies and

private companies will seek partners with proven credentials in these areas. ISO standards such as ISO 14001 and ISO 50001 are

recognized and accepted worldwide. They provide an effective way for contractors to meet compliance requirements and grow their business in new regions and territories.

Working with NQA

NQA can assist in construction industry certification and training related to ISO and other standards.

Standard types of buildings

The global construction industry is one of the most lucrative and competitive industries. To successfully implement projects, construction companies must run an efficient operation, one that is proactive about safety and sustainability and flexible enough to respond to the evolving demands of the industry.

Certification to any of the many ISO standards is one of the best investments a construction company can make. Certified construction contractors have built-in credentials that help them grow their business, reduce compliance and liability risks, and generally run leaner, more responsive operations.

The construction industry is multifaceted and includes contractors, subcontractors, architects, engineers, designers, suppliers, and other professionals in the private, government, and military sectors. Depending on the nature of your organization, any of several standards may be relevant, including:

- ISO 9001 - the international standard for quality management - is one of the most common ISO systems in the world
- ISO 14001 - international standard for environmental management systems
- ISO 50001 - the international standard for energy management systems, and ESOS, a mandatory energy assessment scheme for large UK-based organisations.
- ISO 45001 - the international standard for safety and health management, which replaces the old OHSAS 18001 system.

- ISO 44001 - International standard for collaborative work

ISO 9001:2015 quality management systems

ISO 9001 is defined as an international standard that specifies the requirements for a quality management system (QMS). Organizations use this standard to demonstrate their ability to consistently deliver products and services that meet customer and regulatory requirements. This standard is the most popular standard in the ISO 9000 series and the only standard in this series that organizations can certify to.

ISO 9001 was first published in 1987 by the International Organization for Standardization (ISO), which is an international agency consisting of national standards bodies from more than 160 countries. The current version of ISO 9001 was published in September 2015.

What topics does ISO 9001:2015 cover?

ISO 9001 is based on the methodology of action planning and provides a process-oriented approach for documenting and reviewing the structure, responsibilities and procedures required to achieve effective quality management in an organization. Certain sections of the standard contain information on many topics, such as:

- The requirements of a QMS, including documenting information, planning and specifying process interactions
- Management responsibilities
- Management of resources, including human resources and the work environment of an organization
- Product realization, including stages from design to delivery
- Measure, analyze and improve the QMS through activities such as internal audits and corrective and preventive actions

Benefits of ISO 9001 for construction

ISO 9001 quality management systems are the standard used by organizations around the world to reduce costs, provide better customer service, and ultimately win, delight, and retain customers.

It is based on several principles of quality management, including a strong customer focus, top management motivation and commitment, a process approach, and continuous improvement.

Due to the complexity of construction projects that often involve multiple moving parts, having an effective quality management system is essential to project success. ISO 9001 quality management systems certification helps you manage your supply chain. Almost all companies in the construction sector rely heavily on subcontractors and need them to work together as part of a team. ISO 9001 quality management systems certification will help you manage your subcontractors on an ongoing basis and ensure that appropriate processes and procedures are in place and that controls are effectively managed. Having a process for regularly monitoring your list of approved suppliers is part of the standard. It is very important to periodically audit the suppliers and contractors you work with to ensure the overall quality of service in your organization. This standard provides an excellent framework for evaluating supplier performance through its relationship management principles. Using the standard gives you a fair and transparent way to evaluate your partnership's performance. Ultimately, this gives you a competitive advantage by streamlining processes.

What is ISO 14001:2015 Environmental Management Systems?

ISO 14001 is an international standard that specifies the requirements for an effective environmental management system (EMS). Rather than specifying environmental performance requirements, it provides a framework from which an organization can build upon.

Part of the ISO 14000 family of environmental management standards, ISO 14001 is a voluntary standard that organizations can adopt. Integrating it with other management systems standards, typically ISO 9001, can further help achieve organizational goals.

The International Organization for Standardization (ISO) defines an environmental management system as "the part of a management

system used to manage environmental aspects, meet compliance obligations, and address risks and opportunities." The ISO 14001 standard framework can be planned in a planning approach. Do-Check-Act PDCA used for continuous improvement.

What topics does ISO 14001:2015 cover?

At the highest level, ISO 14001:2015 covers the following topics with respect to environmental management systems:

- The context of the organization
- Leadership
- planning
- Support
- Action
- performance evaluation
- Improvement

ISO 14001 environmental management systems framework (EMS)

14001:2004 vs. 14001:2015

The 2015 edition of ISO 14001 introduces a number of changes compared to previous editions. A review of 20 years of research on this standard is available to ASQ members.

As part of the effort to structure all ISO standards in the same way, revisions to ISO 14001:2015 include combining the high-level structure, using mandatory definitions, and combining the requirements and clauses of common standards.

Integration of ISO 9001 and ISO 14001

Consolidation of management systems standards can increase focus while reducing the likelihood of confusion. ISO 9001 elements can be augmented with corresponding ISO 14001 components.

Responsibilities of hybrid standards may include:

- Drafting a policy statement and measurable goals
- Setting organizational charts and job descriptions
- Provision of sufficient resources
- Document management for both standards in a single document control system
- Determining the management representative and coordinator of quality and environment management systems

When adding ISO 14001 components to ISO 9001 components, planning must be expanded to address environmental impacts and inspection and testing systems modified to cover environmental compliance. The organization must meet the environmental expectations of customers and the government and must include elements of environmental management in internal audit programs and training sessions.

ISO 14001 can be integrated with standards in addition to ISO 9001 to create synergy with other systems such as OHSAS 18001 and ISO 13485.

ISO 14001 certification

Organizations that have already received ISO 14001 certification are encouraged to move to the 2015 version. Organizations will have a three-year transition period to update their environmental management systems to the new standard.

To get started with ISO 14001:2015

- Checking the existing requirements of the quality management system (ISO 9001:2015)
- Purchase ISO 14001:2015
- Get ISO 14001 training
- ISO 14001 certificate

The ISO 14001 standard: a literature review and research agenda based on the theory of environmental sustainability quality

management journal has gained momentum in the world of business and academia. After nearly 20 years of research in this field, this paper presents a holistic literature review specifically focused on ISO 14001, which is widely considered the most important environmental certification.

Stewardship and Sustainability: Serigraph's Journey to ISO 14001
Journal for Quality and Engagement Serigraph's leaders understand that sustainability and social responsibility require the simultaneous promotion of equitable economic growth, environmental protection and social well-being. Serigraph uses ISO 14001, Six Sigma and Lean as its models for environmental improvement and sustainability.

ISO 14001 in construction industry

Environmental management systems

Creating an environmental policy, identifying environmental effects, defining goals and objectives leads to improving the environmental behavior and performance of organizations.

The ISO 14001:2015 standard focuses on compliance with environmental issues of organizations, improving environmental performance, as well as reducing, managing and preventing environmental and environmental pollution. This standard is not created as an environmental performance control, in fact, following progress in environmental issues.

The environmental management system, in addition to the advantages it has in the environmental management of organizations, also reduces the costs of disposal, handling and transportation of waste. We can also see a better use of raw materials.

Many cases dedicated to monitoring compliance with environmental requirements consider the implementation of an environmental management system and its validation. It improves and complies with various laws and regulations, enabling access to permits and concessions in environmental matters.

Environment and construction

For the construction industry, one of the most important points that must be observed, planned and considered is the environmental aspects, because any project of this kind changes, changes and can even affect the environment, the surrounding environment and the place where the new project is located. It is placed in it, to harm. stay on; which should be avoided by having a proper planning and also a good identification of possible risks.

For a construction company, in addition to being useful, it allows you to have an environmental policy that you must adhere to, obtain and maintain. It also allows you to define and identify your significant environmental impacts, applicable legal requirements, mandatory resources, processes, procedures, and accordingly define and implement your company's goals.

One of the best ways to comply with all relevant points in a construction project is to have a developed and approved environmental management system. In this industry, the issue of pollutant emissions, which must be controlled and examined within the framework of the environmental management system, is of great importance, because it can bring sanctions and penalties.

ISO 45000 (occupational health and safety)

For organizations that are serious about improving employee safety, reducing workplace hazards, and creating better and safer working conditions, ISO 45001 exists.

According to the International Labor Organization, more than 7,600 people die every day due to work-related accidents or diseases. That is why an ISO committee of occupational health and safety experts is working to develop an international standard with the potential to save nearly three million lives a year. Similar in structure to other ISO management systems, this approach will be familiar to users of standards such as ISO 14001 or ISO 9001. ISO 45001 builds on the success of previous international standards in this field such as

OHSAS 18001, ILO-OSH guidelines, various national standards and ILO international labor standards and conventions.

ISO 45001

The recently published ISO 45001 is the world's first international standard that addresses occupational health and safety (OH&S). Designed to support organizations, reduce risk and promote occupational health, the ultimate goal of ISO 45001 is to: To help organizations provide safe and healthy work environments for their workers and other people related to the work environment.

ISO 45001 in construction

ISO 45001 is well suited to the construction industry and supports many aspects of the Construction Design and Management Regulation (CDM 2015) which emphasizes OH&S responsibilities.

Complying with the international standards of quality and environmental management (ISO 9001 and ISO 14001, ISO 45001) puts the responsibility of occupational health and safety on the top people and embeds occupational health and safety in the entire organization. More importantly, organizations It forces them to understand how the OH&S system affects them and not only employees, but also subcontractors, outsourced operations and other stakeholders. Workers of all types need to be involved and have input into OH&S decisions that affect them. They form an essential part of hazard identification and management of OH&S risks and opportunities.

ISO 45001 also considers the "world" in which you operate and the internal and external factors that affect it. Organizations, known as "fields", need to look beyond their industry and determine what society as a whole expects of them.

The new standard means that health and safety becomes an integral part of the management process and creates a culture of integrity, consistency and continuous improvement where health is a central aspect of the workplace.

HSE-MS standard

HES-MS management system derived from the first letters of the phrase:

HES-MS means health, safety and environment management system. The purpose of creating the HSE management system is to provide a targeted method based on the existing standards to ensure that potential and actual risks in the field of health, safety and environment are accurately determined, eliminated or controlled.

The health, safety and environment management system is part of the overall management system of the military company. It is purposeful and organized with special planning which is established and reviewed by the preparation of guidelines, executive methods and instructions, executive methods and current standards and regulations, and revised at different times. The HSE management system may be a part of a general management system, but in fact this system is also related to the same general management system and just for the sake of simplicity, it is referred to as the HSE management system everywhere.

The HSE management system is the main and necessary elements for the development, establishment and maintenance of a system, which requires companies to establish the policies and goals of the organization by taking into account information about important risks and environmental effects.

The organization must establish strategic health, safety and environmental goals and review them periodically. These goals must be compatible with the organization's policy and reflect the results of activities, risks and impacts of health, safety, environment, commercial and operational requirements, opinions of employees, customers and subsidiary companies.

Other requirements of the HSE management system: preparing a written policy that is available to everyone. The policy should be printed and framed in the watchtower.

CRM

Customer relationship management (CRM) is the process by which a business or other organization manages its interactions with

customers, typically using data analytics to study large amounts of information.

CRM systems collect data from a range of different communication channels, including the company's website, telephone, email, live chat, marketing materials and, more recently, social media. They allow businesses to learn more about their target audience and how to best meet their needs. earn, so they retain customers and increase sales. CRM may be used with past, present or potential customers. The concepts, procedures and rules that a company is based on when communicating with its customers are called CRM. This complete communication covers direct contact with customers, such as sales and service-related operations, forecasting and analyzing consumer patterns and behaviors from the company's perspective. According to Gartner, the global CRM market size is estimated to be \$69 billion in 2020.

5S

5S is a workplace organization method that uses a list of five Japanese words: seiri (整店), seiton (整頓), seisō (意游), seiketsu (游法) and shitsuke (躰). These are translated as "arrange", "in order", "shine", "standardize" and "sustain". This list describes how to organize a work space for efficiency and effectiveness by identifying and storing used items, maintaining the area and items, and maintaining the new organizational system. The decision-making process usually consists of A conversation about standardization ensues, creating an understanding among employees of how work is done.

5S methodology



5S at the Scanfil Poland factory in Sieradz.

Apart from being a specific stand-alone methodology, 5 S is often recognized as an element of a broader structure known as visual control, visual workplace, or visual factory. Under those terms (and similar, Western companies used the basic concepts of 5S before the publication, in English, of the official 5S method. For example, a workplace organization photo from Tennant Company (a manufacturer based in Minneapolis, exactly like the photo accompanying this article, appeared in a 1986 production management book.

The roots

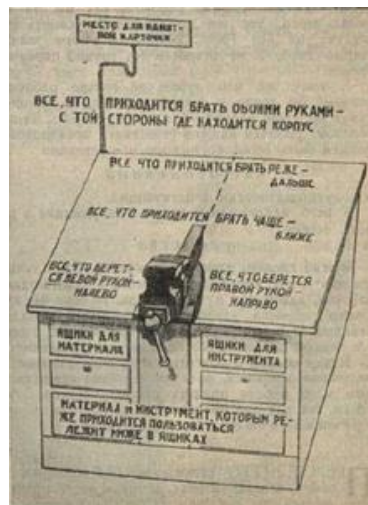

Scheme "Correct arrangement of tools" from the instruction sheet of the Central Labor Institute of the USSR, 1920-1924

5S was developed in Japan and is recognized as one of the techniques that enabled Just in Time production. Two main frameworks for understanding and applying 5S in business environments have been developed, one by Takashi Osada and the other by Hiroyuki Hirano.

Hirano proposed a structure for improving applications with a series of identifiable steps, each building on its predecessor.

Prior to this Japanese management framework, a similar "scientific management" was pioneered by Alexei Gastov and the Central Labor Institute of the Soviet Union (CIT) in Moscow.

Variety of programs

The 5S method has expanded from manufacturing and is now used in a wide variety of industries, including healthcare, education, and government. Visual management and S5 can be especially useful in healthcare, as the frantic search for supplies to treat a troublesome patient (a chronic problem in healthcare) can have disastrous consequences. Although the origins of the S5 method are in manufacturing, it can also be applied to The knowledge economy is applied with information, software or media in place of a physical product.

In product development

The output of engineering and design in a lean information company, the theory behind the use of 5S here is: "Dirty, cluttered or damaged surfaces attract the eye, which spends a fraction of a second every time we look. Extracting useful information from them." Old equipment obscures new equipment, leaving people wondering which to use.

Standard - SEIKETSU

This aspect of S 5 focuses on standardization and makes the three S's, Seiri, Seiton and Seiso, a consistent routine. Here the emphasis is on intuitive management, an important aspect to achieve and maintain standardized conditions to enable people to always be fast. This is a call to systematize the above 3S practices. This means ensuring that whatever neatness and order is achieved must be maintained.

SUSTAIN – SHITSUKE

Shitsuke emphasizes the ability to create a workplace with good habits and discipline. Showing others what to do and encouraging practice among them. This is mainly a management responsibility.

Sustain also means "discipline". It shows your commitment to maintaining discipline and practicing S3 as a way of life. It also

requires that your employees show positive interest and overcome resistance to change.

ISO 12944 Corrosion protection of steel with protective paint

An abundant resource in industry due to its reliable support and anti-rust properties, steel is one of the most common metals on the planet. However, as a ferrous metal, it is susceptible to corrosion through simultaneous exposure to moisture and oxygen. When the iron in steel oxidizes, it takes up about six times the volume of the original material, which can severely compromise its structure. Protecting steel against corrosion is essential to ensure its longevity, a task standardized through ISO 12944.

ISO 12944 standard

ISO 12944 deals with a protective paint system that can prevent corrosion in carbon or low alloy structural steel. This coating system delays the corrosion of the metal because it can separate the steel surface from the local microclimate that surrounds it and would otherwise cause rusting. ISO 12944 consists of eight sections, each of which addresses specific considerations or covers a step of the process in depth.

All ISO 12944 parts

ISO 12944-1:2017 – Paints and corrosion – Corrosion protection of metallic framework by protective paint systems – Part 1: General introduction does not define a specific method, but rather provides the background required for the use of collective documents. This standard defines the scope of the standard and specifies that it is used only to prevent corrosion and not to protect the associated surface against other forces such as microorganisms, chemicals, mechanical actions and fire.

Based on this, ISO 12944-2:2017 - Paints and corrosion - Corrosion protection of steel framework by protective paint systems - Part 2: Classification of environments classifies the main environments to which structural steel can be exposed. It defines categories of atmospheric corrosion based on mass loss, describes environmental

categories for structures submerged in water or buried in soil, and provides information on some specific corrosion stresses.

As an initial step in the protective paint process, ISO 12944-3:2017 - Paints and corrosion - Corrosion protection of metallic structures by protective paint systems - Part 3: Design considerations requires that steel structures be designed that not only ensures their overall support, but also facilitates the preparation, application and maintenance of protective paint. Since some structural forms are more susceptible to corrosion, it is recommended that the designer contact a corrosion specialist in the early stages so that the structure does not suffer from corrosion before implementation.

ISO 12944-4:2017 – Paints and corrosion – Corrosion protection of steel structures by protective paint systems – Part 4: Types of surface and surface preparation defines a number of types of surfaces of steel structures and the requirements for It provides their preparation for the application of paint.. These requirements ensure that the surface is free of any harmful substances that can limit the adhesion of the primer to the steel.

ISO 12944-5:2019 – Paints and corrosion – Corrosion protection of steel frame by protective paint systems – Part 5: Protective paint systems focuses on the other main component of a protected structure: the paint system itself. This section describes the different types of paints and coating materials and provides guidance for their selection based on the classification of environments and surfaces established by the previous sections of the collective standard.

The final section is ISO 12944-6:2018, a guide to paint system selection – Paints and corrosion – Corrosion protection of metallic structures by protective paint systems – Part 6: Laboratory performance test methods. This document addresses the laboratory test methods used to determine the success of a specific protective paint system. One of the methods discussed to aid in the selection of a paint system is synthetic foundation to estimate the reliability of the anti-corrosion application over time.

ISO 12944-7:2017 – Paints and corrosion – Corrosion protection of steel structures by protective paint systems – Part 7: Application and monitoring of paintwork deals with the actual application of

protective paint systems on steel frames and the requirements for It expresses it. Implementation, in addition to color management and

workers. It is recommended that the steel substrate be prepared for the application of the paint system with a foundation based on the instructions given in the previous six parts of the standard.

And finally, at least for the broader guidance covered by this series of standards, ISO 12944-8:2017 - Paints and corrosion - Corrosion protection of metal frameworks by protective paint systems - Part 8: Development of specifications for new work and maintenance of tools that By means of which the protected steel can be maintained throughout its useful life.

Focusing on a specific group of structures, the final standard in this series, ISO 12944-9:2018 - Paints and corrosion - Corrosion protection of metallic structures by protective paint systems - Part 9: Protective paint systems and methods Laboratory Performance Tests for Offshore and Related Structures specifies the performance requirements of protective paint systems for marine structures. These requirements, which also apply to other structures in marine atmospheres and structures submerged in sea or salt water, are exposed to environments of marine corrosiveness class CX and immersion class Im4 according to ISO 12944-2. This standard describes paint systems for high durability based on ISO 12944-1.

ISO standards related to building construction, general standards

The construction industry is multifaceted and includes contractors, subcontractors, architects, engineers, designers, suppliers, and other professionals in the private, government, and military sectors. Depending on the nature of your organization, any of several standards may be relevant, including:

ISO 9001:2015, the ISO 9001 standard is related to the quality management system and is part of the ISO 9000 standard family. From the ISO 9000 standard family, only the ISO 9001 standard can be certified. Therefore, the ISO 9001 standard is one of the most common ISO standards in life. Companies operating in the building construction industry can apply for ISO 9001 certification.

ISO 14001:2015, the ISO 14001 standard is part of the ISO14000 family of standards that address environmental management system

issues. Environmental destruction or environmental pollution for building construction can be one of the most destructive foundations of this industry. Therefore, companies can apply for ISO 14001 certification to demonstrate their commitment to environmental protection.

ISO 45001:2018, the international standard ISO 45001 that replaced OHSAS 18001, describes the occupational health and safety quality management system. Maintaining the occupational safety of construction workers and occupational health is one of the most important activities of construction contractors. Therefore, you can demonstrate your commitment to the health, safety and well-being of construction workers by obtaining ISO 45001 certification.

ISO 50001:2018 is the international standard for evaluating energy management systems and Iran's environmental organization ISO 50001. The ISO 50001 standard can be a mandatory assessment plan for the energy conservation of buildings that may be requested from companies by government authorities. Therefore, by receiving the ISO 50001 certificate, construction companies can express their commitment to create an energy management system.

ISO 44001:2017 is a management system standard for business and working relationships shared between different groups. The ISO 44001 standard specifies requirements for effectively identifying, developing and managing collaborative business relationships within or between organizations.

ISO 3881:1977 standard

The ISO 3881 standard is one of the ISO standards related to building construction and the coordination between the dimensions of the stairs and the opening of the building stairs. The international standard ISO 3881 was developed by the ISO Technical Committee ATC 59, Technical Committee for Building Construction and has been able to issue certificates since 1977. Therefore, contracting companies such as construction, design, engineering, etc. can obtain ISO 3881 certification.

ISO 2848:1984 standard

The international standard ISO 2848 is one of the ISO standards related to building construction that applicants can apply for ISO 2848 certification. The ISO 2848 standard specifies general principles and criteria for determining the dimensions of buildings and the location of dimensions, floor-to-ceiling equipment based on the objectives of modular coordination. International Standard ISO 2848 was developed by Technical Committee ISO/TC 59, Building Construction. The ISO 2848 certificate is issued to applicants by companies that issue ISO certificates.

ISO 9836:2017 standard

The ISO 9836 standard was published by Technical Committees ISO/TC 59 (Committee on Buildings and Civil Engineering Works) and SC15 (Committee on Identification of Frameworks for Describing the Performance of Housing) in 2011 and in 2017 the latest edition of ISO 9836 was published. Using the requirements of ISO 9836, the indicators The area and volume obtained from the measurement of spaces in buildings can be used to compare aspects of value, such as the proportion of space or volume that can be used functionally.

ISO 23045:2008 standard

The ISO 23045 standard provides guidelines for the design of the building environment to assess the building's energy efficiency. Applicants to implement ISO 50001 must follow the guidelines of ISO 23045 standard. The ISO 23045 standard was prepared by the Technical Committee ISO/TC 205 (Building Environment Design Committee) and published in 2008. Contractor companies that are active in the field of building construction can apply for ISO 23045 certification.

ISO 11855-1:2012 standard

The ISO 11855 standard was developed by the ISO organization and the technical committee ISO/TC 205 for the design of the

building environment. This standard is defined by 8 guidelines by the ISO organization, which include the following.

ISO11855-1:2012, guidelines for building environment design, installation and control of embedded radiant heating and cooling systems.

ISO11855-2:2021, ISO 11855 standard, Part II, specifies guidelines for determining heating and cooling capacity.

ISO 11855-3:2021 Part III of the ISO 11855 standard specifies design guidelines and dimensions for heating and cooling systems.

ISO 11855-4:2012, ISO 11855, Part IV, specifies guidelines for calculating the dynamic heating and cooling capacity of thermoactive building systems.

ISO 11855-5:2021, ISO 11855 part 5 standard specifies how to install heating and cooling systems.

ISO 11855-6:2018, ISO 11855 Part VI specifies how to control temperature in heating and cooling systems.

ISO 11855-7:2019, one of the most important ISO standards related to building construction, is ISO 11855 Part VII. This standard specifies guidelines for input parameters for energy calculations.

ISO 11855-8, this standard specifies guidelines for electrical heating systems.

ISO 16813:2006 standard

The ISO 16813 standard, prepared by Technical Committee ISO/TC 205 (Design of the building environment), addresses a general principle in the interior design of buildings. The design and layout of bathrooms, bedrooms, living rooms and kitchens is very important. ISO standard guidelines 16813 helps engineers or designers to design the interior of the building in the best possible way.

ISO 863:2008 standard

The most important issue in building construction is the materials and cement used in the construction process. The ISO 863 standard

defines guidelines for cement quality control testing. ISO 863 certification is recommended for cement plants to obtain CE

certification. ISO 29581-1:2009 Experimental analysis of cement for performance and stability in wet conditions.

ISO 15686-5:2017 standard

The ISO 15686 standard was published by ISO International Organization and Technical Committee ISO/TC 59 as well as SC 49 for the life cycle of equipment used in building construction. ISO 15686 is one of the ISO standards related to building construction that contractors in the field of building construction can apply for certification. The first part of the ISO 158686-1:2011 standard is related to the guidelines for reviewing the principles and general framework for defining and planning the useful life of the building.

ISO 13153:2012 standard

The ISO 13153 standard is a design process framework for energy saving residential and small commercial buildings. ISO 13153 certification can be obtained together with ISO 50001 certification.

The purpose of the building standard

The International Standard Organization (ISO) designed each of the above standards to be broadly applicable to any organization, regardless of industry. Each includes a set of repeatable processes and criteria for monitoring performance and The beginning of the cycle of continuous improvement. While every organization is different, there are several concerns for the construction industry that standardization can help address.

This includes:

Preventing injuries: The International Labor Organization (ILO) estimates that 2.78 million workers die each year as a result of occupational accidents or diseases. In addition, 374 million non-fatal work-related injuries and illnesses increase the human and economic costs of inadequate health and safety management. ISO 45001 is one of the most important standards in the construction industry, as it provides a proactive framework for preventing and responding to health and safety incidents.

Efficiency and accuracy: ISO standards can help construction companies run a cost-effective business and deliver on their promises to customers. ISO 9001 improves predictability. Transparency and internal communication will help you find a job without affecting the quality of the work you do. Just as important, it provides a high-level framework for aligning other concerns, such as health and safety, energy consumption, and asset management, with your broader business goals.

The construction standard and the importance of standard construction in society are becoming more visible every day. We are all well aware of the importance of implementing standard design principles in construction, especially in modern construction projects, and we know that the more we implement these principles and basics in more detail, the more mature and professional the result will be.

The Organization of Standards (ISO) has developed several standards in this field by gaining detailed knowledge of design and engineering principles as well as using the opinions of engineers and experts.

Scope of application of ISO 2848

ISO 2848 specifies the objectives of modular coordination and states the general principles and rules of the construction standard that should be applied in determining the dimensions of buildings and the location and dimensions of components, equipment and assemblies.

In this way, it allows us to provide building components with standard sizes so that they can be correctly placed at the installation site. It is quite affordable. This standard facilitates cooperation between designers, manufacturers, distributors and construction contractors and the use of standard building components in the construction of all types of buildings.

Objectives of ISO 2848

ISO 2848 is related to standardization and industrialization in the field of construction and industrial standards. If we provide building

components with standard sizes, they will be installed correctly on site. Therefore, the economic efficiency of the building is improved. Other goals of this international standard include the following:

Facilitates collaboration between designers, manufacturers, distributors and construction contractors.

It uses standard building components in the construction of all kinds of buildings.

It improves communication during the design phase, preparation of building plans and determining the size and location of each building component.

Checks the standard size of building components.

It provides the ability to interchange and replace components with any type of material, shape, or manufacturing method.

It speeds up the construction process by standardizing the installation and placement of building components.

It ensures the dimensional coordination between the installed components of the building (equipment, tanks and other devices) with other parts of the building.

Scope of application of ISO 9836

This document is intended for use in the following situations:

Specifying the geometric performance of the building and its spaces, for example in the design, procurement procedures, etc., or in the building regulations, if necessary, technical documents related to the performance of the entire building prepared by designers, contractors and builders. The amount of area that will not be effectively available for the placement of work, furniture, equipment, or for the circulation of a person.

Evaluating, comparing or controlling properties of a building that are related to its geometric performance.

Note: Although there are different methods of measuring area around the world depending on the country or the type of buildings, not all measurement methods are necessarily applicable due to the

inability to identify the actual area, for example, the method of measuring the center of the wall. Therefore, this document is only for practical use in measuring expertise.

Objectives and scope of application of ISO 23045

The objectives of the International Construction Standard are to assist designers and practitioners in collecting and providing useful data that are needed at various stages of the design process. It also has building specifications prepared by building designers.

This international standard applies to new buildings and is applicable to air conditioning equipment and heating installations in new buildings. It is assumed that the conditions of the indoor spaces are maintained within the comfort range with respect to temperature, humidity, air quality and light or conditions maintained to protect against freezing.

Objectives of ISO 11855

ISO 11855 series (Building environment design - design, measurement, installation and control of radiant heating and cooling systems installed in buildings includes the following sections:

11855 specifies the comfort criteria that should be considered in the design of interior radiant heating and cooling systems, because the main goal of the radiant heating and cooling system is to satisfy the thermal comfort of the occupants.

11855 provides steady state calculation methods for determining heating and cooling capacity. 11855 specifies the design methods and dimensions of radiant heating and cooling systems to ensure the heating and cooling capacity.

11855 presents a measurement and calculation method for designing thermally active building systems (TABS) for energy saving purposes, as radiant heating and cooling systems can reduce energy consumption and heat source size by using renewable energies.

11855 deals with the process of setting up the system to work as planned. 11855 shows an appropriate control method for radiant heating and cooling systems to ensure the maximum performance

desired at the design stage when the system is actually operating in a building. 11855 provides a calculation method for ISO 52031 input parameters.

Objectives of ISO 16813

ISO 16813 Design of the building environment, indoor environment, general principles The general design principles of the construction standard, taking into account a healthy indoor environment for occupants and the protection of the environment for future generations, are established. This international standard promotes an approach in which the various parties involved in building environmental design work together to provide a sustainable built environment. The goal is to provide unique features of the design process.

Provide constraints related to sustainability issues from an early stage of the design process, including the life cycle of the building and plant along with the ownership and operating costs that exist throughout the design process.

Evaluate the proposed design against reasonable criteria for indoor air quality, thermal comfort, acoustic comfort, visual comfort, energy efficiency, and HVAC system controls at each stage of the design process.

Creating iteration between design and evaluation decisions during the design process:

Building environment design includes architectural design related to environmental quality and effective controls. This international standard is applicable for the design of the building environment for new constructions and retrofitting of existing buildings.

Objectives of ISO 863

ISO 863 Cement, Test methods, Pozzolanic test for pozzolanic cements describes a method for measuring the pozzolanicity of pozzolanic cements.

Pozzolans are silicate-based materials that react with calcium hydroxide (lime produced by hydrated cement) and form additional

cementitious materials. The speed of cementation of cement-containing materials increases and increases cement adhesion.

The standard of building materials in Iran

Structures

Construction materials and products

Performance and energy sustainability

Fire safety

Information management in construction

Elevator and escalator

Life planning, durability and useful life

What is the valid certificate of product standard and construction material standard in Iran?

Rapid growth of world population and urbanization. It has created an increasing need for a high quality, safe and sustainable built environment. In the world of building and construction, standards help formulate international best practices and technical requirements to ensure that buildings and other structures (known as civil works) are safe. To know how the standard of building materials in Iran and what parameters it considers, stay with us.

Construction standards are regularly updated for climate change, demographics, and socially with input from all stakeholders involved, including architects, designers, engineers, contractors, owners, product manufacturers, regulators, policy makers, and consumers.

Industry

Standards help construction. The industry is more effective and efficient by creating internationally agreed design and manufacturing specifications and processes. They cover almost every part and process of a construction project, from standing soil to roofing.

Standards also provide a platform for new technologies and innovations. which helps the industry to respond to local and global challenges related to demographic evolution, natural disasters, climate change, etc.

Regulators

Regulators can be used as a technical basis for construction regulations and policies. Relying on harmonized test methods, processes and terminology that are continuously reviewed and improved.

consumers

Standards provide reassurance to consumers. The construction industry, by ensuring that buildings and related structures such as bridges are built to internationally agreed safety and quality standards. These things ensure that the buildings where people live, work and study. They are safe, comfortable and help as intended.

Structure design

The principles of structural design determine the basic requirements of structural design. With standards that specifically focus on terminology and symbols, loads and forces. This ensures that structures are built to last and can withstand external forces such as extreme weather events and natural disasters.

Develops standards for metal and aluminum structures. which specifies the requirements for the use of metal structures and aluminum alloys in the design, construction and installation of buildings and engineering works. Its scope includes materials, structural components and connections.

Construction materials and products

Relying on durable and quality materials is essential for the construction of safe and durable buildings. This section has standards related to raw materials used in construction such as concrete, cement, wood and glass. These include terminology standards, test methods and safety level assessments.

We also have a lot of standards when it comes to product manufacturing. Such as doors and windows, wooden panels, floor coverings, ceramic tiles, plastic pipes and fittings. These not only determine the correct dimensions and specifications to ensure that products are manufactured to the agreed quality level.

Instead, they define testing methods to assess product safety and resistance to things like crushing or chemicals so they don't spoil sooner.

Performance and energy sustainability

From insulation to energy saving products. Improving the energy performance of buildings can significantly contribute to climate-related goals. As a result, building regulations increasingly require energy-efficient designs. and actions are taken to help improve overall performance.

Department of thermal performance and energy use in the built environment. They have standards that provide guidelines and methods for calculating energy consumption in buildings such as heating, lighting, ventilation, etc. The design of the building environment has wide standards. which defines methods and processes for designing new buildings and retrofitting existing buildings. To create acceptable indoor environments and practical energy savings.

Fire safety

Fire causes destruction and costs people's lives. With the increase in housing density, fire protection and fire hazard detection have become more important.

Standards related to fire protection and fire extinguishing equipment. Includes items that include fire protection devices and equipment, including fire extinguishers and fire and smoke detectors.

Standards related to fire safety, by determining the behavior of building materials and structural structures, establish frameworks

for evaluating fire risks to life and property and reducing such risks, which, to ensure effective operation, specify the detection systems

and Fire alarms are used inside and around buildings, including testing and defining their performance.

Building information management

BIM building information models are commonly used digital representations of the physical and functional characteristics of any built object, including buildings, bridges, and roads. And it forms a reliable foundation for decision making.

They also help protect against losing valuable information between steps and processes. Information on construction works defines standards that define terms of reference and terminology used in BIMs, as well as requirements for the digital exchange of documents and data.

elevator and escalator

Increasing urbanization and dense populations mean that buildings around the world are getting taller. Therefore, efficient elevators and escalators are essential to cope with increased load and accessibility needs. And to evacuate skyscraper structures, they should be able to be used in case of accidents such as fire.

Elevators, escalators, and moving walkways have dozens of standards either published or under development. which covers everything from planning and installation to performance and energy safety.

Life planning, durability and lifecycle

It creates standards that provide guidance on how to plan for the useful life of buildings, including predicting the cost and frequency of maintenance and repairs throughout their life cycle. This series on useful life planning covers a wide range of topics in this field, such as audits and performance reviews, life cycle assessment and maintenance, and life cycle costs.

Who develops the standards?

Standards are developed by expert groups in technical committees. The committees consist of representatives of industry, non-governmental organizations, governments and other stakeholders.

which is provided by the standards organization. Each committee deals with a different topic. such as buildings and civil works or special building materials such as cement or wood. which is often associated with close cooperation with other international or intergovernmental organizations.

Ensuring that all structural components are strong enough to withstand the appropriate loads. And everything fits together as it should, the goal of a number of standards for construction. By establishing specific specifications and test methods, they help ensure that structures are designed and built to agreed levels of quality.

What is the valid certificate of product standard and construction material standard in Iran?

According to the two important articles 155 and 168 of the law of the fifth development program of the country, any type of construction must be done with standard materials and used by competent builders. According to statistics, currently more than 5 thousand producers of building materials, supplies and equipment are working in the country. which are the standard producers of Iran. First, there were 3,600 companies that notified manufacturers if their products had expired. It is better for standard manufacturers to think about the necessary arrangements for valid standard certification of their products. Today we are facing another phenomenon and manufacturers are entering our collection who have done a lot of research on their products. And they believe that for a more competitive and wider activity, they should take the standardization of their products seriously by the National Standards Organization of Iran.

The Iranian Standard Organization is one of the valid members of the World Standard Organization, which adheres to the international laws in two parts of the National Standard Organization.

International ISO issuance authorities

The International Organization for Standardization (ISO) is an international assembly of standard organizations of member countries, which operates as the center of this network in the city of

Geneva-Switzerland. For example, the technical committee (TC/176 regarding quality, the technical committee (TC/207 regarding the environment) and the technical committee (TC/34 regarding food industries) researched and compiled standards. This international authority, through certification issuing organizations (CB), monitors the performance of organizations and institutions applying for certification to comply with standard requirements and finally issue standard certification. In addition, IAF through certification organizations (AB) Monitors the performance of CB organizations.

Confidence in various matters and when using products and services is one of the inherent desires and expectations of humans. During different periods of creation and evolution of different products and services, organizations with the mission of creating confidence in various fields have been established and have been active. With the growth of the industry and extensive developments in different categories, the issuance of certification or specialized approvals has created confidence for the customers, beneficiaries and different products and services.

Conformity assessment certification for industrial products goes back to the middle of the 19th century, which has gradually established its position at the level of international trade. After issuing conformity certificates for products, the subject of issuing certificates for process and system was also taken into consideration.

With the emergence of different professional, commercial and international requirements, various standards for the functions and criteria of processes as well as organizing management systems with different approaches were formulated. This caused the expansion of the culture of evaluation/audit of processes and systems and certification for them.

Organizations that issue certificates are independent legal organizations that have been established in different parts of the world and define different operational areas according to economic/commercial expansions and operate internationally by

Reference Book Of International Building Standards —Chapter Three

having branches and affiliated organizations. do These collections operate under the title (Certification BodyCB). It is necessary to

explain that according to the nature of some standards such as ISO 15189, ISO 17020, ISO 17021, ISO/IEC 17025, etc., accreditation bodies or (Accreditation Bodies AB) provide accreditation certificates.

ISO

The International Standard Organization is an international standard development organization that is made up of representatives of the national standard organizations of the member countries. Membership requirements are listed in Article 3 of the ISO Constitution.

ISO was founded on February 23, 1947 and (as of November 2022) has published more than 24,500 international standards covering almost all aspects of technology and production. It has 809 technical committees and subcommittees to oversee the development of standards. It develops and publishes standardization in all technical and non-technical fields except electrical and electronic engineering, which is administered by the IEC. It is headquartered in Geneva, Switzerland, and operates in 167 countries as of 2022. Three The official languages of ISO are English, French and Russian.

Structure and organization

ISO is a voluntary organization whose members are official standards authorities, each representing a country. Members meet annually in a general assembly to discuss ISO's strategic goals. The organization is coordinated by the central secretariat based in Geneva.

A rotating council of 20 members provides guidance and governance, including setting the annual budget of the Central Secretariat.

The Technical Board is responsible for more than 250 technical committees that develop ISO standards.

International standards and other publications

International standards are the main products of ISO. It also publishes technical reports, technical specifications, publicly available specifications, technical amendments, and manuals.

international standards

These use the format ISO[/IEC] [/ASTM] [IS] nnnnn[-p]:[yyyy] title, where nnnnn is a standard number, p is an optional part number, yyyy is the year of publication, and title Describes the subject. If the standard results from the work of ISO/IEC JTC 1 (ISO/IEC Joint Technical Committee), IEC is included for the International Electrotechnical Commission. ASTM (American Society for Testing and Materials) for standards developed in collaboration with ASTM International. yyyy and IS are not used for an incomplete or unpublished standard, and under certain circumstances the title of a published work may be omitted.

Technical reports

These are issued when a technical committee or sub-committee has collected data of a different type than that normally published as an International Standard, such as references and explanations. The naming conventions for these are the same as the standards, except that TR is added instead of IS in the report name.

For example:

ISO/IEC TR 17799:2000 Code of Practice for Information Security Management

ISO/TR 19033:2000 Technical product documentation - Metadata for construction documentation.

Technical specifications available to the public

Technical specifications may be submitted when "the subject matter is still under development or for any other reason that agreement to publish an international standard is possible in the future but not immediately". A publicly available specification is usually "an

intermediate specification published prior to the development of a full international standard, or in IEC it may be a 'dual logo'

publication published in collaboration with an external organization". By convention, both types of specifications are named in a similar way to the organization's technical reports.

For example:

- ISO/TS 16952-1:2006 Product technical documentation - Reference designation system - Part 1: General application rules
- ISO/PAS 11154:2006 Road vehicles – Roof carriers

Technical corrections

ISO also sometimes issues a "technical correction", where "correction" is the plural of corrigendum. These are modifications made to existing standards due to minor technical defects, usability improvements, or extensions of limited use. They are usually issued with the expectation that the affected standard will be updated or withdrawn at the next scheduled review.

ISO guide

These are meta-standards that cover "issues related to international standardization". They are named using the format "ISO/[IEC] Guide N:yyyy:Title".

For example:

- ISO/IEC Guide 2:2004 Standardization and related activities – General vocabulary
- ISO/IEC Guide 65:1996 General requirements for organizations performing product certification (since revised and reissued as ISO/IEC 17065:2012 Conformity assessment - Requirements for organizations performing certification of products, processes and services.

Document copyright

ISO documents have strict copyright restrictions and ISO fees for most versions. As of 2020, the typical cost of an ISO standard cofoundation is about US\$120 or more (and electronic versions

usually have a single-user license, so they cannot be shared among groups of people. Some ISO standards and its official representative

In the United States (and through the US National Committee, the International Electrotechnical Commission are available free of charge.

Standardization process

A standard published by ISO/IEC is the last step in a long process that usually begins with the initiation of new work in a committee. Some of the abbreviations used to mark a standard with its status are:

- PWI - Preliminary work item
- NP or NWIP - New Pre-Entity / New Work Pre-Entity / eg ISO/IEC NP 23007
- AWI - new approved work item/eg, ISO/IEC AWI 15444-14
- WD - working draft / eg, ISO/IEC WD 27032
- CD – Committee Draft / eg ISO/IEC CD 23000-5
- FCD - Final Committee Draft / eg ISO/IEC FCD 23000-12
- DIS - Draft International Standard / eg, ISO/IEC DIS 14297
- FDIS - Final Draft International Standard / eg, ISO/IEC FDIS 27003
- PRF - proof of a new international standard / for example, ISO/IEC PRF 18018
- IS - International standard / for example, ISO/IEC 13818-1:2007

Abbreviations used for amendments are:

- NP Amd – new precursor amendment/ eg ISO/IEC 15444-2:2004/NP Amd 3
- AWI Amd – Approved new work item amendment / eg ISO/IEC 14492:2001/AWI Amd 4

Reference Book Of International Building Standards —Chapter Three

- WD Amd – working draft amendment / eg ISO 11092:1993/WD Amd 1

- CD Amd / PDAmD – Committee Draft Amendment / Institutional Draft Amendment / eg ISO/IEC 13818-1:2007/CD Amd 6
- FPDAmD / DAM (DAmd – final pre-institutional draft amendment / draft amendment / eg ISO/IEC 14496-14:2003/FPDAmd 1
- FDAM FDAmd – Final Draft Amendment/ eg ISO/IEC 13818-1:2007/FDAmd 4
- PRF Amd - / for example, ISO 12639:2004/PRF Amd 1
- Amd – amendment / for example, ISO/IEC 13818-1:2007/Amd 1:2007

Other abbreviations include:

- TR - Technical Report / eg, ISO/IEC TR 19791:2006
- DTR - Draft Technical Report / eg, ISO/IEC DTR 19791
- TS - Technical specifications / eg, ISO/TS 16949:2009
- DTS - Draft Technical Specifications / eg, ISO/DTS 11602-1
- PAS - public profile available
- TTA - Assessment of Technology Trends/ eg, ISO/TTA 1:1994
- IWA - International Workshop Agreements / eg, IWA 1:2005
- Cor - technical correction/ eg ISO/IEC 13818-1:2007/Cor 1:2008
- Guidance – Guidance for technical committees to prepare standards

International standards are developed by ISO TC technical committees and SC subcommittees through a six-step process:

- Stage 1: Pre-institution stage
- Stage 2: Preliminary stage

- Stage 3: Committee stage

- Step 4: Inquiry step
- Step 5: Confirmation step
- Stage 6: The stage of publication of international workshop contracts

IWAs international workshop agreements follow a slightly different process outside the usual committee system, but under ISO supervision, allowing "key industry players to renegotiate in a workshop environment" to shape the IWA standard.

Products with ISO name

Sometimes, the fact that many standards created by ISO are ubiquitous has led to the common use of "ISO" to describe a product that conforms to a standard. Some examples of these are:

- Disc images end with the ISO file extension to indicate that they use the standard ISO 9660 file system as opposed to another file system - hence disc images are commonly referred to as ISO.
- The sensitivity of photographic film to light, its "film speed" is described by ISO 6, ISO 2240 and ISO 5800. Hence, film speed is often identified by its ISO number.
- As originally defined in ISO 518, the flash hot shoe found on cameras is often called the ISO "shoe".
- ISO 11783, which is marketed under the name ISOBUS.
- ISO 13216, which is marketed under the name ISOFIX.

National Green Building Standard

The National Green Building Standard (NGBS) is an ANSI-approved green building certification program that focuses specifically on single-family and multi-family residential buildings, renovation projects, and land development.

Reference Book Of International Building Standards —Chapter Three

In partnership with ASHRAE, the International Code Council (ICC) and the National Association of Home Builders NAHB, the NGBS was created to provide a uniform national platform for the

recognition and advancement of green residential construction and development.

To date, more than 100,000 residential units are green certified with the National Green Building Standard.

Rating system

NGBS is a points-based system in which single-family or multi-family building(s) can achieve certification depending on sustainable and green practices in design and construction and planning for its operation and maintenance. Projects can qualify for four certification levels (Bronze, Silver, Gold or Emerald) by earning the required number of points for each level.

ANSI approved consensus

The 2015 edition of the NGBS is the third iteration of the NGBS, building on the previous editions of 2012 and 2008. All versions of the standard were developed by industry consensus committees and non-profit individuals in partnership with the ICC and NAHB. The 2015 edition of NGBS introduced a new partner in the development process, ASHRAE. The staff of these three organizations did not serve as members of the consensus committee and only assisted in facilitating the meetings.

NGBS is the only residential-specific green building rating system that has gone through a full consensus process and received approval from the American National Standards Institute (ANSI). ANSI certification is critical because it serves as a third-party verification of balance, representativeness, openness, consensus, and due process in the development process. The consensus committee that developed the 2015 edition of the standard consisted of 42 individuals representing government agencies, municipalities, homebuilding industry stakeholders, and nonprofit organizations, including but not limited to:

- National Multifamily Housing Council
- National Institute of Standards and Technology

- Northeast Energy Efficiency Partnerships

- Texas A&M University
- US Department of Energy (DOE)
- US Department of Housing and Urban Development (HUD)
- American Institute of Architects (AIA)
- City of Des Moines

Grouping

Points are earned when a project meets multiple green building practices set forth in the standard. These methods are divided into six general categories:

- Part design, preparation and development
- Resource efficiency
- energy efficiency
- Water efficiency
- Indoor environmental quality
- Operation, maintenance and training of the building owner

Certification levels

Projects can qualify for four levels of certification by obtaining the total points required for each level:

- Bronze: 231 points
- Silver: 334 points
- Gold: 489 points
- Emerald: 611 points

NGBS is designed so that a project team must have a multifaceted approach to green building. This requires that a project achieve a minimum number of points in each green practice category to be

approved, as well as a minimum number of additional points from any category it chooses. This prevents project teams from getting all

their points by focusing on a handful of categories and ignoring others due to difficulty.

The highest score of a building depends on the lowest threshold that each of the six categories has. For example, if a project passes the threshold for Emerald in one category by one point, it will still only achieve Gold certification even if it achieves the number of points required for Emerald certification in all other categories.

In addition, for residential units greater than 4,000 square feet, the total number of points required to obtain certification levels increases by one point for each additional 100 square feet. This makes it more challenging for larger houses to get the same certification as smaller houses to take into account the larger environmental impacts of larger living spaces.

Types of eligible projects

Residential buildings

NGBS is specifically designed for residential construction, development and renovation. The types of eligible buildings that can receive certification through the standard are:

- Single family homes
- Low-rise multi-family
- Several high-ranking families
- Residential parts of mixed-use buildings
- Cheap housing
- Renovation of existing houses

land development

Within the NGBS, and separate from individual buildings and renovations, a development can be certified for design and preparation in accordance with green practices. Similar to buildings,

line development projects can qualify for four different rating levels:

- 1-star: 95 points
- 2-star: 122 points
- 3-star: 149 points
- 4-star: 175 points

For land development projects, points are not divided between individual categories, but rather a collection of different practices such as stormwater management, natural resource protection, and planning.

Certification process

Compliance with NGBS is verified through construction documents, drawings, specifications, inspection reports and other data that demonstrate compliance with the points to be followed. All NGBS project teams must have an NGBS Green Verifier who serves as an independent and internal representative of the NGBS Green certification system. Approvers work with project teams to perform rough and final construction inspections as described below. To achieve certification, these inspection reports, along with relevant information on the practices followed, are made available to home innovation laboratories for technical review and approval.

Each project is subject to two mandatory independent third-party verification inspections. The accredited verifier is responsible for the visual inspection of each green building in the building. The verifier must conduct a general inspection to check for wall voids in each apartment before installing drywall, and a final inspection of each apartment after the project is completed. The required verification brings a high level of accuracy, continuity and quality assurance to the system and projects being certified.

Determinations

Green verifier

Home Innovation Labs qualifies, trains and accredits building professionals to provide independent verification services for builders participating in our NGBS Green Certification program.

Certifiers must first demonstrate that they have experience in residential construction and green building before they are eligible to participate in the certifier's training course.

Most verifiers are also HERS raters and/or LEED Accredited Professionals. Potential approvers must complete a thorough training on how to approve each NGBS practice. After completing the training course, certifiers must pass a written exam and renew their credential annually before receiving accreditation.

Home Innovation Labs regularly reviews the verifiers and approvals they perform as part of our internal quality assurance program. NGBS Green Verifier accreditation is earned by individuals and does not extend to the entire company.

Green professional certificate

The Certified Green Professional CGP designation is offered by NAHB and recognizes builders, remodelers and other industry professionals who incorporate green and sustainable building principles into homes. The required courses provide a background in green building methods as well as tools to reach consumers, from the organization responsible for providing market-based green building solutions [buzzword] to the home building industry.

CGP courses are aligned with the ICC/ASHRAE National Green Building Standard 2015-700, which includes chapters on energy, water and resource efficiency, indoor environmental quality, land and site development, and homeowner education, and is the core curriculum for needed.

CGP classes

There are nearly 3,000 active CGPs in the United States working in all aspects of the high-performance home building and remodeling industry.

Green certified products

The NGBS Green Certified Product program bridges the gap between manufacturers who produce NGBS certified products and builders/designers who want to use them in homes.

To qualify for the NGBS Green Certified Products Program, manufacturers must provide Home Innovation Labs with appropriate third-party evidence that their products meet the criteria for identification in buildings seeking NGBS Green Home Certification. NGBS Green Certified products receive a certificate that identifies the specific NGBS sector(s) where the rating is available for the product. This information facilitates designers' selection of products for use in green homes and verification of those points by Home Innovation's approved green building verifiers.

Notable buildings of NGBS

Salmon Creek Zero Home:

The Salmon Creek Net Zero Home is a single family home built in Vancouver, Washington. It earned NGBS certification at the Emerald level, the highest level of certification available.

This home was built by Urban NW Homes in a neighborhood with only Emerald Level homes, the first of its kind on the West Coast. The notable features of this house that helped to obtain the certificate are:

- Construction of stepped studs to reduce material consumption
- Triple-glazed windows to increase energy efficiency and reduce heat loss
- Cork entrance flooring, a highly renewable resource
- Rebuilt internal doors, to reduce resource consumption
- A washing machine that irrigates the yard and reduces water consumption
- lifebreath air purifier, for excellent indoor air quality

Renovation of Norcross:

The Norcross rebuilding Project is a single family home renovation located in Dallas, Texas. It obtained NGBS certification at the bronze level.

According to the owners, as their family grew, they needed more space.

Ferrier Builders completed the addition to their existing home with sustainable, high-performance features, including:

- New windows and doors with high efficiency
- Spray foam insulation on the walls and ceiling
- ENERGY STAR kitchen and laundry appliances
- Solar tubes to help with natural daylight

Ruxton:

This is a mixed-income multifamily rebuild project located in Denton, Texas. It earned NGBS certification at the Emerald level, the highest level of certification available.

This low-rise urban multi-family apartment complex consists of 16 buildings including 126 residential units. The project was an interior renovation of a 1970s building, and green building practices helped save 63 percent of water compared to the original building.

Smart building standards

A smart building is a building that has a dynamic and cost-effective environment by integrating four main elements, namely systems, structure, services, management and the relationship between them. In other words, a smart building is a building in which all its internal components interact with each other through creating an integrated and logical system compatible with the environment. On the other hand, energy management (EMS) can lead to a 10-30% reduction in cost and price. The global market of smart homes and buildings is divided into four groups: product market, end user market, technology market, and application market.

Smart building equipment

Smart homes are generally divided into two parts: the construction of ready and under construction smart buildings and the construction of smart buildings.

Considering that changes in built buildings are more difficult, therefore, wireless smart system is used more.

Smart building application

This application, which is provided to the users of smart homes, can control and monitor all the systems desired by the user either inside the house or outside the house through the mobile phone. This software is provided for all operating system versions and can be installed on all types of Android and IOS mobile phones.

EMS systems and various applications

EMS are control systems that prevent energy loss by adjusting the hourly and periodic operation of equipment. That is, it adjusts the time and range of turning on and off devices based on predetermined data based on a unique system and with the help of control clocks.

Lower cost of living

In the design of the system, according to the available options, the current costs must be evaluated first. In this case, attention should be paid to the efficiency of energy consumption and its saving. The location and orientation of the building, temperature stability, the effect of wind, weather, lighting and natural ventilation are very important. In buildings with high energy consumption, an analysis should be done on the periodic costs of life and based on that, principles should be designed that actually have a direct impact on the costs.

Building maintenance

One of the applications of sensors used in smart buildings can be the interaction of these sensors with building information modeling (or simultaneous use with a laser scanning system) to check the current state of the building and make decisions about maintenance operations. And plan for preventive maintenance. It is named in the building. Smart building also increases their safety level.

Smart building equipment

Although there are many smart building system devices, some of the most important smart home equipment are:

Central processor: The processor can be introduced as the beating heart of smart home equipment. Because the central processor is responsible for communication between all components. The central processor is divided into different types according to the information processing power.

Sensor: The function of sensors is to collect information from the environment and send it to the central processor. Motion sensors, temperature, building and parking door opening sensors, door and window magnet sensors, etc. are among the most widely used sensors in the manufacture of smart equipment.

Wall panel: The panel is actually a screen to control and access all the electrical equipment of the smart building. Panels are available in different sizes in the market.

Relay: One of the most widely used smart home equipment is the relay. The role of the relay is to turn on and off the electric current. Using smart relays, you can control lighting, heating and cooling systems, electric valves and building equipment.

Among other smart building equipment, we can mention the lighting system, sound system, smart parking, smart temperature control, etc.

Due to the fact that the use of smart facilities has gained many fans, companies producing smart home equipment have started to manufacture and produce highly functional equipment in different designs to satisfy their customers.

BMS

BMS standard is intelligent building management.

This word stands for Building Management System, which means intelligent building management. In fact, BMS refers to a set of

hardware and software that are installed for the purpose of integrated monitoring of vital parts in the building.

The task of this equipment is actually:

Continuous monitoring of different parts of the building

Applying orders to these sections

in such a way that the performance of different parts of the building is balanced with each other and in optimal conditions.

Also, one of the goals is to reduce unwanted consumption and allocate energy resources only to spaces during operation. BMS including all electrical and mechanical equipment and. . . It is a building.

It is usually easier to get BMS standards for buildings that have proper engineering than for buildings that do not follow foundation engineering standards.

Companies that are in the field of building construction receive this standard for their organization and implement it in their executive projects.

As mentioned before, important ISO standards in civil and construction fields include:

ISO 9001, ISO 14001, ISO 45001, HSE-MS, IMS, ISO 21502 and ISO 21500 and... Are.

Objectives of implementing BMS in organizations

Creating a pleasant and peaceful environment for people in the building

Providing a suitable control system

The possibility of monitoring all parts of the building

Receive statistical reports of all equipment and their performance

Significant reduction in energy consumption costs

Increasing the useful life of building equipment and...

The mentioned items are some of the goals of the BMS standard for intelligent building management.

Issuance of BMS certification

Hina Sert company provides immediate issuance services of all kinds of international standards from reliable and appropriate authorities.

For the issuance of BMS certificate, some issuing authorities provide services in the form of compliance and self-declaration.

Knx standard in building smartness

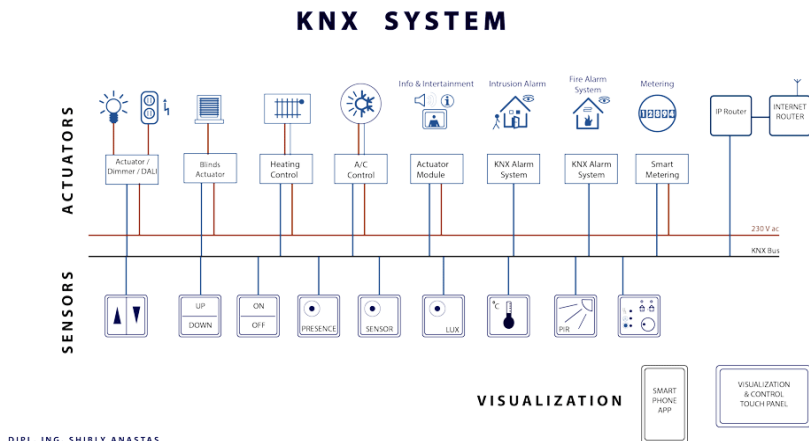

Introduction of BUS systems

BUS intelligent systems have created more efficient, safer, more flexible and economical buildings. It makes it more comfortable. KNX has taken a large share of the market of building automation systems, BMS building intelligence.

Significant measures have been taken to make the BMS building smart

Therefore, electrical installations in a smart building have significant work to do. Sensors and actuators in the intelligent network have been a standard feature of car engines for a long time. On the other hand, the buildings are left behind from this development. Especially due to the long service life of electrical installations, a change of mentality is necessary. New buildings

today must adapt to countless changes over the next few decades. Now more than ever, buildings must be flexible and able to accept

networked smart building services. From a technical point of view, all these building smart possibilities are already quite possible.

More networks in building smartness

The main thing that makes a building "smart building" is to equip it with network sensors and actuators. There are several different ways to make the BMS building smart:

Conventional methods of building smartness

In BMS building smartness, the clear and direct solution is to obtain a star topology, that is, an arrangement in which the output socket of each circuit, ceiling or wall socket and optical switch is connected to a central distribution board by its ideal five-core semi-transparent cable. It is connected in which there is logic. Control relationships are established by contactors, switch relays and a PLC programmable logic controller.

This works well in reasonable and small buildings. However, the size of the house only needs to be increased by a relatively small amount before the amount of wiring work and the size of the switchboards required becomes excessive. In a star topology, adding or expanding the smart system is very time-consuming in terms of installation and programming.

History of KNX in BMS building smart system

The KNX building automation system was originally known as EIB European Bus Installation and was developed and marketed by the EIB Association (EIBA. In 1999, EIBA, Batibus Club International, BCI) France and the European Building Automation Systems Association EHSA, Netherlands. merged together,

The KNX Building Smart Building Standard Association BMS was founded in 1999 with headquarters in Brussels by the merger of three previous European associations promoting smart homes and buildings. These associations are:

- BCI Association (France promotes the Batibus system)

- EIB Association (Belgium promotes the EIB system)

- EHS Association (Holland European home systems that promotes the EHS system.)

The above associations adopted the name KNX and the KNX Association was established. The technology used in modern KNX devices is compatible with the old EIB system, so all KNX devices with the EIB logo are compatible with each other.

A brief description of the KNX standard

The KNX Association, as a BMS building intelligentization standard, pursues the following goals:

- Defining a truly open KNX standard for the smart home and smart building
- Establishing the KNX brand as a sign of quality work and having multiple vendors
- Establishing KNX as a European and global standard for building smartness

As long as it is necessary, the KNX community also provides support for Batibus, EIB and EHS legacy systems, including certification according to these previous standards. Since EIB is backward compatible with KNX, most devices can be labeled with KNX as well as with the EIB logo.

The KNX community consisted of 9 members at the time of its founding: meanwhile this number has grown to more than 300 members. including companies that have not previously been members of any of the previous associations. These companies represent more than 80% of the European market for appliances and white goods.

About merged forums

Batibus Club became the national KNX group of France.

The KNX Association has undertaken the development and sale of KNX software

Packages from EIBA Brussels. This includes, among others, ETS (engineering tool software);

EHSa was integrated into KNX structures.

At the end of 2003, the KNX Building Smart Standard (BMS by CENELEC) was approved by the European Committee for Electrotechnical Standardization as the European standard for smart home and smart building. Electronic systems as part of the EN 50090 series. The KNX standard was also approved by CEN (EN 13321-1 for media and protocol and EN 13321-2 for KNXnet/IP.

At the end of 2006, KNX was also approved as a global building smart standard ISO / IEC 14543-3. In 2007, the Chinese translation of the international standard achieved GB/Z status as GB/Z 20965. KNX is also certified to ANSI/ASHRAE135 in the US.

What is the KNX system in smart building?

KNX system is a BUS system for BMS building control and intelligentization. This means that all devices of a KNX system use the same transmission method and are able to exchange information through a common BUS network, which results in the following:

- Access to the BUS network must be clearly set (BUS access method)
- Most of the data transmitted is not useful information. (eg turn on/off the lights except address information) I mean, where does the data come from? Where are they going?

Another important feature of the BUS KNX system in the smart building is its decentralized structure: there is no need for a central control unit, because the "intelligence" of the system is distributed among all its devices. Centralized units, although it is possible to realize very specialized software. Each device has its own microprocessor.

One of the main advantages of the decentralized structure of KNX as a BMS building intelligence system is that if one device fails, the

other devices will continue to function. Only functional programs dependent on the broken device are disrupted.

In general, in a KNX home automation system, devices fall into three categories:

- 1 - Smart system devices (power supply, programming interface, etc.)
- 2 - Smart system sensors
- 3 - Stimulators of the intelligentization system

Sensors are devices that detect events in the building (for example, someone pressing a button, someone moving, temperature rising or falling from a set value, etc.). It converts these into telegrams (data packets) and sends them along the BUS network. Devices that receive telegrams and convert the commands embedded in them into actionable actions are known as triggers. Sensors issue commands, while actuators receive them.

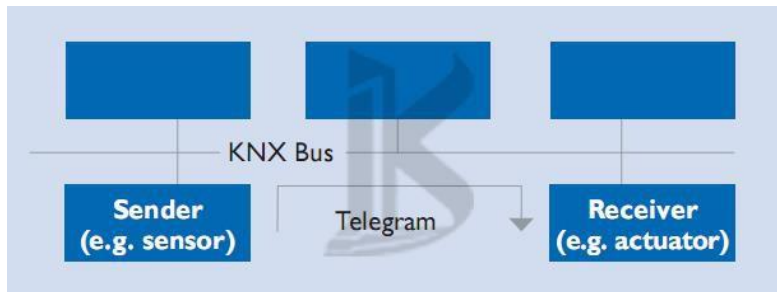

The general principle of sensor/actuator in smart building (BMS)

How extensive can the KNX system be in a smart building?

KNX BUS systems (intelligent building system) can be modified and added exactly as needed. The smallest KNX application of the home smart home standard may be a system that connects two BUS devices: a sensor and an actuator. This foundation system will later It can be upgraded with the number of devices required to perform the desired control tasks.

Theoretically, a KNX system can consist of more than 50,000 devices. When expanding the standard KNX system that can be used in a smart home, it is necessary to observe a certain topology.

What communication media is available in KNX building smartness?

Various communication media (transmission methods) can be used to exchange data between devices in the KNX system:

- KNXT wisted Pair KNX TP - communication through twisted pair data cable (BUS cable)
- KNX PL KNX Powerline – uses the existing 230V mains
- KNX RF KNX Radio Frequency – communication through radio signal
- KNX IP – communication through the Internet

BUS systems should be very easy to install, add and generally work with. The wide selection of KNX communication media means that KNX (BMS system) can be used in any situation. For example, when moving BUS devices even in the most winding buildings.

Green building and energy management

Green building, also known as green construction or sustainable building, refers to the structure and application of processes that are environmentally responsible and resource efficient throughout the life cycle of a building: from planning to design, construction, operation. Removal, maintenance, renovation, and demolition of this requires close cooperation of contractors, architects, engineers, and the employer in all phases of the project. Green building practice extends and complements classical building design concerns of economy, utility, durability, and comfort. The green building also helps to save resources as much as possible, such as saving energy, saving land, saving water, saving materials, etc. in the entire life cycle of the building, protecting the environment and reducing pollution, providing health And it refers to the comfort of the people. and optimal use of space and harmony with the nature of buildings that live harmoniously. Green building technology focuses on low consumption, high efficiency, economy, environmental protection, integration and optimization.

Leadership in Energy and Environmental Design (LEED) is a set of rating systems for the design, construction, operation and maintenance of green buildings developed by the US Green Building Council. Other certification systems that confirm the sustainability of buildings are the British BREEAM, the Building Research Institute's environmental assessment method for large-scale buildings and developments, or the DGNB (Deutsche Gesellschaft für Nachhaltiges) Bauen eV system, which assesses the sustainability performance of buildings indoors. Specifies. and regions Currently, the World Green Building Council is conducting research on the effects of green buildings on the health and productivity of users and is working with the World Bank to promote green buildings in emerging markets through the Market Transformation Program and the EDGE Certification of Excellence in Design for Efficiency. Cooperates more. There are also other tools such as the Green Star in Australia, the Global Sustainability Assessment System (GSAS) in the Middle East and the GBI Green Building Index, which is mainly used in Malaysia.

Natural building is a similar concept, usually on a smaller scale and focusing on the use of locally available natural materials. Other related topics include sustainable design and green architecture. Sustainability may be defined as meeting the needs of the present generation without compromising the ability of future generations to meet their own needs. Although some green building programs do not address retrofitting existing homes, others do, particularly through public initiatives for energy-efficient retrofits. Green building principles can easily be applied to retrofitting as well as new construction.

A 2009 report by the US Public Utilities Administration identified 12 sustainably designed buildings that cost less to operate and have excellent energy performance. In addition, residents were generally more satisfied with the building than residents of typical commercial buildings. These are environmentally friendly buildings.

Reducing environmental impacts



One Central Park Hanging Gardens, Sydney

Buildings constitute a large part of the consumption of energy, electricity, water and materials. As of 2020, they account for 37% of global energy consumption and energy-related CO₂ emissions, which the United Nations estimates account for 33% of total emissions worldwide. Including the manufacture of construction materials, global CO₂ emissions were 39%. If new technologies in construction are not adopted during this time of rapid growth, greenhouse gas emissions could double by 2050, according to the United Nations Environment Program.

The goal of green building measures is to reduce the environmental impact of buildings because the building sector has the greatest potential for significant reductions in greenhouse gas emissions at little or no cost. The general guidelines can be summarized as follows: Each building should be as small as possible. Avoid contributing to littering, even if the most energy-efficient and environmentally friendly methods are used in design and construction. The principles of bioclimatic design are able to reduce energy consumption and consequently carbon emissions. Bioclimatic design is a method of designing infrastructure within the context of its respective environment while using the surrounding environment to its advantage whenever possible. This could be as simple as creating a different shape for the building envelope or facing the building to the south to maximize sun exposure for energy or lighting purposes. Due

to the limitations of planned urban construction, bioclimatic principles may be used on a

smaller scale, yet it is still an effective passive method to reduce environmental impacts.

Buildings take up a lot of land. According to the National Resource Inventory, approximately 107 million acres (430,000 km²) of land in the United States have been developed. The International Energy Agency published a publication that estimated that existing buildings account for more than 40 percent of the world's total primary energy consumption and 24 percent of global carbon dioxide emissions.

According to the State of the World report from 2016, buildings consume more than 30% of the total energy produced. The report states that "on a below 2°C trajectory, effective action to improve building energy efficiency could limit the final building energy demand above current levels, meaning that the average global building stock energy intensity would exceed decreases from 80 percent. until 2050".



Blu Homes mkSolaire, a green building designed by Michelle Kaufman.



Shanghai Tower, the tallest and largest LEED Platinum certified building in the world since 2015

Life cycle assessment

Life cycle assessment (LCA) can help avoid a limited perspective of environmental, social and economic concerns by assessing the full range of impacts associated with all stages from cradle to grave of a process: from the extraction of raw materials through materials processing, manufacturing, distribution, use, maintenance, and disposal or recycling. Impacts considered include (among others) embodied energy, global warming potential, resource use, air pollution, water pollution, and waste.

Although LCA is widely recognized as the best way to assess the environmental impact of buildings, ISO 14040 provides a recognized LCA methodology, despite the fact that embodied energy is still an established requirement for rating systems and codes. Green buildings are not, and other life cycle impacts are critical to environmentally responsible building design.

In North America, LCA is partially rewarded in the Green Globes rating system and part of the new US National Standard based on:

Green Globes is ANSI/GBI 2010-01: Green Building Protocol for Commercial Buildings. LCA is also included as a pilot credit in the LEED system, although a decision has not been made on whether it will be fully included in the next major revision. The State of California also included LCA as a voluntary measure in the 2010 Draft Green Building Standards Code.

Although LCA is often considered too complex and time-consuming for regular use by design professionals, research organizations such as the BRE in the UK and the Athena Sustainable Materials Institute in North America are working to make it more accessible.

In the UK, the BRE Green Guide to Specifications provides a rating of 1,500 building materials based on LCA.

Efficiency of site and structure design

The foundation of every construction project is rooted in the conceptual and design stages. The conceptual phase is, in fact, one of the main phases in the project life cycle, as it has the greatest impact on cost and performance. In designing environmentally optimal buildings, the goal is to minimize the total environmental impact associated with all phases of the building project's life cycle.



Outdoor Light Racks - Green Office Building, Denver, Colorado

However, building as a process is not as simple as an industrial process, and it varies from building to building and is never

repeated in the same way. Moreover, buildings are much more complex products consisting of numerous materials and

components, each of which constitutes different design variables that are decided during the design phase. A change of any design variable may affect the environment during all phases of the relevant life cycle of the building.



An ecological house in the village of Findhorn with a grass roof and solar panels

energy efficiency

Green buildings often include measures to reduce energy consumption—both the embodied energy required to extract, process, transport, and install building materials, and the operational energy to provide services such as heating and electricity for equipment.

As high-performance buildings use less operational energy, embodied energy has become much more important—and may account for up to 30% of total life-cycle energy use. Studies such as the US LCI Database Project show that buildings constructed primarily of wood have lower embodied energy than buildings constructed primarily of brick, concrete, or steel.

To reduce operational energy consumption, designers use details that reduce air leakage through the building envelope of barriers between the conditioned and unconditioned space. They also feature high-performance windows and additional insulation in walls, ceilings and floors. Another strategy, passive solar building design,

is often implemented in low energy homes. Designers orient windows and walls and place canopies, porches, and trees to shade

windows and roofs during the summer while maximizing solar gain in the winter. Additionally, effective daylight window placement can provide more natural light and reduce the need for electrical lighting during the day. Solar water heating further reduces energy costs.

On-site renewable energy production through solar energy, wind power, hydroelectricity or biomass can significantly reduce the environmental impact of the building. Power generation is generally the most expensive feature to add to a building.

Energy efficiency for green buildings can be evaluated by two numerical or non-numerical methods. These include the use of simulation modeling, analytical or statistical tools.

Water efficiency

Reducing water consumption and maintaining water quality are key goals in sustainable construction. One of the major water consumption issues is that in many areas, the demand on the supplying aquifer exceeds its ability to recharge. To the extent possible, facilities should increase their reliance on water that is collected, used, treated and reused on site. Conserving water over the life of a building may be done by designing for dual plumbing that recycles water in toilet flushing or by using water to wash cars. Water waste may be minimized by using water conservation devices such as ultra-low-flush toilets and low-flow showerheads. The prices help eliminate the use of toilet paper, reduce sewer traffic, and increase the likelihood of on-site water reuse. Point-of-use water treatment and heating improves water quality and energy efficiency while reducing the amount of circulating water. Using non-wastewater and gray water for on-site use such as on-site irrigation minimizes demand on the local aquifer.

Material performance

Building materials commonly considered "green" include: wood that is certified by a third-party standard, rapidly renewable plant materials (such as bamboo and straw, dimension stone, recycled

stone, concrete, recycled metal); See: Copper sustainability and recyclability and other non-toxic, reusable, renewable or recyclable

products. Materials with lower embodied energy can be used instead of conventional building materials with high levels of energy consumption and harmful carbon emissions. A high-performance self-healing version is available for concrete, however, less polluting waste-efficient options entertain ideas of recycling and supplement collection. Replacing traditional concrete mixes with slag, manufacturing waste and aggregates, insulation also sees multiple angles for replacement. Conventional fiberglass competes with other environmentally friendly, low-energy insulations with similar or higher R-values per inch of thickness at a competitive price. Fleece, cellulose, and ThermaCork are more efficient, however, their use may be limited by shipping or installation costs.

Improving the quality of the indoor environment

The IEQ indoor environment quality category in the LEED standards, one of the five environmental categories, was created to provide occupant comfort, well-being and productivity. The LEED IEQ category addresses design and construction guidelines, specifically: indoor air quality (IAQ), thermal quality, and lighting quality.

Indoor air quality aims to reduce volatile organic compounds (VOCs) and other air impurities such as microbial pollutants. Buildings rely on a well-designed passive natural or mechanical ventilation system to provide adequate ventilation of cleaner air from outdoors or recirculated treated air as well as separate kitchen, laundry, etc. operations from other areas. During the design and construction process, choosing building materials and interior finishing products with zero or low VOC emissions improves IAQ. Most building materials and maintenance cleaning products emit gases, some of which are toxic, such as many VOCs, including formaldehyde. These gases can negatively affect the health, comfort and productivity of passengers. Avoiding these products increases the IEQ of the building.

Optimizing operation and maintenance

No matter how sustainable a building is in its design and construction, it can only be sustainable if it is operated responsibly and maintained properly. Ensuring that operations and maintenance

(O&M) personnel are part of the project planning and development process helps maintain the green criteria designed at the start of the project. Every aspect of green building is integrated into the O&M phase of a building's life. Add New green technologies are also the responsibility of O&M staff. Although the goal of waste reduction may be applied in the design, construction, and demolition phases of the building life cycle, it is in the O&M phase that green actions such as recycling and improving air quality are implemented. The goal of O&M staff It should establish best practices in energy efficiency, resource conservation, environmentally sensitive products, and other sustainable practices. Education of building operators and occupants is key to effectively implementing sustainable strategies in O&M services.

waste reduction

Green architecture also seeks to reduce the waste of energy, water and materials used in construction. For example, in California nearly 60 percent of the state's waste comes from commercial buildings. During the construction phase, a goal should be to reduce the amount of material going to landfills. Well-designed buildings also help reduce the amount of waste generated by residents by providing solutions such as compost bins to reduce waste to landfills.

To reduce the amount of wood going to landfills, the Neutral Alliance (a coalition of government, non-governmental organizations and the forest industry) created the website dontwastewood.com. This site contains a variety of resources for regulators, municipalities, developers, contractors, owner/ Operators and individuals/homeowners seeking information on wood recycling.

When buildings reach the end of their useful life, they are usually demolished and sent to landfills. Deconstruction is a method of taking what is usually considered "waste" and turning it back into useful building materials. Extending the useful life of a structure also reduces waste - building materials such as wood, which are light and easy to work with, make renovation easier.

There are several options to reduce the impact on wells or water treatment plants. "Grey water", the effluent from sources such as dishwashers or washing machines, can be used for subsurface irrigation or, if treated, for non-potable purposes, for example, for flushing toilets and washing cars. Rainwater collectors are used for similar purposes.

Reducing the impact on the power grid

Power grids are built based on the demand factor (another name is the load factor. The demand factor is measured in units of watts, W. It shows how fast electrical energy is consumed. Household electricity is often charged with electrical energy. (kWh). Green buildings or sustainable buildings are often able to save electrical energy but do not necessarily reduce peak demand.

When sustainable building features are effectively designed, built and implemented, peak demand can be reduced so that there is less tendency to expand the electricity grid and have less impact on carbon emissions and climate change. These sustainable features can be good orientation, sufficient thermal mass inside the building, good insulation, photovoltaic panels, thermal or electrical energy storage systems, smart home building energy management systems.

Cost and return

The issue that is criticized about the construction of environmentally friendly buildings is the price. Photovoltaics, new appliances and modern technologies cost more. Most green buildings cost less than 2%, but are 10 times more efficient over the life of the building. Regarding the financial benefits of green building, "Over 20 years, the financial payback is typically 4 to 6 times greater than the additional cost of going green. And the broader benefits, such as reduced greenhouse gas emissions (GHGs) and other pollutants, have a large positive impact on surrounding communities. And planet Earth they have." The stigma is between the knowledge of initial cost versus life cycle cost of saving money from more efficient use of water and electricity, which leads to lower energy bills. It is estimated that the various sectors could save

\$130 billion on energy bills. Also, the higher productivity of the worker or student can be included in savings and deductions.

Setup and operation

As a result of increased interest in green building concepts and practices, a number of organizations have developed standards, codes, and rating systems for use by government regulators, building professionals, and consumers. In some cases, codes are written so that local governments can adopt them as regulations to reduce the local environmental impact of buildings.

Green building rating systems such as BREEAM / UK, LEED / USA and Canada, DGNB / Germany, CASBEE / Japan, and VERDE GBCe / Spain, GRIHA / India help consumers determine the level of environmental performance of a structure. They award points for optional building features that support green design in categories such as building site location and maintenance, conservation of water, energy and building materials, and occupant comfort and health. The number of units generally determines the level of success.

Green building codes and standards, such as the International Code Council's draft International Green Building Code, are a set of rules created by standard development organizations that establish minimum requirements for green building elements such as materials or heating and cooling.

Some of the main building environmental assessment tools that are currently in use are:

- United States: International Green Construction Code (IGCC)

Green neighborhoods and villages

At the beginning of the 21st century, efforts were made to implement green building principles, not only for individual buildings, but also for neighborhoods and villages. The goal is to create zero-energy neighborhoods and villages, meaning they generate all the energy on their own. They also reuse waste, implement sustainable transport and grow their own food.

International assessment frameworks and tools

IPCC Fourth Assessment Report

Climate Change 2007, Fourth Assessment Report (AR4) of the United Nations Intergovernmental Panel on Climate Change (IPCC), is the fourth in a series of such reports. The IPCC was created by the World Meteorological Organization (WMO) and the United Nations Environment Program (UNEP) to assess scientific, technical and socio-economic information about climate change, its potential impacts and adaptation and mitigation options.

UNEP and climate change

UNEP's United Nations Environment Program works to facilitate the transition to low-carbon societies, support climate resilience efforts, improve understanding of the science of climate change, and raise public awareness of this global challenge.

GHG indicator

Greenhouse Gas Index: UNEP Guidelines for Calculating Greenhouse Gas Emissions for Businesses and Non-Business Organizations

Agenda 21

Agenda 21 is a program implemented by the United Nations related to sustainable development. This comprehensive plan is an action that should be taken at the global, national and local levels by UN agencies, governments and major groups in every area where humans affect the environment. The number 21 refers to the 21st century.

PSM FIDIC

The International Federation of Consulting Engineers (FIDIC) Project Sustainability Management Guidelines were developed to assist project engineers and other stakeholders in setting sustainable development goals for their projects that are recognized and

accepted by community interests. This process also considers It is to enable the alignment of project objectives with local conditions and

priorities and to help those involved in managing projects to measure and verify their progress.

Project sustainability management guidelines are structured with themes and sub-themes under the three main headings of social, environmental and economic sustainability. For each individual subtopic, a main project indicator is defined, along with guidance on the relevance of that topic in the context of a separate project.

The Sustainability Reporting Framework provides guidance for organizations to use as a basis for disclosing their sustainability performance, as well as providing stakeholders with an applicable and comparable framework for understanding the information disclosed worldwide.

The reporting framework includes the core product of the Sustainability Reporting Guidelines, as well as the Department's protocols and supplements. The guidelines are used as the basis for all reports. They are the foundation on which other reporting guidance is built and define core reporting content that is broadly relevant to all organizations regardless of size, sector or location. The guidelines include principles and guidance as well as standard disclosures (including indicators) to outline a disclosure framework that organizations can adopt voluntarily, flexibly and incrementally.

Protocols underlie each index in the guidelines and include definitions for key terms in the index, compilation methodology, target scope of the index, and other technical references.

Sector supplements address the limitations of a one-size-fits-all approach. The sector supplements complement the use of the core guidelines by capturing the unique set of sustainability issues faced by different sectors such as mining, automotive, banking, government agencies, etc.

IPD environmental code

The IPD Environmental Code was launched in February 2008. This code is intended as a global standard of good practice for measuring

the environmental performance of corporate buildings. It aims to accurately measure and manage the environmental impact of

corporate buildings, enabling property managers to generate high-quality, comparable performance information about their buildings anywhere in the world. This code covers a wide range of building types (from offices to airports) and aims to inform and support the following.

- Creation of environmental strategy
- Introduction to real estate strategy
- Transfer of commitment to improve the environment
- Create performance goals
- Environmental improvement plans
- Performance evaluation and measurement
- Life cycle assessment
- Acquisition and disposal of buildings
- Supplier management
- Information systems and data population
- Compliance with regulations
- Team and personal goals

IPD estimates that it will take approximately three years to gather enough data to create a robust set of foundation data that can be used in a typical corporate estate.

Energy consumption in green buildings

Buildings and the real estate industry as a whole account for about 30 percent of total global energy consumption, making them the focus of efforts to transition green energy away from dependence on fossil fuels.

Energy-efficient buildings, such as electric and eventually hydrogen-powered cars, are a necessary step for the future of our

planet, especially because of the ongoing urbanization process, with an estimated 70% of the world's population living in cities by 2050.

New construction green buildings

Key factors to consider in building energy efficiency include building orientation and footprint, but there we step into the realm of site planning and selection, architecture and engineering. So beyond new constructions, how can we help as green building consultants to renovate our existing buildings.

Renovation of green buildings

General strategies in the renovation project include reducing energy demand, increasing resource efficiency, and tracking the live energy consumption of the building. Together these provide the building blocks of efficient retrofitted buildings. Of course, the ideal goal is net zero or net positive buildings.

In particular, demand can be reduced through strategies such as passive design and green roofs. For example, energy resource efficiency can include implementing efficient lighting, efficient HVAC, and elevator systems, as well as on-site renewable energy generation through rooftop solar panels.

By incorporating some or all of these energy reduction green building strategies, there is a need to continuously track and monitor energy efficiency progress so that facility management has a real-time picture of building energy consumption patterns.

Decreased demand in green buildings

Demand reduction in sustainable green buildings includes strategies that reduce initial energy needs, reduce the amount of energy consumed, and generally pave the way for greater energy efficiency. Passive design as well as the implementation of green and cool roofs are several strategies to reduce energy demand.

Passive design in sustainable buildings

Passive design is a concept where sustainable building design works with local climate conditions to reduce the need for energy use.

Passive design includes strategies such as daylighting, natural ventilation, and passive heating, all of which can reduce energy

demand. All this is done in the building modeling phase of a new construction project.

Green roofs and cool roofs in sustainable buildings

Green roofs and cool roofs in sustainable buildings Rooftops are often an untapped resource in buildings, when in fact they have great potential to reduce energy demand. The roofs are exposed to the highest amount of solar radiation in the entire Costanzo building envelope. Cool roofs use a highly reflective coating such as white paint to increase reflectance, while green roofs use vegetation to increase the building's cooling capability. Although green roofs and cool roofs have advantages and disadvantages, both reduce the cooling demand of the building. provide Green roofs provide additional benefits such as air purification and biophilia benefits if they are made available to building occupants. But due to the green space maintenance factor, the implementation of cool roofs is easier in terms of initial investment.

Energy efficient lighting in sustainable buildings

One of the low-consumption ways for energy efficiency is to use low-consumption lights such as LED lamps. Overall, this is a very inexpensive intervention that can provide significant energy savings. Such lamps use more than three times less energy than fluorescent lamps and less than one seventh of the energy used by incandescent lamps. Additionally, LEDs offer a higher lumen output that increases safety and visibility, as well as a much longer lifespan.

Production of renewable energy in green buildings

In addition to incorporating energy-efficient appliances and devices, the use of renewable energy and its production potential on-site is a very effective green building strategy. Solar is the most common and easily accessible renewable energy source on a building site.

The panels are usually placed on roofs and must be angled to receive the best sunlight, which varies depending on the location and orientation of the building. However, newer technologies offer

ways in which, for example, solar technology can be incorporated into facades.

Benchmark, track and monitor green building energy

Once a green building energy efficiency plan is implemented, there is a need to monitor the building's energy consumption to track ongoing performance. Several third-party organizations such as ASHRAE, ANSI, and IESNA offer foundation lines. For example, ASHRAE 90.1-2010 is an energy efficiency standard.

After establishing the baseline and setting the goals, a process called commissioning is implemented. This process, as described in the LEED Green Building Standard, is the process of verifying and documenting that a building, all of its systems, is planned, designed, operated, and maintained to meet the owners' project requirements.

This concept encourages projects to continue operating according to their original objectives and control energy consumption to maintain desired efficiency levels.

This concept encourages projects to continue operating according to their original objectives and control energy consumption to maintain desired efficiency levels.

Installing sub-meters and automated building controls allows building operations managers to track costs and energy consumption by area and also helps control energy consumption in the building. Building Energy Management Systems (BEMS) are common systems used to monitor and control building energy consumption.

Net energy in green buildings

Our ultimate goal as real estate sustainability consultants is to create net positive energy buildings, meaning that more energy is generated on site from renewable sources than the building consumes. So instead of receiving energy from energy sources, we give energy back to them.

Net zero energy buildings, a relatively more attainable yet challenging goal, produce the same amount of energy on site as they

consume, avoiding the depletion of energy resources, and even achieving that is no easy feat! Achieving that requires systems thinking, looking at a building from a foundational perspective, and examining how the system's distinct elements can work together to create a more efficient whole.

National Building Regulations

A set of regulations under the title of National Building Regulations and Urban Architecture Regulations has been compiled with the aim of monitoring the safety and quality of construction and maintaining the integrity of the urban landscape in the country, the correct implementation of which is mainly under the authority of the Building Engineering System Organization, municipalities and similar organizations. They are dependent.

Construction standards are mainly in two categories related to building and architecture-urban planning. The topics related to the building include things such as the resistance and strength of the structure, fire safety, the type of materials, distances, etc., and the laws related to urban planning are often related to the permitted height of construction, respect for privacy.

Rules of urban planning and construction

Laws and regulations of density and high-rise construction of buildings:

The Supreme Council of Urban Planning and Architecture of Iran, in the meeting dated 24/10/1369, in order to optimally and optimally use the surface of the land in cities for population settlement, providing open space and a better environment in coordination with the resolution dated 1/07/1369 of the Council of Economy regarding the reduction of the surface The infrastructure of residential units with an emphasis on general policies, encouraging high-rise construction, adapting the separation model to the requirements of high-rise construction, using capacities with the increase in population and building density, measuring mass and using industrial methods in building goals and plans. It was

approved that the commissions of Article 5 of the Law on the Formation of the Supreme Council of Urban Planning and

Architecture are required to revise the preferential plans and its executive regulations in all cities with a population of over 200,000. Census of 2015 according to the following materials:

- 1: The communication network system must be maintained based on the community plan, and in case of major changes with the city, its approval will be the responsibility of the Supreme Council of Urban Planning and Architecture of Iran.
- 2: Determining residential and mixed residential areas with high density, tall buildings and at least 6 floors other than land in non-dense areas.
- 3: Determining residential and mixed residential areas for high-rise construction (at least 9 floors apart from the ground) in the renovation of worn and old structures, small parts that have not been built, to use the increase in density. It is necessary to collect small plots of land as needed for high-rise construction
- 4: Determining residential areas (1 or 2 households) with a maximum height of 2 floors other than the basement.
- 5: Determining the maximum occupation level in high areas.
- 6: Determining the criteria for separation and density of buildings in high-rise areas with the observance of at least 1000 square meters of area and the criteria to encourage the increase in density in contrast to the increase in the level of parts and the decrease in the level of employment.

A 45-degree view from the height of buildings with two or more doors with passages less than 30 meters in the passage at the height of the foundation lot + two floors is allowed, and 3.5 meters must be retreated from the third floor. From the passage as per norms, the length of the passage which has been increased should increase the height and if the height again exceeds 32 meters, it should be set back by 4 meters for each floor. If the width of the street is between 12 and 30 meters, there is no height limit. If the width of the street was between 7 and 12 meters, the height of each additional floor space should be reduced by 4 meters.

Regulations related to the progress of construction in crossings:

The advance payment is calculated from the extension that was determined for the buildings even if the building is not in this extension. The length of the projection of each building on each floor distinguishes the percentage of the infrastructure of that floor. If the adjacent block is built or constructed, 60%, if more is built, it can be considered 2+60% building (infrastructure) and if the adjacent block is less than 60%, it can be built after 60 . % with an angle of 45 degrees up to two meters. It is forbidden to install doors and windows above the surface of the facade when opening. Pouring water from the gutter on the sidewalk is prohibited and must pass below the surface of the sidewalk. It is forbidden to install the heater pipe on the external wall overlooking the passage or its exit from the wall. It is forbidden to install stairs in front of the extension of the building unless it is necessary due to the change of the street level and with the approval of the municipality. In streets of more than 8 meters, the number of occurrences is 1.2 of the width of the sidewalk and a maximum of 1.20 meters, and the height should not be less than 3 meters. The console at a height of 2.4 meters, like the foundation lot, should not be more than 1.3 times the width of the sidewalk and a maximum of 60 meters. The sidewalk is 1/6 the width of the street. If the terrace is open on both sides, half of the area is considered as floor level. If the terrace is closed on both sides, 2/3 of its area is part of the floor surface. If the terrace is blocked on all sides by walls or glass, it is part of the infrastructure.

Parking rules and regulations:

The required number of parking spaces will be 70% of the number of permitted units. The parking ramp is designed in the open space of the building and is not part of the infrastructure. The maximum height of the parking lot is 2.04 meters and the minimum height of the entrance is 1. It is 80 meters. Parking in the basement must have direct access to the floors. The slope of the ramp is 17% (maximum), the parking space for each car is 5.2 x 5.5 meters,

including the space suitable for commuting (standard), the minimum width of the ramp to access the residential parking lot. 2. 5 meters and commercial entrance 5. It is 3 meters. In the parking

lot, the distance between AX and AX columns on the ground floor or underground is at least 5.5 meters. A parking lot is required for both residential units. If there is a garage, at least 16 square meters of parking space and two garages are required for each license plate. In 4-unit apartments, two parking spaces (one for each two units) are required. A parking space is required for each additional unit and the area of each parking space is at least 25 square meters.

City view rules and regulations

- 1: All visible surfaces of buildings located within the boundaries of cities and towns that can be seen from inside the roads. Whether it is the main facade or the side facade, it is considered urban, the facade should be made with high-quality materials in a suitable, beautiful and harmonious way.
- 2: The issuance of the certificate of completion of the construction work is conditional upon the completion of the main and secondary facades.
- 3: In all cities with a comprehensive and priority plan, it is necessary to prepare and approve the plans within 6 months from this date.

Regulations related to the shape and façade of the building:

The importance of the shape and appearance of the building in the urban landscape has caused a part of the general regulations of the building to deal with this issue. What should be the standard shape of the building in our country? According to general building laws and regulations, the design and implementation of buildings should be such that they do not harm the street view, the neighborhood, cultural and natural effects, and the valuable features of the environment. The building plans should be in such a way that the form, the scale, materials, color ratio and volume should be in harmony with the surrounding environment. Therefore, if there is a building being built around you, which is considered an awkward patch according to any of these rules, you can object to its construction, because one of the general rules of the building must

have been violated. The signs and sculptures in the city must also comply with these conditions and adapt to their surroundings. The

institution that oversees this matter will be the final reference building to decide whether or not to comply with the above standards. But the more important issue is related to the safety of construction materials and construction products. What characteristics should these materials have?

Regulations for the construction of different parts of the building

Yard

The width of Hayat Khalut is 2 meters and its area is 12 square meters, which is not considered part of the infrastructure. If its width is less than two meters or its area is less than 12 square meters. A part of the infrastructure is considered on the floor that is a private yard. In apartment units with more than 5 rooms (kitchen, dining room, living room and bedroom), it must have at least 12 square meters of light with a minimum width of 2 meters. In buildings with more than 5 floors, the rooms should receive light properly. The minimum yard area of the institutional and light-receiving yards must be 4 square meters, and the yard area is considered part of the building. The windows overlooking the neighbor in the private courtyards should be halved from the first floor to after 1/7.

Escalator and elevator

There is no need for elevators and escape stairs in buildings with foundation lot and four floors on foundation lot. In 5-story buildings, if the 4th and 5th floors are duplexes, there is no need for elevators and escape stairs. Escape stairs and elevators are required in buildings with more than 5 floors.

Paving The amount of paving at the main intersections is equal to one tenth of the sum of the two widths of the intersection. The amount of paving in the plaques adjacent to the passageways with a width of ten meters and less to the passages of more than ten meters is two meters. The intersection of the side street with the amount of main paving is two tenths of the width of the side street.

Regulations for the construction of residential complexes

- 1: The total area of the infrastructure of residential units is allowed to be 120% of the maximum land area.
- 2: Gross land per capita for each residential unit is at least 100 square meters.
- 3: The area of the smallest residential unit should not be less than 80 square meters.
- 4: The maximum allowed occupation level on the ground floor is equal to 35% of the total land area. Security infrastructure levels, greenhouses, showers and changing rooms and toilets and swimming pools and indoor recreational areas for children are not responsible for the above scope.
- 5: It is mandatory to build a parking lot for at least 75% of the number of residential units.
- 6: The minimum net area of the park for each car is 12.5 square meters.
- 7: The minimum width of access roads to parking lots should be 5.5 meters.
- 8: The total occupied surfaces of residential building infrastructure on the ground floor, in addition to the occupied surface of car passages and parking lots, should not be more than 60% when parking is planned in the open area. of the entire surface of the earth.

Municipal rules and important points in building design

Placing a parking space with a minimum opening of 2.5 meters.

Placing two parking lots next to each other with a minimum opening of 4.5 meters.

Placing three parking lots next to each other with a minimum opening of 7 meters.

The required length for the park is 5 meters.

The minimum parking space is 2.5 x 5 meters.

The turning radius or desired length for the maneuver is 5 meters.

The minimum width of the parking lot entrance is 3 meters.

The width of the one-way ramp is 3 meters and the two-way ramp is 6 meters.

The width of the one-way arc ramp is 3.65 meters and the two-way ramp is 7 meters.

The inner radius of the circulation path in all parking lots is 4.57 meters.

The slope of the parking ramp is 15%.

Each unit above 100 meters on the first and second floor needs a parking space.

A residential unit smaller than 150 meters, one parking space - 150 to 200 meters, 1.5 parking spaces - more than 200 meters, two parking spaces, and if the number of units is odd, one unit is exempt from parking.

The maximum useful height of the residential unit is 2.90 meters.

The maximum parking height is 2.20 meters.

The maximum useful height of the pilot is 2.40 meters.

The maximum height of the basement is 2.20 meters.

The maximum useful height of the business unit is 4.50 meters.

The minimum useful height of the parking lot entrance 1. It is 80 meters.

Useful height of the truss 2. It is 20 meters.

The height of lighting in the basement is maximum 90 cm.

The minimum area of the window should not be less than one fifth of the area of the space.

The minimum width of private life is 2 meters if it is all-sided and 3 meters if it is not all-sided.

It is allowed to build a projection or balcony in the passage of 12 to 20 meters 80 cm and in the passage above 20 meters 120 cm.

The height of this development from below it to the street is 3.50 meters, the minimum width of the kitchen and bedroom is 2.50 meters, the living room is 3.00 meters and behind it is 1.20 meters.

Kitchen and reception lighting is allowed from the window, provided that the length of the light is less than 8 meters.

The dimensions of the skylight for the bedroom and living room are 3x4 meters and for the kitchen 2x3 meters.

The useful dimensions of the elevator are 2 x 1.60 meters.

The minimum height of the elevator pit is 1.50 meters.

Organization:

A person or group of people who have specific tasks with responsibilities, authority and relationships to achieve their goals.

Note 1 of the entry: The concept of organization includes a sole trader, company, joint-stock company, firm, institution, reference, partnership, charity or institution or a part or a combination of them, whether private or non-governmental.

Note 2 Entry: This is one of the common terms and the main definitions for ISO management system standards are given in Annex SL of the ISO Supplement to the Consolidated ISO/IEC Directives, Part 1.

The purpose of developing national building regulations

National building regulations require designers to design and calculate according to the engineering principles contained in it. Furthermore, these regulations, in addition to supervising the basic construction of buildings, oblige the builders to observe safety and health in the individual area. In other words, the national building

regulations have been compiled in order to ensure the safety, health, and health of the people of the society. In addition, the construction

of buildings in compliance with these regulations will have their engineering in the foundation.

Compliance with these rules during construction will lead to maintaining the health of the builders and after construction will increase the quality and life of the buildings. In case of full compliance with these regulations, the residents of the buildings will also benefit from many of its advantages such as thermal and acoustic insulation of the buildings. Although in some cases these regulations appear to be cumbersome and increase construction costs, in general, by reducing energy consumption, reducing maintenance costs and renovation costs, it will impose a lower overall cost on the main consumer.

One of the requirements to comply with these regulations is the use of standard materials and products. This, in turn, leads to the standardization of products related to the construction industry and construction materials.

National building regulations and other regulations and standards

The obvious difference between the national building regulations and other technical documents and regulations is the necessity of their implementation throughout the country, which leads to the establishment of unity in the construction industry. On the other hand, this requirement has caused that, unlike other regulations and instructions, there is no guidance and recommendation in the text of these regulations. National building regulations are not specific to a specific region or territory.

The scope of national building regulations in society

The national building regulations govern all operations related to the building, from demolition to renovation, major repair, development and construction. These regulations are not specific to building engineers, rather, as the title suggests, they are building regulations and all those who have any connection with the building should be familiar with them and have received training, however minor, in this regard. Foundational training of these positions from

the lowest to the highest level of society will guarantee the goals of their formulation in the foundation. In other words, in order to

achieve the drawn goals, the gap in the education system regarding the national building regulations should also be resolved. The construction engineering system, as the main body for the application and control of these regulations, must have a written program in its education and promotion.

National building regulations and engineering system tests

These regulations are one of the sources of construction engineering system exams to meet the conditions of employment in civil engineering, architecture and facilities fields. But it seems that all the engineers who get a passing grade in this test are not ready to apply and control these regulations as the executive arms of the engineering system. Familiarizing with a list of fifty percent of the regulations, and the high speed of action in finding answers to questions will not lead to engineering training ready for work.

The commercial use of these regulations and the production of keywords is also one of the reasons for the ineffectiveness of the test mechanism in determining and confirming the qualifications of engineers. The result of the conceptual and continuous study in order to apply these regulations in the country's construction field will be the training of engineers who are familiar with the regulations and who will also have a license to work. The weakness of the majority of engineering graduates regarding the national building regulations is mentioned due to the same learning vacuum. Continuous and foundational trainings and tests and updating the information of working engineers should also continue after the tests. It is worth noting that foundation upgrade courses are almost unfamiliar with these regulations and most engineers are completely disconnected from national regulations after the exam.

Executive guarantee of national building regulations

Adjusting the fees of the enforcers and supervisors of these regulations is also the next step in guaranteeing its implementation. As the evidence shows, the current process is largely inefficient and by continuing it, the goals of preparing and compiling national building regulations will not be met.

IMS

The integrated management system is one of the other abilities of every industrial engineer, who by learning it can implement this standard for different factories or organizations.

Integrated Management System (IMS) is a combination of several management system standards registered in its organization. Management systems are developed, implemented and maintained through a system of processes that cover the requirements of each standard.

For example, the processes required in each standard for document control, internal audit, non-conformance handling, corrective action or management review can be shared so that the requirements of each standard can be easily replicated. An example of an integrated management system is one that simultaneously manages the requirements of ISO 9001, the quality management system standard. and ISO 14001, an environmental management system standard, from the International Organization for Standardization (ISO). and OHSAS 18001, occupational health and safety specifications.

IMS planning and development should include identification of risks and opportunities that could affect the organization, including business and quality risks, in addition to those related to health and safety and environmental obligations. Some areas may be easier to integrate than others, and as such, systems may not be fully integrated.

According to the ISO standard, "a management system describes a set of procedures that an organization must follow to achieve its objectives". IMS enables an organization to adopt a process approach to measuring and evaluating its effectiveness in achieving its objectives. A process approach allows senior managers to treat all elements of the management system rather than looking at individual standards, regulations, activities or requirements. High structural alignment at the level of ISO standards facilitates the integration of multiple management systems.

Business benefits of IMS

Where IMS is effectively implemented in the organization's strategy and business direction, it enables senior management to ensure effective leadership and commitment, while reducing repetitive activities and therefore review time. . This leads to cost savings through efficient use of resources at all levels and functions throughout the organization.

In addition to enabling organizations to fully understand business conditions, IMS also enables them to see the obligations and requirements of applicants in each specific sector, taking into account systematic risks and opportunities.

A robust IMS is able to identify potential improvements in all its parameters and provide a more comprehensive view of the entire business (such as quality, environment, and health and safety) than is achieved in individual management systems.

What are the benefits of landscape certification?

IMS implementation has the potential to reduce the duration of external audits compared to separate audits performed for each register. This is due to the focus on integration of common processes and requirements mentioned earlier. Therefore, your assessor may be able to count on several standard requirements when reviewing a particular process or policy. This makes the audit process much more efficient. By reducing the duration of the audit, it reduces internal and external costs related to the audit and also helps to minimize disruption to employees during the audit period.

Evaluation of ideas about integrated management systems

Implementation of IMS is a positive move for organizations compared to shared management systems. It not only complies with the new ISO standards, but also emphasizes the continuous improvement and maturity of the organization. This results in a more efficient process for third party audits and internal auditors due to the consistency and structure of IMS. Evaluators also found that organizations with an IMS typically have a better understanding

of their business objectives in relation to strategies, opportunities, risks and areas for improvement.

Integrated Management System (IMS) implementation steps

Step 1: Awareness and education

Increasing the organization's awareness of the various management systems - and the standards to which they correspond, which are integrated. Holding separate training sessions for top management, middle management and coded management.

Step 2: Policy and objectives

Creating an integrated policy of quality, environment, health safety and information security. Creating organizational goals related to the vision, mission, objectives and strategic direction. Work with senior management on policy development.

Step 3: Internal gap analysis

Identify the degree of compliance of the existing management system with the requirements of the desired standards in your IMS. Understand all operations across the organization and create a process map for all activities. Compare existing operations with the requirements of standards that are being integrated.

Step 4: Documenting and designing the process

Document the process according to the requirements of the relevant standards. Write and implement operational instructions, work instructions, system procedures and related forms.

Step 5: Documenting and implementing the process

Implementation of the processes and documents compiled in the fourth step throughout the organization so that all departments and activities are covered.

Step 6: Internal audit

Implementation of a strong internal audit system Training internal auditors on how to conduct internal audits of the organization covering all departments and operations. Corrective measures have been taken to improve each of the audit sections in order to bridge the gap between the existing processes and the requirements of the standards. It provides IMS functionality.

Step 7: Convening the management system review meeting

Implement a formal system for senior management to review important aspects of the organization's business that are related to integrated standards. Review the following: Policy, including the organization's strategic direction. The goals correspond to both the setting of the goals and the amount of the goals. internal audit results; process performance results; complaint outcomes, feedback and legal compliance; Results of risk assessment and incidents. Develop an action plan to correct any non-conformance with the standards.

Step 8: Complete analysis of the management system gap

Conduct a formal gap analysis to assess IMS effectiveness and compliance prior to final certification. To ensure a high degree of compliance with IMS standards, a close representation of the final certification authority should be made.

Step 9: Corrective measures

Based on gap analysis, conduct audits and determine remedial projects for discovered non-compliance barriers. Ensure that corrective actions are completed and the organization is ready for final certification.

Step 10: Final license audit

The external auditor reviews the IMS audit. In case of non-compliance, the auditor recommends that the organization should comply with the standards recorded in its IMS.

Types of permits and building permits and the information contained therein

- We said earlier that the building permit is a document that is issued by the municipalities to build a building and comply with construction principles and is given to the owner.
- Building permits for barren lands or gardens, demolition and renovation, replacement of engineers, additions, map changes, building development, changes, and conversions are types of building permits that must be obtained from the municipality or urban electronic services offices. The building permit provides the owner with information about the building and its structures, which include:
 - Infrastructure area
 - Number of floors
 - Type of building frame
 - Details of the license applicant (real or legal owner).
 - Property registration plate number
 - Name of supervising engineer or engineers
 - License issuance date
 - Crooky of the earth
- The deadline for starting operations and the validity of the license are generally written on the first page of the issued license, which can be extended if necessary.
- Obtaining the ownership document for each residential unit is related to the completion of the work by the supervisor and the issuance of the completion of the work by the building permit issuing authority.
- If there is a violation by the owner based on the provisions of the license, the supervisor will be obliged to report the violation to the licensing authority in order to prevent the operation from

continuing. Compliance with national building regulations is mandatory in buildings.

Procedures for issuing permits and building permits

- Today, the municipality provides construction applicants with booklets titled building ID, in which the issuance of the building permit, the absence of violations, and the completion of the work can be seen as a whole.
- Building ID includes a lot of information about the identity of the building and all the materials related to the building. Also, the date of issuance of the building permit and land specifications, the location of the building, the identity of the owner and his type of ownership, supervising engineer, calculations and facilities that can be used in the building, four dimensions of the license plate, sketch and land area, residential or commercial use of the building, the density of the building, specifications The floors of the building, the condition of the parking lot, modifications and construction changes, how to renew various fees such as municipal fees and renovation fees, the certificate of non-violation and finally the certificate of completion are among the information that can be seen in the building registration certificate. Therefore, to obtain the necessary permits, the following steps must be taken in order:

1- File filing: In the first stage of the building permit issuance process, the owner or a person who has the power of attorney from the owner must file a request for a building permit in the municipality or the electronic service offices of the city to obtain a building permit. In order to apply for a building permit, the owner must submit the original and photo of the ownership document, the original and photo of a valid identification card such as a national card or birth certificate, as well as the settlement sheet for renovation fees and municipal fees for the current year and previous years to the municipality or the electronic service offices of the city. and register your request in writing in these centers.

2- Visitation order: After filing the case by the owner, the municipal authorities will take over the other procedures of

the case. Therefore, the urban planning official visits the construction site of the property to check the dimensions of the property, the width of the street and the building and the adjacent buildings. This visit will be effective in issuing a license to build the number of new floors of the building. For example, if the size of the house is less than a certain value, the building permit will not be issued for more than four floors.

3- Examining the report of the technical officer and property user: in some big cities like Tehran, a detailed plan is implemented, that is, the construction rules are specified in every part of the city. The expert specifies the detailed plan of the property's use in the comprehensive and detailed plan of the city. In this investigation, if it is determined that the property is located in a plan of the municipality, this issue is examined more carefully to determine whether the construction of the building interferes with the construction projects of the region or not. If an interference is observed, it should be determined how much its density is and then its corrections should be made.

4- Map order: After completing the above steps, the urban planning expert will issue a map preparation order to the owner. In the order of the map, information such as the remaining dimensions of the property after the desired reforms of the municipality, the area of the land after the reforms, the number of floors and the area occupied by each floor are mentioned. Based on this, the volume of the building, i.e. the number of floors and the occupancy level of each floor, is determined according to the area in which the property is located, as well as the size of the document (not the size of the land and width). In the next step, the drawing order is referred to the architect.

5- Map design: at this stage, based on the municipal rules and the issued map order, the architectural map is designed for the property. Designing an architectural plan is one of the most important stages of issuing a building permit, because the maximum potential of the plan in terms of size, number of

parking spaces, and quality of spaces is presented in it. After designing the architectural plan, it should be sent to the municipality or city service offices to be checked. If the architectural map needs to be modified, the engineering office is required to modify the map and after the modification, the map is again referred to the engineering service offices to receive the approval of the map.

6- Payment of municipal fees: After the finalization of the architectural plan and the removal of the defects mentioned by the municipal services offices, the renovation fees and also the municipal fees are calculated and determined by the building permit issuance unit based on the available floor area and type of building use.

7- Preparation of draft documents: after paying the municipal fees and receiving the approval of the revenue department of the municipal district regarding the payment of municipal fees and renovation fees, the draft documents must be prepared. To prepare the draft, the owner must go to the municipal service offices and complete the application form for appointing a supervisor. Then he should wait for the supervisor to be called and introduced by the service offices. After appointing the supervisor, a contract is signed between the owner and the supervisor. Then, their quota sheets must be delivered to the electronic service offices along with the agreement between them as a supplementary criterion for the draft license. Also, the owner must prepare the obligation to comply with the amendment and the obligation to obtain the approval of the facade. If the infrastructure of the building has an area of more than 2000 square meters, it will be subject to the implementation of Article 33 of the building engineering system. Therefore, the approval of the structural plans, the approval of the soil mechanics test report, and the approval of the electrical and mechanical facility plans should be obtained from the engineering organization.

In total, the draft documents that must be prepared by the owner and submitted to the service offices are: a green card stamped in 4 disciplines including structure, architecture,

electricity and mechanics, a green card or supervisor's quota along with the owner and supervisor contract, a commitment sheet to comply with the amendment and Façade approval, structural plan files, electrical and mechanical plans, checklists for topics 19 and 6, loading and earthquakes, geotechnical consulting commitment sheet and soil approval.

8- Permit printing: after the approval of the maps of the four disciplines and the process of obtaining the approvals of the urban services office and the approval of the detailed floor plan, the approval of the head of building permit issuance, the vice president of urban planning and architecture, and finally the approval of the mayor is needed, and all these approvals are done systematically. And as a result, the building permit is printed.

Building permit validity period

- The thing that should be taken into consideration after receiving the building permit is that the building permit is valid for 2 years from the date of its issuance.
- The duration required for the construction of all construction projects is announced based on their size, and if the owner cannot complete the construction within this period, he will be warned first and then he will be subject to deferred charges.
- The deadline for each stage of construction operations is determined according to the size and number of floors in a table. As a general measure, the construction of a building is considered to be about 4 years.

Since the municipality has considered enough time to renew the building permit, it will not be possible to renew the building permit after the end of this period.

- After the allowed period for the construction of the building, the owner will be required to obtain a new construction permit and pay

20% of the permit calculations at the daily rate. In this case, the municipality will extend the previous license for a period of three years.

- If during construction, due to various reasons, the initial architectural plan is changed, a file must be filed in the urban electronic services offices and the same procedures as the initial permit issuance must be followed in order to issue a new permit.
- If, during the implementation of the addition, an excess of the area mentioned in the permit is observed, the owner must go through the steps of the certificate of non-violation, and if it does not exceed the permitted values of the municipality, he must pay municipal fees for the additional area, so that the certificate of non-violation is issued to him.
- If the illegal size is more than the allowed amount approved by the municipality, the problem is not solved by paying the municipal fees and the issue is brought up in the municipality's Article 100 Commission, and usually the vote will be given to demolish.

International building code

The International Building Code (IBC) is a model building code developed by the International Code Council (ICC). It has been adopted for use as the foundation code standard by most jurisdictions in the United States. The IBC addresses the health and safety concerns of buildings based on relevant regulatory and performance requirements. The IBC is fully compatible with other published ICC codes. Code provisions are intended to protect public health and safety while avoiding unnecessary costs and preferential treatment of certain construction materials or methods. However, in 2019, The New York Times revealed the story of a secret deal with the National Association of Home Builders that would have allowed the trade group that represents the construction industry to push for reforms to rules that would make buildings more environmentally sustainable. It makes it more resistant to natural disasters, limits, and this prompted congressional investigations. The ICC, in response to a congressional inquiry, strongly rejected this characterization of the agreement, noting that: While homebuilders are among our partners in [our code development], they have

disproportionate control over the Code Council's model code development process. Conversely, volunteer government officials

with experience and expertise exert the greatest control over the process.

Reference standards

Model building codes rely heavily on reference standards published by other standards organizations such as ASTM International, ANSI (American National Standards Institute), and NFPA (National Fire Protection Association). Structural regulations rely heavily on referenced standards, such as Minimum Design Loads for Buildings and Structures published by the American Society of Civil Engineers (ASCE-7) and the Specification for Steel Frame Buildings by the American Institute of Steel Construction (ANSI/AISC).

Changes in parts of the reference standard can lead to disconnection between the respective versions of the reference standards.

Copyright discussion

Many states or municipalities in the United States have adopted the ICC family of codes. In the foundational federal copyright case of *Veeck v. Southern Building Code Congress Int'l, Inc.*, a public resource organization, has published a significant portion of the approved building codes online, and they are available in PDF format.

In 2017, the ICC sued a private, for-profit company called UpCodes in response to that company's posting of copies of ICC model codes. After discovery, Judge Victor Marrero ruled against UpCodes on many of the ICC's claims of copyright infringement, holding that because UpCodes was uploading the codes as statutory codes, the government's injunctive relief doctrine It prevented the ICC from enforcing its copyright on model codes. To block the upload after the trial order, the ICC sued in a separate action, alleging false advertising and claims of unfair competition. That separate lawsuit was dismissed in 2021.

ICC building codes

- International Building Code (IBC)
- International Residential Code (IRC)
- International Fire Code (IFC)
- International Plumbing Code (IPC)
- International Mechanics Code (IMC)

International Fuel Gas Code (IFGC)

- International Energy Conservation Code (IECC)
- ICC Performance Code (ICCPC)
- Wildland International Urban Interface Code (IWUIC)
- International Existing Building Code (IEBC)
- International Property Management Code (IPMC)
- International Private Sewage Disposal Code (IPSDC)

International Zoning Code (IZC)

- International Green Construction Code (IgCC)
- International Swimming Pool and Spa Code (ISPSA)

Building code

The building code is a set of rules that specify the standards of built objects such as buildings and non-building structures. Buildings must comply with the code to obtain planning permission, usually from the local council. The primary purpose of building codes is to protect public health, safety and welfare as it relates to the construction and occupancy of buildings and structures. A building code becomes the law of a particular jurisdiction when it is formally adopted by the appropriate public or private authorities.



Code Violation: This fire rated concrete block wall is penetrated by cable trays and electrical cables. The hole must be fire sealed to restore the fire resistance rating of the wall. Instead, it is filled with flammable polyurethane foam.

Building codes are generally intended for use by architects, engineers, interior designers, builders, and regulators, but they are also used for a variety of purposes by safety inspectors, environmental scientists, real estate developers, subcontractors, manufacturers of building products and materials, insurance companies, and utilities. . Managers, tenants and others. The rules for the design and construction of structures will be regulated if the law is passed.

Examples of building codes began in ancient times. In the United States, the main codes are the International Building Code or IBC/IRC International Residential Code, electrical and plumbing codes, and mechanical codes. Fifty states and the District of Columbia have adopted I-Codes at the state or jurisdiction level. In Canada, national model codes are published by the National Research Council of Canada. In the UK, compliance with building regulations is monitored by building control bodies, either approved inspectors or local authority building control departments. Building Control Regulatory Fees apply where work is being done that would otherwise have been inspected at the time of the work.

The purpose of building codes is to provide minimum standards of safety, health and public welfare, including structural integrity, mechanical integrity (including sanitation, water supply, lighting and ventilation), means of exit, fire prevention and control, and energy conservation. Building rules in general are:

- Structural standards, location, size, use, wall assemblies, fenestration size/location, egress rules, room size/location, foundations, floor assemblies, roof structures/assemblies, energy efficiency, stairs, and Halls, mechanical, electrical, plumbing, drainage and site storage, home appliances, lighting, equipment standards, occupancy rules and swimming pool regulations.
- Parking rules and traffic impact
- Fire code rules to minimize the risk of fire and ensure safe evacuation should such an emergency occur
- Requirements for resistance to earthquakes (seismic code), hurricanes, floods and tsunamis, especially in disaster-prone areas or very large buildings where failure is catastrophic.
- Requirements for specific uses of the building (e.g. storage of flammable materials or accommodation of large numbers of people)
- Energy supply and consumption
- Grandfather clauses: Unless the building is being renovated, the building code usually does not apply to existing buildings.
- Specifications of parts
- Allowed installation methods
- Minimum and maximum room ceiling height, outlet size and location
- Competence of people or companies doing the work
- For tall structures, anti-collision markers in favor of air foundations

Building codes are generally separate from zoning laws, but exterior restrictions (such as setbacks) may fall under both categories.

Designers use building code standards outside of significant reference books during design. Building departments review plans submitted to them prior to construction, issue permits [or not], and have inspectors verify compliance with these standards on site during construction.

There are often additional codes or sections of the same building code that have more specific requirements that apply to homes or places of business and certain construction objects such as canopies, signs, walkways, parking lots, and radio and television antennas.

Energy codes

Current energy codes in the United States:

US energy codes are adopted at the state and city levels and are based on the International Energy Conservation Code (IECC). Previously, they were based on the Model Energy Code (MEC).

As of March 2017, the following housing codes have been partially or fully adopted by states:

- IECC 2015 or equivalent (California, Illinois, Maryland, Massachusetts, Michigan, Pennsylvania, New Jersey, New York, Vermont, Washington)
- IECC 2012 or equivalent (Alabama, Connecticut, Delaware, District of Columbia, Florida, Iowa, Minnesota, Nevada, Rhode Island, Texas)
- IECC 2009 or equivalent (Arkansas, Georgia, Idaho, Indiana, Kentucky, Louisiana, Montana, Nebraska, New Hampshire, New Mexico, North Carolina, Ohio, Oklahoma, Oregon, South Carolina, Tennessee, Virginia, West Virginia, Wisconsin)
- 2006 IECC or equivalent (Utah)
- 2006 IECC or no state code (Alaska, Arizona, Colorado, Kansas, Maine, Mississippi, Missouri, North Dakota, South Dakota, Wyoming)

Historical Energy Codes in the United States:

2005

As of September 2005, the following residential energy codes have been partially or fully adopted by states:

- 2003-2004 IECC or equivalent (Alaska, Arkansas, California, Connecticut, Idaho, Kansas, Nebraska, Maryland, Montana, New Mexico, Ohio, Pennsylvania, South Carolina, Utah, Virginia, Washington)
- 1998-2001 IECC or equivalent (Alabama, Delaware, District of Columbia, Florida, Georgia, Kentucky, Michigan, New Hampshire, New York, North Carolina, Oregon, Texas, Vermont, West Virginia, Wisconsin)
- 1998 IECC (Hawaii, Indiana, Iowa, Louisiana, Massachusetts, Minnesota, New Jersey, North Dakota, Tennessee)
- No statewide/weaker codes (Arizona, Colorado, Illinois, Maine, Mississippi, Missouri, Nevada, Oklahoma, South Dakota, Wyoming)

2004

As of January 2004, the following residential energy codes have been partially or fully adopted by states:

- 2003 IECC or IRC (Kansas, New Mexico, Utah)
- 2000 IECC or IRC or equivalent (Alabama, California, Idaho, Florida, Georgia, Kentucky, Maryland, New Hampshire, New York, North Carolina, Ohio, Oregon, Pennsylvania, Rhode Island, South Carolina, Texas, Virginia, Washington, West Virginia, Wisconsin)
- 1998 IECC (Oklahoma)
- 1995 MEC or equivalent (Alaska, Connecticut, Hawaii, Massachusetts, Louisiana, Minnesota, New Jersey, Vermont)
- 1993 MEC or equivalent (Delaware, Montana, North Dakota)
- 1992 MEC or equivalent (Arkansas, Indiana, Iowa, Tennessee)

- No code or code that does not comply with EAct (Arizona, Colorado, Illinois, Maine, Michigan, Mississippi Foundation, Missouri, Nebraska, Nevada, South Dakota, Wyoming)

2000

As of fall 2000, the following residential energy codes have been partially or fully adopted by states:

- 2000 IECC Legislation (Maryland, New York, Pennsylvania, South Carolina)
- 1995 MEC or equivalent (Alaska, California, Connecticut, Florida, Georgia, Hawaii, Louisiana, Massachusetts, Minnesota, New Hampshire, North Carolina, Ohio, Oklahoma, Oregon, Rhode Island, Utah, Vermont, Virginia, Washington, Wisconsin, Wyoming)
- 1993 MEC or equivalent (Alabama, Delaware, Kansas, Montana, North Dakota)
- 1992 MEC or equivalent (Arkansas, Indiana, Iowa, Kentucky, New Mexico, Tennessee)
- No code or code not in compliance with EAct (Arizona, Colorado, Idaho, Illinois, Maine, Michigan, Mississippi, Missouri, Nebraska, Nevada, New Jersey, South Dakota, Texas, West Virginia)

1998

As of 1998, three states (Ohio, Michigan, and Virginia) had adopted the 1993 MEC Residential Energy Code.

Chapter Four

Housing market in the world economy

Housing is an essential part of the economy, but it has also been a source of vulnerabilities and crises. Hence, while the recent recovery in global housing markets is a welcome development, we must guard against another unsustainable boom.

Detecting overvaluation in housing markets is still more of an art than a science. Broad measures, such as housing price-to-rent ratios, provide the first license. But careful analysis and judgment is required to make a call on overvaluation. The set of policy tools to manage the housing boom is still under construction. Various tools have been used, and evidence suggests short-term success. But more analysis and sharing of experiences about what works and what doesn't is needed. Such conferences are useful to add to our knowledge.

On these three points, let me start with the role of the housing sector. Food, clothing, housing: these are traditionally considered as basic human needs. Therefore, the housing sector fulfills an essential need. Of course, housing is also an important part of investment. And in many countries, housing is the largest component of wealth. For example, in the United States, real estate accounts for approximately one-third of all assets held by the nonfinancial private sector. Most households tend to hold wealth in the form of their homes rather than financial assets. For example, in

France, less than a quarter of households own shares, but nearly 60% of them own houses.

Housing also plays other key roles. For example, mortgage loan markets are important in the transmission of monetary policy. Adequate housing can also facilitate labor mobility within an economy and help economies adjust to adverse shocks. In short, a well-performing housing sector is critical to the overall health of the economy. And as economies develop, we expect a corresponding deepening and growth of the housing market. Despite its importance, the housing sector has not received enough attention from macroeconomists. As Ed Limmer once pointed out, the leading textbooks in this field often did not mention the housing sector at all. Of course, things have changed since the Great Depression. The bursting of the US real estate bubble was followed by the deepest global recession since the Great Depression. It reminds people of the collateral damage that can result from housing collapse.

In fact, throughout history, housing booms and busts have often been detrimental to financial stability and the real economy. Many major episodes of banking problems have been accompanied by boom and bust cycles in property prices. International Monetary Fund research shows that nearly 50 systemic banking crises in recent decades, more than two-thirds have been associated with boom-and-bust patterns in housing prices. The cost of solving the housing crisis can be very high - For example, in the case of Ireland, government financial assistance to banks from the housing collapse increased 40% of the country's GDP. Unlike housing cycles, boom and bust cycles in stock prices are much less likely to trigger systemic banking crises. Even when housing bust doesn't have much of an impact on financial stability, it can affect the real

Principles of design and architecture

The "architectural design principles" of a system are often discussed (or just "architectural principles"). However, without a precise definition of the term "principle", it is not always clear what this

entails. We can use a very useful strategy by describing the role and benefits of design architecture principles.

An overview of architectural design principles

Principles of architectural design are principles of concepts that are incorporated into the architecture of a structure or a whole concept system to create specific results.

What are the principles of architectural design?

In short, the principles of architectural design are the synthetic and technical methods we use to produce architectural designs. which architects use to achieve their visual goals or objectives.

Defining the principles of architectural design

In the case of modern designs, the principles generally differ based on different schools of thought and individuals such as architects or residential designers. There really is flexibility and rigor for architects to use in their work.

The importance of architectural design principles

The principles of design architecture ensure that your designs of buildings meet the aesthetic element.

They ensure that the building looks aesthetically pleasing. When a person looks at that building, he feels the beauty, the prominent things of the building.

They can understand your fundamentals about your buildings and works, so viewers don't have to wonder what your architectural designs mean.

Architectural design principles should help set boundaries and priorities without micromanaging how people perform tasks.

Principles of architectural design help architects know what to prioritize and set boundaries.

What aspects can be creative, what aspects must be observed to ensure a good building in compliance with all safety criteria, aesthetic criteria and uniqueness. It helps your ideas to be more realistic and practical and helps beginners know where to start with their design.

Supermarket in architectural design principles

Let me give some examples, you have to go to the supermarket, you are confused with many goods there. But you have limits. There are only 3 people in your family, you guys only need food for one day, your budget is \$20. See, you are brainstorming which food fits these needs. Now you have your choices for your food.

Important architectural design principles are those that are constructive, reasoned, well-articulated, tested, and fundamental. When someone breaks an architectural concept, which happens from time to time, there must be a good reason. These opportunities can also be used to review and improve principles

That being said, no matter how much you follow the fundamentals of the foundation, the main goal is just to build a building that is visually beautiful, sustainable, and functional.

What are the principles of architectural design?

In fact, a good architect is someone who knows how to change the rules. But you should study these principles carefully to know when and where to break them. Breaking the rules is risky but creative. Sometimes it can lead to new solutions to problems and create a piece that doesn't work for the customer's situation.

These buildings are often not created for living purposes. This is for other purposes like display etc. Regenera, a design by Alberto Ronselli, an Italian architect, is a typical example. This plan was created to restore the ecosystem and help the forest burned by the fire.

Spending time creating, recording, and communicating architectural ideas can help theory and practice align—one of the most important reasons architects need to know the fundamentals of architectural design.

Those principles are like theory and the creativity of every architect is in practice. How do you use them in your work?

How do they bend them to create a unique architecture? It depends on the ability of each architect. But at least with those basic

principles of architectural design, architects can build a building with essential functions: safety, sustainability.

Seven architectural design principles that every architect should know.

Creativity is the signature when mentioning architectural design. They have to deal with creative aspects. But there are common architectural design principles that make the most of the building. To be honest, some architects don't use all of them when creating a piece of architecture.

It includes seven interesting design principles.

- Emphasis
- the balance
- Movement
- Rhythm
- Conflict
- Unity
- Proportion and scale

Balance - one of the first principles of architectural design:

Balance is the art of mixing all categories of visual weights, colors, textures and objects to create a sense of stability, parts of the design are evenly dispersed.

A few tips for using the principles of balance:

- Always remember that every element you place on a page has a certain weight.
- Color, size and texture can all contribute to weight. You can't stick all your heavy elements in one part of your composition, just like you don't put all your furniture in one corner of the

house. If there is no balance, your audience will feel like their eyes are going off the page.

There is also physical and visual balance. It is divided into 5 types:

- Symmetrical or formal balance: In the case of a central line or axis, all elements in the design are the same. Equally weighted pieces on either side of the center line create balance in the symmetrical design.
- Asymmetrical or informal balance: Overall the design is not really the same, but it is intuitive in terms of weight.

Asymmetrical balance – principles of good architectural design

- Radial balance: from the center, design elements radiate outward.

Radial balance - principles of good architectural design

- Vertical balance: the top and bottom parts are both the same size.

Vertical balance - principles of good architectural design

- Horizontal balance: Both left and right sides have equal parts.

Rhythm - the second principles of architectural design

In terms of the use of line, shape, color, texture or pattern, they are rhythm.

Types of rhythm

- Regular rhythm: we repeat each element in a repetition and interval.

Regular balance of architectural design principles

- Random rhythm: We create elements randomly or at irregular intervals

- Graded rhythm: except for one aspect that gradually increases or decreases with each repetition, the repeating element is the same.

Emphasis - the third principles of architectural design

A focal point is an aspect of a design that draws the eye to it.

Emphasis is one of the principles of architectural design.

Size, placement, shape, color and use of lines can all be used to emphasize something.

Proportion and scale - the fourth principles of architectural design

In terms of scale, the relationships between elements in a design are compared.

Golden Mean - Principles of Architectural Design

The golden mean ratio is 3:5.

Visual movement - the fourth principle of architectural design

When a person looks at architecture, whether it is the exterior or the interior of a building, there is a certain movement pattern that catches his eye.

Legendary architecture is a building whose visual movement is clear and people who look at it know where the emphasized parts are.

If architects can master the rest of the principles of architectural design, this main-image movement will emerge.

Contrast - the fifth principle of architectural design

The key here is to make it significantly different. It would be boring for a building without contrast. So make some contrasts to make it more attractive.

Contradiction - the sixth principles of architectural design

For example, black contrasts strongly with white

Not only colors, but you can also contrast with proportion and scale or shape.

Unity - the seventh principles of architectural design

Unity is achieved through consistent use of lines, colors, materials and textures in a design. In terms of texture, it is one of the principles of architectural design that distinguishes a design.

A good building should not only have a good visual beauty but also a good contact experience. Emphasizing texture (make it rough or smooth) will also help your architecture become less dull and boring.

I have listed the basic principles of architectural design. However, no matter how many foundational principles you follow, the key is that they work together to create a beautiful look and optimize the user experience. Architecture should be practical, usable and enjoyable.

Some principles of special architectural design from the famous architecture of the world

As mentioned, architects do not always follow the basic principles of architectural design. This is when the creativity of each architect emerges and makes their work unique

Uniqueness is one of the special principles of architectural design

In terms of attention-grabbing, the iconic building – the Sydney Opera House is a typical example – is the true logo of the city.



Sydney Opera House - What are the basic principles of architecture?

The story of this design is also interesting. A long time ago, the Sydney government decided to build an opera house. This is the desire of every top architecture company. An unknown architect, Jorn Utzon distinguished himself with his unique and pleasing design. After defeating dozens of famous architectural firms, his design was chosen and now it has become one of the world's masterpieces.

- Build an architecture that does not harm the surrounding environment.

This is a simple architectural design principle. Architecture always enters an existing context and thus affects that environment, for example through energy consumption. These concerns have been prioritized by some of the best architects of the last century.



Falling water - what are the principles of architecture?

Frank Wright's design, Falling Water, is one of the small houses with an iconic architectural design, above a waterfall and built on a hillside in a rustic style.

A combination of modern and past - old and new - one of the distinguishing principles of architectural design:

Anyone who has worked in branding will be familiar with the challenge of creating something new while maintaining continuity or even coexistence with an existing system. This challenge may take on a literal meaning in making.



Hearst Tower - What are the principles of architecture?

Want to build a skyscraper in the city center and preserve the beautiful and historic facade of your former building, architecture firm Foster & Partners kept the old buildings of Hearst Tower and built a shiny new building in the middle of the former buildings.



Seagram building in the principles of architectural design.

The Seagram Building in Manhattan, using architectural design principles designed by Ludwig Mies van der Rohe and completed in 1958, is an example of the so-called International Style. Marcel Breuer's brutal cube for the Whitney Museum of American Art, just 20 blocks uptown, has proudly pissed off its posh Madison Avenue neighbors for 50 years (though the museum will move into a new home with many more windows next year.

What is architecture?

The techniques and art of arranging buildings and constructing buildings is architecture. Design and decoration, selection of furniture, supervision of construction and renovation or renovation of the building. Architecture is an art. In addition to design and construction, architecture also deals with aesthetics.

Every human-made building, from the first building to the great skyscrapers of today, is a part of architecture. Architecture is not just art. It is a combination of science and art.

Why do we need design principles in architecture?

Design principles or elements are very important to understanding optical setups. Not only the exterior, but also the interior design plays a significant role in architecture.

Among the initiation of creativity and appreciation of art in its many forms, the principles of design serve very important purposes. To make something more useful and practical.

There is a process on the art board that is intertwined to create a good design. However, there is much more to creating a good design. The design principle in architecture ensures that the construction is useful and that the end product is well built and ready to use.

Principles of architecture

Good design is the result of experience. It takes a lot of experience to make something that has a great design, looks great, and increases the usefulness of something. Everything that is made must be used. Sometimes it is difficult to use a device or anything else that is largely required to perform many tasks in our daily life because of its absurd design. And also poorly designed devices or projects make it look bad.

Experience is needed to achieve good results. It takes a lot of trial, error, and knowledge to create something great. To gain expertise, one must learn from his mistakes. However, in order to make good designs, there is something else that needs to be considered. These things or rules are known to us as principles of architecture.

Talking about the number of principles of architecture, it is said that there are more or less a dozen central principles of architecture. But besides the main principles of architecture, there are other principles as well. These are known to us as the secondary principles of architecture. Some experts consider some of these other secondary principles inferior to the basic and central principles of architecture, but some experts pay good attention to these secondary principles in the field of architecture.

So it's really hard to say how many basic principles or basic principles there are about architecture. However, even if the secondary principles can be ignored, a professional architect should always pay close attention to the primary architectural principles given below.

HSE

The Health and Safety Executive (HSE) is a UK government agency responsible for promoting, regulating and enforcing workplace health, safety and well-being and investigating occupational hazards in Great Britain. It is a non-departmental public body in the United Kingdom, headquartered in Bothell, England. In Northern Ireland, these functions are the responsibility

of the Health and Safety Executive of Northern Ireland. The HSE was established by the Health and Safety at Work Act 1974 and has

since absorbed previous regulatory bodies such as the Factory Inspectorate and the Railway Inspectorate, although the Railway Inspectorate was transferred to the Office of Rail and Road in April 2006. Sponsored by the Department for Work and Pensions. As part of its work, the HSE investigates industrial accidents, both small and large, including major incidents such as the Banskfield explosion and fire in 2005. Although previously reported to the Health and Safety Commission, on 1 April 2008, the two bodies merged.

Function

The duties of the executive director are:

- Helping and encouraging people related to matters related to the performance of health and safety objectives in the workplace, etc. Act of 1974.
- Provide and encourage the necessary arrangements for research and publication, training and information related to their work.
- To ensure the security of government departments, employers, employees, their respective representative organizations and other persons provide advisory and information services and are informed and adequately advised about these matters.
- Establish health and safety regulations.

The executive branch is also required to keep the Secretary of State informed of its plans, ensure alignment with the Secretary of State's policies, and carry out any orders given to it. The Secretary of State can issue orders to the executive branch.

Rail inspection was transferred to the HSE in 1990. On 1 April 2006, the Executive Management lost responsibility for railway safety when the Railway Inspectorate was transferred to the Office of Railway Regulation (now the Office of Rail and Railways).

The executive is responsible for the recruitment medical consulting service that operates as part of its field operations management.

Structure and responsibilities

Local authorities are responsible for enforcing health and safety rules in shops, offices and other areas of the service sector.

Agencies owned by HSE

Executive Director of Health and Safety, Science Department:

Based in Buxton, Derbyshire, the Health & Safety Laboratory (HSL) employs over 350 people including scientists, engineers, psychologists, social scientists, health professionals and technical specialists.

It was established in 1921 under the Safety in Mines Research Board to carry out large-scale experiments related to mining hazards. Following the formation of the HSE, in 1975 the facility became the Safety Engineering Laboratory and the Explosion and Flame Research Laboratory, operating as part of the HSE Research Laboratories Services Division. In 1995 HSL was formed, including the Buxton site and laboratories in Sheffield. In 2004 the Sheffield operations moved to Buxton and the University of Sheffield took over the Sheffield Laboratory site.

It now acts as an agency that carries out research and scientific investigations (eg into the Bansfield fire) for the HSE, other government agencies and the private sector.

HM Inspection of Mines

HM Inspectorate of Mines is responsible for the correct implementation and inspection of safe working practices in all UK mines. Based in Sheffield, South Yorkshire.

The Offshore Safety Division (OSD) was established as a department within the HSE in April 1991. This was in response to Cullen's recommendations regarding the Piper Alpha disaster on 6 July 1988. At the time of the disaster, the Department of Energy (Den) was responsible for offshore production and safety. This was seen as involving a conflict of interest. Dr Tony Barrell, Director of

the HSE's Technology and Air Pollution Division, was appointed OSD Executive Director, having previously been appointed to the

DEn, to lead the transfer of responsibilities. At the same time, Ministerial oversight transferred from the DEn to the Ministry of Employment. The Offshore Safety Act 1992 created the Mining Labor (Offshore Installations) Act 1971 and its subsidiary regulations, statutory provisions relating to health and safety at work, etc., 1974. Responsibility OSD's initial initiatives included the creation of safety regulations, a thorough review of existing safety legislation and a move towards a target-setting regulatory regime. In 1999, OSD became part of the HSE's new Hazardous Installations Directorate. In 2013, it became part of the new Energy Department.

OSHCR (Registration of Occupational Safety and Health Consultants)

The HSE currently operates the Occupational Health and Safety Consultants Register (OSHCR), which is a central register of registered safety consultants in the UK. The aim of the HSE is to devolve responsibility for the operation of the register to the relevant trade and professional bodies once the register is up and running.

Soil examination

The types of soil tests for construction work depend on the characteristics of the soil. The foundation design is based on the soil test report of the construction site. Soil testing for construction of buildings or any structure is the first step in construction planning to understand the suitability of the soil for the proposed construction work. The soil which is responsible for the stress caused by the structure must be well tested to perform well. If the soil is not properly tested, the entire building or structure will suffer or collapse or lean like the Leaning Tower of Pisa. Therefore, soil inspection or testing is the first step to proceed with any construction.

Types of soil testing for building construction

Soil moisture test

Specific gravity test on soil

Dry compaction test in soil

Atterberg's limits test in soil, Proctor compaction test on soil

Various tests are done on the soil to decide the quality of the soil for building construction. Some tests are done in the laboratory and some in the field. Here we discuss the importance of different soil tests for building construction. The soil tests are as follows.

- Moisture level test
- Soil specific gravity
- Dry soil density
- Compaction test
- Soil moisture test

The amount of moisture or the amount of water in the soil is an important parameter for building construction. It is determined by several methods and they are:

- Oven drying method
- Calcium carbide method
- Torsional balance method
- Pycnometer method
- Sand bath method
- Radiation method
- Alcohol method

Of all the above methods, drying in the oven is the most common and the most accurate method. In this method, a soil sample is taken, weighed, placed in an oven and dried at a temperature of 110 degrees + 5 degrees Celsius. After 24 hours, the soil is removed and weighed. The difference between these two weights is defined as the weight of water or moisture in the soil.

Specific gravity test on soil

Soil specific gravity is the ratio of the unit weight of soil solids to the weight of water. It is determined by many methods and they are.

- Density bottle method
- Pycnometer method
- Gas jar method
- Contraction limit method
- Measuring flask method

Density bottle method and pycnometer method are simple and common methods. In the pycnometer method, the pycnometer is weighed in 4 different modes: empty (M1), empty + dry soil (M2), empty + water + dry soil (M3) and filled with water (M4) at room temperature. From these 4 masses, the specific gravity is determined by the following formula.

Dry compaction test in soil

The weight of soil particles in a certain volume of the sample is called the dry density of the soil. The dry density of the soil depends on the proportion of void space and the specific weight of the soil. Based on the dry density values, the soil is divided into dense, moderately dense and loose categories.

The dry density of the soil is calculated by the core cutter method, the sand replacement method and the water displacement method.

Core cutting method for soil dry density test

In this method, a cylindrical core cutter with standard dimensions is used to cut the soil in the ground and lift the cutter with the soil sample. The removed sample is weighed and recorded. Finally, the amount of water for that sample is determined and the dry density is calculated from the following equation.

Sand replacement method for soil dry density test

In this method, a hole is created in the ground by digging the soil, and its dry density is found. The hole is filled with uniform sand of known dry density. Therefore, the volume of the hole is obtained by dividing the mass of sand poured into the hole by the dry density of the sand. Therefore, we can calculate the dry density of the soil from the above formula.

Testing Atterberg's limits in soil

To measure the critical water content of a fine-grained soil, Atterberg proposed 3 limits that represent the properties of fine-grained soil under different conditions. The limits are liquid limit, plastic limit and shrinkage limit. These limits are calculated by individual tests as follows.

Liquid limit test in soil

In this experiment, the Casagrande liquid restriction device was used, which consists of a cup with an up and down movement mechanism. The cup is filled with the soil sample and a groove is created in the middle of the cup with a suitable tool. When the cup moves up and down with the help of the handle, the groove closes at a point.

Note the number of strokes required to close the groove. After that, the water content of the soil is determined. Repeat this procedure 3 times and draw a graph between $\log N$ and soil water content. The water content of $N=25$ is the liquid limit of the soil.

Plastic limitation test in soil

Take a sample of soil and add some water to make it plastic enough to form a small ball. Let it rest for a while and then put the ball in a glass plate and roll it into threads with a diameter of 3 mm.

If the threads do not break when we twist it to a diameter of less than 3 mm, the water content is higher than the plastic limit. In this case, reduce the amount of water and repeat the same procedure

until it is crushed in a diameter of 3 mm. Finally, find out the water content of the resulting soil, which is nothing but the plastic limit.

Shrinkage limit test in soil

In the case of shrinkage limitation, the amount of water in the soil is sufficient to fill the empty space of the soil. That is, the degree of saturation is 100 percent. Therefore, if we reduce the shrinkage limit, there will be no change in the volume of the soil. It is determined by the following formula for the specified soil sample.

Proctor compaction test on soil

The Proctor test is used to determine the compaction characteristics of the soil. Soil compaction is nothing but the reduction of air voids in the soil by compaction. The degree of compaction is measured by the dry density of the soil.

In the Proctor compaction test, the given soil sample was sieved through 20 mm and 4.75 mm sieves. The percentage passing through 4.75 mm and the remaining percentage at 4.75 mm are mixed in specific proportions.

Add water to it and leave it in a closed container for 20 hours. Mix the soil and divide it into 6 to 8 parts. Put the mold in place and pour a part of the soil into the mold in 3 layers and pound 25 times for each layer.

Remove the base plate and weigh the soil along with the mold. Remove the soil from the mold and take a small part of the soil in different layers and test the water content. From the values, find the dry density of soil and water content and draw a graph between them and note the maximum dry density and optimum water content of the compacted soil sample at the highest point of the curve.

What is the dry density of soil?

The weight of soil particles in a certain volume of the sample is called the dry density of the soil. The dry density of the soil depends on the proportion of void space and the specific weight of the soil. Based on the dry density values, the soil is divided into dense, moderately dense and loose categories.

The dry density of the soil is calculated by the core cutter method, the sand replacement method and the water displacement method.

How to determine soil moisture?

The amount of moisture or the amount of water in the soil is an important parameter for building construction. It is determined by several methods and they are:

- Oven drying method
- Calcium carbide method
- Torsional balance method
- Pycnometer method
- Sand bath method
- Radiation method
- Alcohol method

Of all the above methods, drying in the oven is the most common and the most accurate method. In this method, a soil sample is taken, weighed, placed in an oven and dried at a temperature of 110 ± 5 degrees Celsius. After 24 hours, the soil is removed and weighed. The difference between these two weights is defined as the weight of water or moisture in the soil.

What are the different tests to check the quality of concrete?

Qualitative tests are performed on concrete as part of quality control of concrete structures. Various qualitative tests on concrete such as compressive strength tests, slump tests, permeability tests etc. are used to ensure the quality of concrete provided for a particular specification.

These qualitative tests on concrete give an idea about concrete properties such as strength, durability, air content, permeability, etc.

Tests to check the quality of concrete

Each quality test performed on concrete determines the quality result of the corresponding concrete. Therefore, it is not possible to perform all tests to determine the quality of concrete. We have to

choose the best tests that can give a good judgment about the quality of concrete.

The initial quality test determines the variation of concrete characteristics from the required and standard concrete characteristics. Quality tests ensure that the best quality of concrete is placed in place to produce concrete structural members with the desired strength.

Below are the qualitative tests performed on fresh and hardened concrete.

Tests to check the quality of concrete

Quality test on fresh concrete

1. Performance tests
2. Air content
3. Setting the time

Testing on hardened concrete

- pushing resistance
- Tensile strength
- Modulus of elasticity
- Permeability tests on concrete
- In situ testing on concrete
- Compression test and drop test for quality tests

Tests to check the quality of concrete

Each quality test performed on concrete determines the quality result of the corresponding concrete. Therefore, it is not possible to perform all tests to determine the quality of concrete. We have to choose the best tests that can give a good judgment about the quality of concrete.

The initial quality test determines the variation of concrete characteristics from the required and standard concrete

characteristics. Quality tests ensure that the best quality of concrete is placed in place to produce concrete structural members with the desired strength.

Below are the qualitative tests performed on fresh and hardened concrete.

Quality test on fresh concrete

The most common quality tests on fresh concrete are:

1. Performance tests

Concrete mix efficiency is measured by Vee-bee constometer test, compaction coefficient test and slump test.

2. Air content

Air content measures the total air content in the fresh concrete sample, but does not represent the final in-place air content, as a certain amount of air is lost in transportation, consolidation, placing and finishing.

3. Setting the time

The act of changing the mixed cement from liquid to solid state is called "cement setting".

Initial setting time is defined as the period elapsed between the time when water is added to the cement and the time when the 1 mm square needle does not pierce the test block to a depth of about 5 mm from the bottom of the mold.

The final setting time is defined as the period elapsed between the time when water is added to the cement and when the needle of a 1 mm square cross-section with a 5 mm diameter joint impacts the test block.

Other tests performed on fresh concrete include:

- Resistance to segregation
- Weight

- Wet analysis

- Temperatures
- Heat production
- Bleeding

Testing on hardened concrete

The most common quality tests on hardened concrete are:

1. Compressive strength

Concrete cube compressive strength test gives an idea about all the properties of concrete.

2. Tensile strength

Tensile strength of concrete is one of the basic and important characteristics that has a significant effect on the amount and size of structural cracking. In addition, concrete is very weak in tension due to its brittle nature. therefore. It is not expected to withstand direct tension. Therefore, concrete cracks when tensile forces exceed its tensile strength. Therefore, it is necessary to determine the tensile strength of concrete to determine the load at which concrete members may crack.

3. Modulus of elasticity

The modulus of elasticity of concrete is the ratio of stress to strain of concrete under load.

4. Permeability tests on concrete

When concrete is permeable, it can cause corrosion in the reinforcements in the presence of oxygen, moisture, CO₂, SO₃- and Cl-, etc. This rust formation due to corrosion is approximately 6 times the volume of the steel oxide layer, which results in cracking. It develops in reinforced concrete and starts to spall the concrete.

5. In site test on concrete

Various in-situ tests are performed on hardened concrete, both destructive and non-destructive. Some of them are concrete yield tests, fracture tests, Schmidt-hammer test.

Other quality tests are performed to test the following:

- Modulus of rupture
- Density
- Contraction
- Shrinkage
- Freeze/thaw resistance
- Resistance to aggressive chemicals
- abrasion resistance
- Link to boost
- Absorption

Compression test and drop test for quality tests

Among the tests mentioned above, the two main tests that are mainly considered as quality tests are compression tests and slump tests. If necessary, tests are performed to determine the temperature of fresh concrete and the density of hardened concrete.

The reasons for choosing compressive strength test and slump test in practice for concrete quality control test are:

Most of the properties of concrete are related to compressive strength, which is obtained by compressive strength test.

Compressive strength test is the simplest, most economical or most accurate test.

The variability of concrete is best studied using compressive strength tests.

The quality of the mixture is judged by the slump test. It examines the diversity of construction materials in the mix. These tests focus on the water-cement ratio of the concrete mix.

Drop testing is easy to do. It determines the quality of concrete very quickly before placing. The placement standards are recommended according to the relevant concrete codes of practice.

Slump testing is performed on-site, which does not require laboratory setup or expensive testing machines. Hence, this test is cost-effective.

Before pouring into the mold, we perform the slump test. Therefore, if there is a problem with the quality of the concrete, the tested batch can be rejected. This helps to raise a faulty structural member and prevent future dismantling and repair.

welding test

Weld testing is an important step in ensuring weld quality. There are different types of welding tests, each with its own purpose and testing requirements. Some common welding tests are visual inspection, bend test, tensile test, visual inspection and radiographic test.

Welders must be able to produce high-quality welds that meet customer-specified or code requirements (eg, AWS D1. 1/ ASME Section IX).

Welds must be tested to ensure they meet these requirements. Weld testing is a method of evaluating weld quality and identifying any defects that may be present.

There are different types of welding tests (destructive tests and non-destructive tests) that are described in this post, each with its own purposes.

Some of the common welding tests are bend test, tensile test, visual inspection, penetration test and radiographic test. Each of these tests has its own advantages and disadvantages.

Why do we need a welding test?

Welding is an important process in manufacturing and construction. It is used to connect two or more metal pieces together. Welding is a special process (according to ISO 9001) that ensures that the welder is able to do the job correctly.

This is why we need to test the weld. The welding test evaluates the skills and abilities of the welder.

It also helps ensure the safety of the welder and the people around him. Welding test is necessary to ensure welding quality and prevent accidents.

Another purpose of weld testing is to ensure that welds meet the mechanical and technological property requirements for their intended use.

For this, cut samples of the weld joint are subjected to various tests (such as bending test, corrosion test, hardness test or RT) to confirm and ensure the integrity of the weld.

Welding test methods

Welding test methods are essential to ensure welding quality. There are different methods of weld testing, each of which has its own advantages and disadvantages.

Welding test methods can be classified into two main types:

Destructive testing - break test, bend test, macro test, tensile test, etc.

Non-destructive testing - visual testing, penetration testing, radiographic testing, etc.

The most common weld testing methods are manual visual inspection, radiography, ultrasonic testing, magnetic particle inspection, and liquid penetrant inspection.

What is destructive testing?

Destructive testing is a type of testing that involves the intentional destruction of a weld to test the weld.

Destructive testing is used to evaluate the strength, health and reliability of a welded joint. There are several types of destructive testing, including:

- tensile test
- Fracture toughness test
- Impact test
- Bending test
- Macro test
- Hardness test
- Nice failure test
- Fracture testing etc. to name a few types

All these destructive tests are used to evaluate the strength and reliability of welds by subjecting them to a weld test. Welds are usually subjected to mechanical loading to see how they respond.

NDT is another type of welding testing method used to assess the health, integrity and reliability of parts. NDT stands for Non-Destructive Testing. NDT involves inspecting parts without damaging them.

Non-Destructive Testing

As the world strives to become more environmentally friendly, non-destructive testing (NDT) has become an important part of many industries.

NDT allows products and parts to be inspected without causing damage, meaning they can be reused or recycled.

There are a variety of NDT techniques, each with its own strengths and weaknesses. Some of the most common techniques are:

- visual inspection
- Penetration testing

- Ultrasound test

- Radiographic test
- Inspection of magnetic particles
- Eddy current test
- Magnetic flux leakage test

Leak test

Welding is a process that can create some of the strongest bonds in metalworking. However, welding can also cause defects in the weld joint that may weaken the structure.

Non-destructive testing (NDT) allows welders to identify these defects and fix them before they become a problem. NDT can also be used to inspect welds for quality control purposes.

Types of destructive tests for weld testing

Destructive testing is a type of testing used to determine weld quality. There are many different types of destructive tests, but some of the most common are fracture mechanics testing, impact testing, and hardness testing.

Fracture mechanics testing is used to determine weld strength. Impact testing is used to see how well a weld can withstand impact loading. And the hardness test is used to measure the hardness of the weld.

1. Moment test for welding test

Bend testing is a common weld inspection method used to verify weld quality. The bend test is performed by bending the welded part around a specified notch or radius.

The weld must not fail and the metal must not crack under stress during bending in order for the result of the bending test to be acceptable.

Tensile test for welding test

Welding is the process of joining two or more pieces of metal by heating the pieces to their boiling temperature and then contacting them with each other.

The welded joint must have the same strength as the base metal. A tensile test should be performed on the welded joint to ensure that the welded joint has the same strength as the base metal.

Tensile test method, types of equipment and laboratory report

Tensile testing is performed by pulling the welded joint until it breaks under tension. The amount of force required to separate the welded joint is called breaking strength or ultimate strength. Breaking strength is measured in pounds per square inch (psi) or megapascals (MPa) or N/mm².

Tensile testing can be done in two ways for welding testing:

Transverse tensile test and

Longitudinal tensile test (all weld tensile tests).

Macro welding test for welding test

Macro weld test is a test to measure weld quality by observing weld penetration, weld area, HAZ and its microstructure against the presence of welding discontinuities. This test is performed by etching and polishing the weld to reveal its microstructure.

Weld quality can be determined from microstructure, such as grain size and shape, the presence of defects, and the degree of separation between grains is monitored and reported.

Impact test for welding test

The Charpy impact test is a welding test used to determine the toughness of a welded joint. This test is performed by striking the weld with a falling pendulum and measuring the amount of energy required to break the weld.

The energy required to cause failure is called the "Charpy V-notch" toughness or energy.

The Charpy impact test is used to determine the toughness of a welded joint and to compare the toughness of different welding processes.

Test for weld

This test is applied to a butt-welded joint in a plate or tube to check the health of the weld. Typical sample dimensions for plate and tube.

No need to remove the welding armature. The specimen is braced as shown in the figure below and ruptured by giving one or more sudden sharp blows with a hammer at the point of the groove or notch as shown.

The speed of force application is not critical, as it does not affect the appearance of the fractured surface.

The fracture surface is checked for internal defects, such as lack of fusion, slag inclusions, and porosity.

This test can be easily performed in shops and sites to quickly assess weld quality, as no sophisticated equipment is required and interpretation is relatively simple.

Free moment test for welding test

The free bend test measures the ductility of the weld metal in a butt joint in a plate or tube in terms of percentage elongation.

The thickness of the sample is the same as the plate or tube, its width is 1.5 times the thickness and its length is between 150 mm for 6 mm ton and 450 mm for 50 mm ton. Length is not mandatory.

Moment test in welding and types of bending test

The weld is covered up to the surface of the plate by filing, grinding or machining, taking into account that the tool marks must be along the length of the specimen.

It is important that the line between the weld metal and the base metal is clearly visible, and if necessary, the sample surface is etched with a suitable reagent.

Two gauge lines are lightly marked on the sample. The distance between the gauge lines should be 3 mm less than the width of the weld.

Fillet-weld-fracture test for weld test

This test is similar to the break break test and is for welding health test. The test specimen, as shown in the figure below, consists of two plates forming a tee joint and a fillet weld placed on the outer side of the joint.

The parameters of the base metal, weld metal and welding must be accurate according to the conditions specified in the welding method.

Sticky welds at the ends of the joints should be avoided as they make it difficult to tear the specimen. The placement of the sample and the direction of the force are also shown in the figure above.

Forces may be applied using a testing machine, press or hammer blows. Broken surfaces are checked for internal defects such as porosity, incomplete root penetration and slag inclusions.

Toughness test for welding test

The term metal toughness cannot be precisely defined and has many meanings. In general, toughness usually means resistance to deformation, and in the case of metals, it is a measure of their resistance to plastic or permanent deformation.

If the metal has more toughness, it resistant more against scratches, wear, penetration, machining and mechanical cutting.

Tensile strength also increases with toughness. The hardness of the base metal and weld metal of a welded joint is influenced by the chemical composition, metallurgical effects of welding, cold working of the metal, heat treatment and several other factors.

Limits must be applied to the toughness of the heat-affected zone and weld metal, because if they are too hard, they will not have

sufficient ductility for service conditions, and their corrosion resistance may be impaired.

There are nearly 30 methods for hardness testing or toughness measurement, but the most commonly used are:

Brinell toughness

Vickers toughness

Rockwell toughness

Hardness test for welding test

The term metal hardness cannot be precisely defined and has many meanings. In general, hardness usually means resistance to deformation, and in the case of metals, it is a measure of their resistance to plastic or permanent deformation.

The harder the metal, the more resistant it is to scratches, wear, penetration, machining and mechanical cutting.

Tensile strength also increases with hardness. The hardness of the base metal and weld metal of a welded joint is influenced by the chemical composition, metallurgical effects of welding, cold working of the metal, heat treatment and several other factors.

Limits must be applied to the hardness of the heat-affected zone and weld metal, because if they are too hard, they will not have sufficient ductility for service conditions, and their corrosion resistance may be impaired.

There are nearly 30 methods for hardness testing or hardness measurement, but the most commonly used are:

Brinell hardness

Vickers hardness

Rockwell hardness

Weight loss test for welding test

This test is designed to measure the fracture initiation characteristics of structural materials heavier than 18mm.

The dimensions of the sample are different according to the thickness of the plate. For 25.4 mm ton, the length and width are

355 and 90 mm. For 19 mm ton, the corresponding dimensions are 127 and 51 mm. A weld bead 63.5 mm long and 12.5 mm wide is placed on the tensile surface of the specimen using a special hard electrode.

It is fixed with punch marks at A, B and C. In fact, two nuts are placed, one from A to C and the other from B to C as shown in the figure, so that the end openings meet at point C.

The weld bead, which is a brittle material, is called a crack-starter weld. A cut is made in the center of the length of the bead and is placed at a right angle to the weld bead and parallel to the sample.

The sample is mounted on an anvil equipped with a stop block. The impact load is applied by reducing the weight. The design of the machine proposed by ASTM allows the use of different weights and different drop heights according to the resistance level of the metal.

Non-destructive testing (NDT) for weld testing

Non-destructive testing, or NDT, is a process for inspecting and evaluating a weld without causing damage. There are several types of NDT, but the most common are visual inspection, radiographic, ultrasonic, and magnetic particle testing.

Visual inspection is simply looking at the weld to see if it meets the requirements. Radiography uses X-rays to image the weld and check for any defects.

Ultrasonic uses sound waves to detect discontinuities in welds. Magnetic particle testing uses a magnetic field and iron particles to detect cracks and other defects.

All these methods have their own advantages and disadvantages. For example, radiography can detect very small defects, but it can be expensive and time-consuming. Ultrasound is relatively cheap and fast, but can only detect discontinuities that are of a certain size or larger.

1. Penetration test (PT)

Liquid Penetrant Testing (DP Test) is a non-destructive testing (NDT) method that uses a liquid penetrant to detect discontinuities in welds.

The penetrant enters the weld by capillary action and is drawn out by the action of an expander.

Any discontinuity in the weld allows the penetrant to penetrate and be pulled out by the fabricator, causing a visible mark on the weld surface.

Liquid penetration test (DP test)

There are two types of penetrants: water-soluble and solvent-based.

Water-soluble penetrants are less aggressive than solvent-based penetrants and are less likely to damage the weld. However, solvent-based penetrants are more aggressive and can cause weld damage if not removed properly.

2. Magnetic particle test (MT or MPI)

Magnetic particle testing (MPT) or magnetic particle inspection (MPI) is a type of non-destructive testing (NDT) used to inspect and determine surface and subsurface defects in ferromagnetic materials.

The principle behind this technique is that a magnetic field causes magnetic particles to gather around discontinuities in the material.

M PT can be used to detect cracks, seams, laps, voids and other defects in ferromagnetic materials.

Principle, techniques, types, advantages, limitations and standards of magnetic particle (MT) testing.

The most common application of MPT is in the welding industry. Welders use MPT to check welds for defects before releasing them for use. MPT is also used to inspect welds that have been repaired.

Hardness test for welding test

The term metal hardness cannot be precisely defined and has many meanings. In general, hardness usually means resistance to deformation, and in the case of metals, it is a measure of their resistance to plastic or permanent deformation.

The harder the metal, the more resistant it is to scratches, wear, penetration, machining and mechanical cutting.

Tensile strength also increases with hardness. The hardness of the base metal and weld metal of a welded joint is influenced by the chemical composition, metallurgical effects of welding, cold working of the metal, heat treatment and several other factors.

Limits must be applied to the hardness of the heat-affected zone and weld metal, because if they are too hard, they will not have sufficient ductility for service conditions, and their corrosion resistance may be impaired.

There are nearly 30 methods for hardness testing or hardness measurement, but the most commonly used are:

Brinell hardness

Vickers hardness

Rockwell hardness

Weight loss test for welding test

This test is designed to measure the fracture initiation characteristics of structural materials heavier than 18mm.

The dimensions of the sample are different according to the thickness of the plate. For 25.4 mm ton, the length and width are 355 and 90 mm. For 19 mm ton, the corresponding dimensions are 127 and 51 mm. A weld bead 63.5 mm long and 12.5 mm wide is placed on the tensile surface of the specimen using a special hard electrode.

It is fixed with punch marks at A, B and C. In fact, two nuts are placed, one from A to C and the other from B to C as shown in the figure, so that the end openings meet at point C.

The weld bead, which is a brittle material, is called a crack-starter weld. A cut is made in the center of the length of the bead and is placed at a right angle to the weld bead and parallel to the sample.

The sample is mounted on an anvil equipped with a stop block. The impact load is applied by reducing the weight. The design of the machine proposed by ASTM allows the use of different weights and different drop heights according to the resistance level of the metal.

Non-destructive testing (NDT) for weld testing

Non-destructive testing, or NDT, is a process for inspecting and evaluating a weld without causing damage. There are several types of NDT, but the most common are visual inspection, radiographic, ultrasonic, and magnetic particle testing.

Visual inspection is simply looking at the weld to see if it meets the requirements. Radiography uses X-rays to image the weld and check for any defects.

Ultrasonic uses sound waves to detect discontinuities in welds. Magnetic particle testing uses a magnetic field and iron particles to detect cracks and other defects.

All these methods have their own advantages and disadvantages. For example, radiography can detect very small defects, but it can be expensive and time-consuming. Ultrasound is relatively cheap and fast, but can only detect discontinuities that are of a certain size or larger.

1. Penetration test (PT)

Liquid Penetration Testing (DP Test) is a non-destructive testing (NDT) method that uses a liquid penetrant to detect discontinuities in welds.

The penetrant enters the weld by capillary action and is drawn out by the action of an expander.

Any discontinuity in the weld allows the penetrant to penetrate and be pulled out by the fabricator, causing a visible mark on the weld surface.

Liquid penetration test (DP test)

There are two types of penetrants: water-soluble and solvent-based.

Water-soluble penetrants are less aggressive than solvent-based penetrants and are less likely to damage the weld. However, solvent-based penetrants are more aggressive and can cause weld damage if not removed properly.

2. Magnetic particle test (MT or MPI)

Magnetic particle testing (MPT) or magnetic particle inspection (MPI) is a type of non-destructive testing (NDT) used to inspect and determine surface and subsurface defects in ferromagnetic materials.

The principle behind this technique is that a magnetic field causes magnetic particles to gather around discontinuities in the material.

MPT can be used to detect cracks, seams, laps, voids and other defects in ferromagnetic materials.

Principle, techniques, types, advantages, limitations and standards of magnetic particle (MT) testing.

The most common application of MPT is in the welding industry. Welders use MPT to check welds for defects before releasing them for use. MPT is also used to inspect welds that have been repaired.

3. Ultrasonic test (UT)

Ultrasonic testing (UT) is a non-destructive testing (NDT) method that uses sound waves to examine the internal structure of a material. UT can be used to detect discontinuities, such as cracks or porosity, in welds and base materials.

There are two main types of ultrasonic testing:

Pulse echo and transmission

In the pulse echo test, a wave of sound waves is sent into the material and the reflected waves are detected by the receiver.

The time between sending the burst and receiving the reflected waves can be used to calculate the distance to the discontinuity.

In the transmission test, a probe is inserted into the material and ultrasound is transmitted through it. The reflected ultrasound is then detected by another probe on the other side of the material.

4. Radiographic test (RT)

Radiographic testing, also known as RT or X-ray, is a common method of inspecting welds for defects.

A radiograph is an image of a boil that is created by radiation passing through the boil and hitting a layer on the other side. By viewing the image profile on the film, inspectors can identify any defects in the weld.

One of the advantages of radiographic testing is that it can be used to inspect surface and subsurface defects.

In addition, it can be used to inspect both joints and the weld itself. However, radiographic testing is expensive and time-consuming, so it is not always practical to use in every situation.

5. Visual test (VT)

Visual testing is a method of inspecting welds for defects. This technique uses the human eye to inspect welds for discontinuities, lack of fusion, porosity, slag inclusions, and other welding defects.

Visual inspection is often used as the primary inspection method for welds that are not easily accessible or are too large to be tested by other methods.

What is VT?

Visual testing is usually performed by a welder who is qualified as a weld inspector. The inspector inspects the weld visually and looks for any signs of defects.

Observed defects can be repaired before completing the welding process or servicing the part.

6. Electromagnetic eddy current test

Eddy current testing is a non-destructive testing (NDT) that uses the principle of electromagnetics to detect defects in metal objects.

A coil is placed around the test object and an electric current passes through the coil.

This creates a magnetic field that causes currents to flow through the metal object in a circular pattern (eddy currents).

If there is any defect in the metal, it disrupts the flow of these eddy currents and this can be detected by changes in the magnetic field.

Eddy current testing is often used to check weld defects. If there is any doubt about the quality of the weld, the weld itself can be tested or the surrounding area can be tested. This test can be used to detect cracks, porosity, lack of fusion and other defects.

Bolt and nut testing

Mechanical tests related to nuts are:

Hardness measurement of surface and core

Evidence test

The mechanical properties of all types of nuts and bolts are checked according to different standards, the most common of which are:

Standard ISO 898-1 for screws and ISO 898-2 for nuts ASTM

A193 standard for screws and ASTM A194 for nuts Iranian

national standard No. 4555 for bolts and nuts do not rust Iranian

National Standard No. 2874 for double threaded screws Iranian

National Standard No. 5654 for coarse rib nuts

Iranian National Standard No. 5655 for small gear nuts

ASTM F606M and ISO 3506 standards and various DIN standards including 933, 931, 558, 6914, etc.

Tensile test with full section

In this test, the full size screw is placed in the special fixture of the tension device and tested. The tensile test proceeds to the bolt failure stage and the mechanical properties including yield stress, ultimate strength, and elongation are calculated. Then the mechanical properties are matched to the relevant standard. If the screw threads are damaged and do not fail, the test will not be accepted.

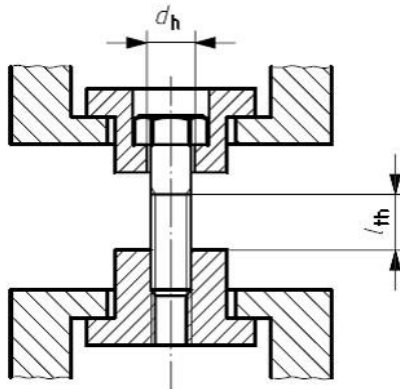

Bolt tension test fixture

Some test conditions in the ISO 898-1 standard:

- The length of the thread involved must be at least $1d$.
- The length of the free threaded part under load must be at least $1d$. In the case of structural bolts with short thread length, the test can be performed with a free thread length of less than $1d$.
- Test speed should not exceed 25 mm/min.
- The test continues until the end of the shaft and the maximum tensile force F_m is determined.

Tensile test of machined sample (dumbbell)

Usually, if it is not possible to test the screw in full cross-section or at the request of the employer, dumbbell samples are prepared by machining and subjected to tensile test. Then the tensile properties are matched to the relevant standard.



Dumbbell machined bolt

The purpose of this test is to determine the following:

- Tensile strength
- Low yield stress or stress in elongation 0.2%
- Elongation percentage after failure
- Percentage reduction of cross-sectional area after failure

The diameter of the machined sample should be $d_0 < d_3$, min, but preferably $d_0 \geq 3$ mm.

When machining samples related to quenched and tempered screws with a nominal diameter $d > 16$ mm, the initial diameter reduction should not be more than 25%. (about 44% of the initial cross section)

Tensile test is performed according to ISO 6892-1 standard. The test speed should not exceed 10mm/min until the yield point and 25mm/min after that.

Wedge Test

This test is similar to the full-section tensile test, except that a wedge-shaped washer with standard dimensions is placed under the screw cap and applies a shear force to the cap during the tensile test. After the test, in addition to meeting the strength of the desired class, no cracks should be observed in the screw cap.

The washer is placed under the screw head according to the figure and the full size sample is tested.

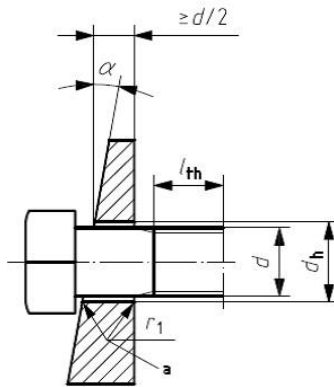

Bolt clamp test fixture

requirements

For bolts with $d_s > d_2$ and full thread, failure must occur in the threaded portion.

In the case of bolts with $d_s \approx d_2$, the failure must occur in the threaded or non-threaded part.

Tensile strength must comply with the minimum value listed in Table 3.

Inspection of the integrity of the clavicle and screw shank

- Failure should not occur in a cage.
- In the case of bolts with non-threaded shanks, failure should not occur in the connection area between the collar and the shank.
- In the case of fully threaded bolts, the failure can extend to the joint area between the lug and the threaded part or even the lug, provided that it originates from the threaded area.

Proof Load Test

The bolt test consists of two main stages as follows:

- Application of a specified tensile load and

Reference Book Of International Building Standards — Chapter Four

- Measurement of the permanent increase in length if it is caused by the proof

The screw must be inserted into the corresponding fixtures as shown. The fully threaded screw is inserted into two threaded fixtures. The length of the threaded part involved must be at least $1d$.

According to the relevant tables, the bar must be axially inserted into the screw.

The test speed should not exceed 3 mm/min. The desired certificate must be applied for 15 seconds.

The nut bar test is also done in a similar way.

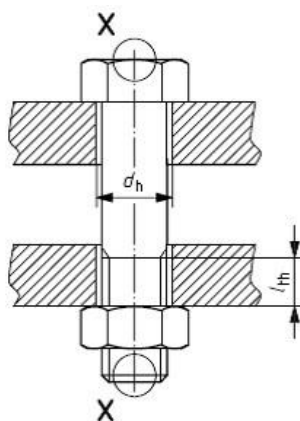

Bolt and nut test fixture

Impact test

The purpose of the impact test is to check the strength of the screw under the impact force at a certain low temperature. This test is performed only in case of compliance with the product standard or agreement between the manufacturer and the buyer.

Machined samples according to ISO 898-1 standard

Machined specimens shall conform to the V-notch Sharpie test in ISO standard 1-148. Samples should be prepared longitudinally and as close as possible to the surface of the bolt and in the threaded part.

Reference Book Of International Building Standards — Chapter Four
The non-notched part of the sample should be close to the surface of the screw.

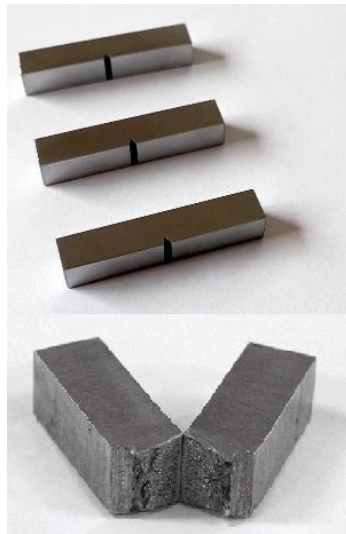

Charpy impact sample machined according to standard

Test steps

Machined samples should be kept at a stable temperature of $-20\text{ }^{\circ}\text{C}$. The impact test shall be performed according to ISO 148-1.

requirements

The impact resistance at $-20\text{ }^{\circ}\text{C}$ must be in accordance with the relevant table.

In addition to the above mechanical tests, there are other tests mentioned in different standards that must be performed for the full compatibility of bolts and nuts.

Testing of concrete and building materials

In this laboratory, experiments related to materials and concrete are conducted, the main focus of which is on undergraduate education. This laboratory is also used for research studies of post-graduate students and on average, about 2 to 6 students make concrete samples in small sizes (cubes, cylinders and small beams) to large (structural elements such as beams) every year. Some of the equipment and tests that can be performed are as follows.

- Los Angeles device to determine the wear percentage of materials
- Electric furnace in different volumes to heat all kinds of materials
- Mixer of concrete and other materials in different volumes
- Concrete cutter machine
- 200 and 300 ton presses to determine the compressive strength of concrete, brick and other materials
- Furnace for drying materials
- Device for determining tensile and bending strength of cement
- 2 kg stone crusher for crushing aggregates in different sizes
- Mechanical sander for granulation of materials
- Vibrating table for vibrating concrete
- Freezer for cooling different materials
- Concrete air measuring device
- Blaine to measure the level of cement
- Silan table to measure the normal concentration of mortar
- Vicat to measure the concentration of normal and cement mortar
- Mill to grind materials in small volume
- Scales with different capacity and accuracy
- Luchatlier flask for measuring the specific weight of cement and materials
- 40 ton press to determine the bending strength of materials
- Device for determining the dynamic resistance of concrete

- 75 liter autoclave for quick concrete processing

- Device for measuring the thermal performance of concrete panels
- The device for determining the stability of concrete during the rapid freezing and thawing cycle

Experiments that can be done

1- Concrete tests

- Designing and manufacturing different concretes and preparing all kinds of standard concrete samples (ordinary concrete, high strength concrete, self-compacting concrete, fiber concrete, roller concrete, etc.) along with maintaining concrete samples in different regimes (temperature, humidity And...)
- Determining the compressive, moment and tensile strengths of concrete
- Determining the modulus of elasticity and Poisson's ratio
- Evaluating the efficiency of self-compacting concrete
- Sampling fresh concrete and conducting quality control tests during the work
- Determination of concrete setting time
- Determination of water absorption of hardened concrete
- Determining the depth of water penetration in concrete
- Determination of concrete resistance against melting and freezing cycles
- Determining the in-situ strength of concrete by non-destructive test of Schmidt's hammer and cement tests
- Determining the percentage of normal concentration and setting time of cement
- Determining the softness and density of cement

- Determination of mental strength of cement mortar

- Determining the compressive and moment strengths of cement mortar
 - Determining the specific weight of cement for stone materials tests
 - Determination of particle size and percentage of particles passing through a 75 micron sieve
 - Determination of specific gravity and water absorption of aggregates
 - Determination of bulk density and empty spaces of aggregates
 - Determining the wear resistance of aggregates by the Los Angeles device
 - Determining the amount of clay lumps and light particles of aggregates
 - Determination of organic impurities of fine-grained materials
 - Determination of flake and needle particles of aggregates
 - Determining the characteristics of light grains
- 2- Tests of other building materials
- Determining the physical properties of bricks
 - Determining the compressive and moment strength of bricks
 - Determining the degree of softness, volumetric weight, normal concentration and setting time of construction plaster
 - Determining the compressive and moment strength of construction plaster

References

Persian resources

- 1 .Components of building and workshop, Siavash Kabari, 1386 edition, page 128
- 2 .Analysis and Design of Reinforced Concrete Structures, Amir Masoud Kaynia, ISBN: 6-08-6122-964-978, Isfahan University of Technology Jihad Publications, 17th edition, page 48, pages 49-52, pages 52-56, pages 58-56.
3. Sotoudeh Bidakhti, Amirhossein, 2013, An introduction to the application of BIM building information modeling in the management of construction projects, the first national conference on urban planning, urban management and sustainable development, Tehran, Iranian Institute, Iranian Architectural Association.

Non-Persian sources

1. "concretus". Latin Lookup. Archived from the original on 12 May 2013. Retrieved 1 October 2012.
2. a b Gromicko, Nick; Shepard, Kenton (2016). "The History of Concrete". International Association of Certified Home Inspectors, Inc. Retrieved 27 December 2018.
3. Moore, David (6 October 2014). "Roman Concrete Research". Romanconcrete. com. Archived from the original on 6 October 2014. Retrieved 13 August 2022.

4. Heinrich Schliemann; Wilhelm Dörpfeld; Felix Adler (1885. Tiryns: The Prehistoric Palace of the Kings of Tiryns, the Results of the Latest Excavations. New York: Charles Scribner's Sons. pp. 190, 203–204, 215.
5. Sparavigna, Amelia Carolina (2011. "Ancient concrete works". arXiv:1110.5230 [physics. pop-ph].
6. Jacobsen T and Lloyd S, (1935 "Sennacherib's Aqueduct at Jerwan," Oriental Institute Publications 24, Chicago University Press
7. Stella L. Marusin (1 January 1996. "Ancient Concrete Structures". Concrete International. 18 (1: 56–58.
8. "The History of Concrete". Dept. of Materials Science and Engineering, University of Illinois, Urbana-Champaign. Archived from the original on 27 November 2012. Retrieved 8 January 2013.
9. « Château de Chazelet » [archive], notice no PA00097319, base Mérimée, ministère français de la Culture.
10. "Concrete: Scientific Principles". matse1. matse. illinois. edu. Retrieved 6 October 2021.
11. a b Askarian, Mahya; Fakhretaha Aval, Siavash; Joshaghani, Alireza (22 January 2019. "A comprehensive experimental study on the performance of pumice powder in self-compacting concrete (SCC)". Journal of Sustainable Cement-Based Materials. 7 (6: 340–356. doi:10.1080/21650373.2018.1511486. S2CID 139554392.
12. Melander, John M. ; Farny, James A. ; Isberner, Albert W. Jr. (2003. "Portland Cement Plaster/Stucco Manual" (PDF. Portland Cement Association. Archived (PDF from the original on 12 April 2021. Retrieved 13 July 2021.
13. Evelien Cochez; Wouter Nijs; Giorgio Simbolotti & Giancarlo Tosato. "Cement Production" (PDF. IEA ETSAP – Energy Technology Systems Analysis Programme. Archived from the original (PDF on 24 January 2013. Retrieved 9 January 2013.
14. Gibbons, Jack. "Measuring Water in Concrete". Concrete Construction. Archived from the original on 11 May 2013. Retrieved 1

October 2012.

15. "Chapter 9: Designing and Proportioning Normal Concrete Mixtures" (PDF. PCA manual. Portland Concrete Association. Archived (PDF from the original on 26 May 2012. Retrieved 1 October 2012.
16. Taha, Ramzi A. ; Al-Harthy, Ali S. ; Al-Jabri, Khalifa S. (2010. "Use of production and brackish water in concrete mixtures" (PDF. International Journal of Sustainable Water and Environmental System. 1 (2: 39–43. doi:10. 5383/swes. 01. 02. 001. S2CID 250602063. Archived (PDF from the original on 9 October 2022.
17. a b "Cement hydration". Understanding Cement. Archived from the original on 17 October 2012. Retrieved 1 October 2012.
18. "Cement Paste – an overview". www. sciencedirect. com | ScienceDirect Topics. Retrieved 6 October 2021.
19. "The Effect of Aggregate Properties on Concrete". www. engr. psu. edu. Engr. psu. edu. 25 December 2012. Archived from the original on 25 December 2012. Retrieved 13 August 2022.
20. Veretennykov, Vitaliy I. ; Yugov, Anatoliy M. ; Dolmatov, Andriy O. ; Bulavytskyi, Maksym S. ; Kukharev, Dmytro I. ; Bulavytskyi, Artem S. (2008. "Concrete Inhomogeneity of Vertical Cast-in-Place Elements in Skeleton-Type Buildings". AEI 2008. pp. 1–10. doi:10. 1061/41002(328 17. ISBN 978-0784410028.
21. Gerry Bye; Paul Livesey; Leslie Struble (2011. "Admixtures and Special Cements". Portland Cement: Third edition. doi:10. 1680/pc. 36116. 185 (inactive 31 July 2022. ISBN 978-0727736116.
22. a b U. S. Federal Highway Administration (14 June 1999. "Admixtures". Archived from the original on 27 January 2007. Retrieved 25 January 2007.
23. Cement Admixture Association. "Admixture Types". Archived from the original on 3 September 2011. Retrieved 25 December 2010.
24. Hamakareem, Madeh Izat (14 November 2013. "Effect of Air Entrainment on Concrete Strength". The Constructor. Retrieved 13 November 2020.

25. Holland, Terence C. (2005. "Silica Fume User's Manual" (PDF. Silica Fume Association and United States Department of

Transportation Federal Highway Administration Technical Report FHWA-IF-05-016. Retrieved 31 October 2014.

26. Kosmatka, S. ; Kerkhoff, B. ; Panerese, W. (2002. Design and Control of Concrete Mixtures (14 ed. . Portland Cement Association, Skokie, Illinois.

27. Gamble, William. "Cement, Mortar, and Concrete". In Baumeister; Avallone; Baumeister (eds. . Mark's Handbook for Mechanical Engineers (Eighth ed. . McGraw Hill. Section 6, page 177.

28. Kosmatka, S. H. ; Panerese, W. C. (1988. Design and Control of Concrete Mixtures. Skokie, IL: Portland Cement Association. pp. 17, 42, 70, 184. ISBN 978-0893120870.

29. "Paving the way to greenhouse gas reductions". MIT News | Massachusetts Institute of Technology. 28 August 2011. Archived from the original on 31 October 2012. Retrieved 13 August 2022.

30. U. S. Federal Highway Administration (14 June 1999. "Fly Ash". Archived from the original on 21 June 2007. Retrieved 24 January 2007.

31. U. S. Federal Highway Administration. "Ground Granulated Blast-Furnace Slag". Archived from the original on 22 January 2007. Retrieved 24 January 2007.

32. U. S. Federal Highway Administration. "Silica Fume". Archived from the original on 22 January 2007. Retrieved 24 January 2007.

33. Mullapudi, Taraka Ravi Shankar; Gao, Di; Ayoub, Ashraf (September 2013. "Non-destructive evaluation of carbon nanofibre concrete". Magazine of Concrete Research. 65 (18: 1081–1091. doi:10.1680/mac.12.00187.

34. Tuan, Christopher; Yehia, Sherif (1 July 2004. "Evaluation of Electrically Conductive Concrete Containing Carbon Products for Deicing". ACI Materials Journal. 101 (4: 287–293.

35. "Cold Joints". www. concrete. org. uk. The Concrete Society. Archived from the original on 4 March 2016. Retrieved 30 December 2015.

36. "Grades of Concrete with Proportion (Mix Ratio ". 26 March 2018.

37. "Concrete International". concrete. org. 1 November 1989. Archived from the original on 28 September 2007. Retrieved 13 August 2022.
38. "ACI 304R-00: Guide for Measuring, Mixing, Transporting, and Placing Concrete (Reapproved 2009)".
39. Sarviel, Ed (1993. Construction Estimating Reference Data. Craftsman Book Company. ISBN 978-0-934041-84-3.
40. Cook, Marllon Daniel; Ghaeezadah, Ashkan; Ley, M. Tyler (1 February 2018. "Impacts of Coarse-Aggregate Gradation on the Workability of Slip-Formed Concrete". Journal of Materials in Civil Engineering. 30 (2 : 04017265. doi:10. 1061/(ASCE MT. 1943-5533. 0002126. ISSN 1943-5533.
41. "Aggregate in Concrete – the Concrete Network". Archived from the original on 2 February 2017. Retrieved 15 January 2017.
42. Ferrari, L. ; Kaufmann, J. ; Winnefeld, F. ; Plank, J. (October 2011. "Multi-method approach to study influence of superplasticizers on cement suspensions". Cement and Concrete Research. 41 (10 : 1058–1066. doi:10. 1016/j. cemconres. 2011. 06. 010.
43. "Curing Concrete" Peter C. Taylor CRC Press 2013. ISBN 978-0415779524. eBook ISBN 978-0203866139
44. "Concrete Testing". Archived from the original on 24 October 2008. Retrieved 10 November 2008.
45. Resulting strength distribution in vertical elements researched and presented at the article "Concrete inhomogeneity of vertical cast-in-place elements in skeleton-type buildings". Archived 3 April 2015 at the Wayback Machine
46. ""Admixtures for Cementitious Applications. "" (PDF. Archived from the original (PDF on 17 October 2016.
47. "Home" (PDF. Archived (PDF from the original on 8 December 2015. Retrieved 12 November 2015.
48. The American Heritage Dictionary of the English Language. Boston: Houghton Mifflin Harcourt. 2011. p. 106. ISBN 978-

0547041018.

49. "Asphalt concrete cores for embankment dams". International Water Power and Dam Construction. Archived from the original on 7 July 2012. Retrieved 3 April 2011.
50. Polaczyk, Pawel; Huang, Baoshan; Shu, Xiang; Gong, Hongren (September 2019. "Investigation into Locking Point of Asphalt Mixtures Utilizing Superpave and Marshall Compactors". *Journal of Materials in Civil Engineering*. 31 (9 : 04019188. doi:10. 1061/(ASCE MT. 1943-5533. 0002839. S2CID 197635732.
51. Reid, Carlton (2015. *Roads Were Not Built for Cars: How Cyclists Were the First to Push for Good Roads & Became the Pioneers of Motoring*. Island Press. p. 120. ISBN 978-1610916899.
52. Dalal, Sejal P. ; Dalal, Purvang (March 2021. "Experimental Investigation on Strength and Durability of Graphene Nanoengineered Concrete". *Construction and Building Materials*. 276: 122236. doi:10. 1016/j. conbuildmat. 2020. 122236. S2CID 233663658.
53. Dalal, Sejal P. ; Desai, Kandarp; Shah, Dhairya; Prajapati, Sanjay; Dalal, Purvang; Gandhi, Vimal; Shukla, Atindra; Vithlani, Ravi (January 2022. "Strength and feasibility aspects of concrete mixes induced with low-cost surfactant functionalized graphene powder". *Asian Journal of Civil Engineering*. 23 (1 : 39–52. doi:10. 1007/s42107-021-00407-7.
54. Falkow, Stanley; Rosenberg, Eugene; Schleifer, Karl-Heinz; Stackebrandt, Erko (13 July 2006. *The Prokaryotes: Vol. 2: Ecophysiology and Biochemistry*. Springer Science & Business Media. p. 1005. ISBN 978-0-387-25492-0.
55. Metwally, Gehad A. M. ; Mahdy, Mohamed; Abd El-Raheem, Ahmed El-Raheem H. (1 August 2020. "Performance of Bio Concrete by Using Bacillus Pasteurii Bacteria". *Civil Engineering Journal*. 6 (8 : 1443–1456. doi:10. 28991/cej-2020-03091559. ISSN 2476-3055. S2CID 221651057.
56. Raju, N. Krishna (2018. *Prestressed Concrete*, 6e. McGraw-Hill Education. p. 1131. ISBN 978-9387886254.

57. Tiwari, AK; Chowdhury, Subrato (2013. "An over view of the application of nanotechnology in construction materials". Proceedings of the International Symposium on Engineering under Uncertainty:

Safety Assessment and Management (ISEUSAM-2012. Cakrabarti, Subrata; Bhattacharya, Gautam. New Delhi: Springer India. p. 485. ISBN 978-8132207573. OCLC 831413888.

58. Saravanan, M. M. ; Sivaraja, M. (10 May 2016. "Study And Development Of The Properties Of Nano-Concrete". doi:10.5281/zenodo.51258.

59. Krishna Raju, N. (2018. Prestressed Concrete, 6e. ISBN 978-9387886254.

60. "Ground Water Recharging Through Pervious Concrete Pavement". ResearchGate. Retrieved 26 January 2021.

61. Lavars, Nick (10 June 2021. "Stanford's low-carbon cement swaps limestone for volcanic rock". New Atlas. Archived from the original on 10 June 2021. Retrieved 11 June 2021.

62. Celik, K. ; Jackson, M. D. ; Mancio, M. ; Meral, C. ; Emwas, A. - H. ; Mehta, P. K. ; Monteiro, P. J. M. (1 January 2014. "High-volume natural volcanic pozzolan and limestone powder as partial replacements for portland cement in self-compacting and sustainable concrete". Cement and Concrete Composites. 45: 136–147. doi:10.1016/j.cemconcomp.2013.09.003. hdl:11511/37244. ISSN 0958-9465. S2CID 138740924.

63. a b c Lemouagna, Patrick N. ; Wang, Kai-tuo; Tang, Qing; Nzeukou, A. N. ; Billong, N. ; Melo, U. Chinje; Cui, Xue-min (1 October 2018. "Review on the use of volcanic ashes for engineering applications". Resources, Conservation and Recycling. 137: 177–190. doi:10.1016/j.resconrec.2018.05.031. ISSN 0921-3449. S2CID 117442866.

64. Brown, R. J. ; Calder, E. S. (2005 , "Pyroclastics", in Selley, Richard C. ; Cocks, L. Robin M. ; Plimer, Ian R. (eds. , Encyclopedia of Geology, Oxford: Elsevier, pp. 386–397, doi:10.1016/b0-12-369396-9/00153-2, ISBN 978-0123693969, retrieved 6 October 2021

65. Izzo, Francesco; Arizzi, Anna; Cappelletti, Piergiulio; Cultrone, Giuseppe; De Bonis, Alberto; Germinario, Chiara; Graziano, Sossio Fabio; Grifa, Celestino; Guarino, Vincenza; Mercurio, Mariano;

Morra, Vincenzo (1 August 2016. "The art of building in the Roman period (89 BC – 79 AD : Mortars, plasters and mosaic floors from

- ancient Stabiae (Naples, Italy ". Construction and Building Materials. 117: 129–143. doi:10. 1016/j. conbuildmat. 2016. 04. 101. ISSN 0950-0618.
66. "MASUKO light concrete". Retrieved 13 November 2020.
67. "Relation Between Compressive and Tensile Strength of Concrete". Archived from the original on 6 January 2019. Retrieved 6 January 2019.
68. "Structural lightweight concrete" (PDF. Concrete Construction. The Aberdeen Group. March 1981. Archived from the original (PDF on 11 May 2013.
69. "Concrete and Embodied Energy – Can using concrete be carbon neutral". 22 February 2013. Archived from the original on 16 January 2017. Retrieved 15 January 2017.
70. Gajda, John (2001. "Energy Use of Single-Family Houses with Various Exterior Walls" (PDF. Archived (PDF from the original on 9 October 2022.
71. Green Building with Concrete. Taylor & Francis Group. 2015. ISBN 978-1498704113. [page needed]
72. "Features and Usage of Foam Concrete". Archived from the original on 29 November 2012.
73. "Unreinforced Masonry Buildings and Earthquakes: Developing Successful Risk Reduction Programs FEMA P-774". Archived from the original on 12 September 2011.
74. Si msir, C. C. ; Jain, A. ; Hart, G. C. ; Levy, M. P. (12–17 October 2008. Seismic Retrofit Design Of Historic Century-Old School Buildings In Istanbul, Turkey (PDF. 14th World Conference on Earthquake Engineering. Archived from the original (PDF on 11 January 2012.
75. Nawy, Edward G. (2008. Concrete Construction Engineering Handbook. CRC Press. ISBN 978-1420007657.

76. Lomborg, Bjørn (2001. The Skeptical Environmentalist: Measuring the Real State of the World. Cambridge University Press. p. 138. ISBN 978-0521804479.

77. "Minerals commodity summary – cement – 2007". US United States Geological Survey. 1 June 2007. Archived from the original on 13 December 2007. Retrieved 16 January 2008.
78. Murray, Lorraine. "Christ the Redeemer (last updated 13 January 2014)". Encyclopædia Britannica. Retrieved 5 November 2022.
79. a b "Reinforced concrete". www.designingbuildings.co.uk.
80. a b c d Claisse, Peter A. (2016, "Composites", Civil Engineering Materials, Elsevier, pp. 431–435, doi:10.1016/b978-0-08-100275-9.00038-3, ISBN 978-0081002759, retrieved 5 October 2021
81. a b Richardson, John (2003, Newman, John; Choo, Ban Seng (eds., "21 – Precast concrete structural elements", Advanced Concrete Technology, Oxford: Butterworth-Heinemann, pp. 3–46, ISBN 978-0750656863, retrieved 7 October 2021
82. a b "Mass Concret" (PDF. Archived from the original (PDF on 27 September 2011.
83. Sadowski, Łukasz; Mathia, Thomas (2016. "Multi-scale Metrology of Concrete Surface Morphology: Fundamentals and specificity". Construction and Building Materials. 113: 613–621. doi:10.1016/j.conbuildmat.2016.03.099.
84. "Winter is Coming! Precautions for Cold Weather Concreting". FPrimeC Solutions. 14 November 2016. Archived from the original on 13 January 2017. Retrieved 11 January 2017.
85. "306R-16 Guide to Cold Weather Concreting". Archived from the original on 15 September 2017.
86. a b Larn, Richard; Whistler, Rex (1993. "17 – Underwater concreting". Commercial Diving Manual (3rd ed. . Newton Abbott, UK: David and Charles. pp. 297–308. ISBN 0715301004.
87. "Mapping of Excess Fuel Consumption". Archived from the original on 2 January 2015.
88. "Leading the way to carbon neutrality" (PDF. HeidelbergCement. 24 September 2020. Archived (PDF from the original on 9 October

2022.

89. "Cement Clinker Calcination in Cement Production Process". AGICO Cement Plant Supplier. 4 April 2019.
90. "Carbon footprint" (PDF. Portland Cement Association. Archived (PDF from the original on 9 October 2022).
91. Proske, Tilo; Hainer, Stefan; Rezvani, Moien; Graubner, Carl-Alexander (September 2013. "Eco-friendly concretes with reduced water and cement contents – Mix design principles and laboratory tests". *Cement and Concrete Research*. 51: 38–46. doi:10. 1016/j. cemconres. 2013. 04. 011.
92. O’Hegarty, Richard; Kinnane, Oliver; Newell, John; West, Roger (November 2021. "High performance, low carbon concrete for building cladding applications". *Journal of Building Engineering*. 43: 102566. doi:10. 1016/j. jobe. 2021. 102566.
93. Lee, Jaehyun; Lee, Taegyu; Jeong, Jaewook; Jeong, Jaemin (January 2021. "Sustainability and performance assessment of binary blended low-carbon concrete using supplementary cementitious materials". *Journal of Cleaner Production*. 280: 124373. doi:10. 1016/j. jclepro. 2020. 124373. S2CID 224849505.
94. a b "The Economics | Construction & Demolition Recycling Association". *cdrecycling. org*. Retrieved 5 October 2021.
95. a b "How to Recycle | Construction & Demolition Recycling Association". *cdrecycling. org*. Retrieved 5 October 2021.
96. a b c d "Save Money and Reduce Environmental Impact by Recycling Concretes". *The Balance Small Business*. Retrieved 5 October 2021.
97. "Itaipu Web-site". 2 January 2012. Archived from the original on 9 February 2012. Retrieved 2 January 2012.
98. Sources, Other News (14 July 2009. "China's Three Gorges Dam, by the Numbers". *Probe International*. Archived from the original on 29 March 2017. Retrieved 13 August 2022.
99. "Concrete Pouring of Three Gorges Project Sets World Record". *People's Daily*. 4 January 2001. Archived from the original on 27 May

2010. Retrieved 24 August 2009.

100. "Concrete Pumping to 715 m Vertical – A New World Record Parbati Hydroelectric Project Inclined Pressure Shaft Himachal Pradesh – A case Study". The Masterbuilder. Archived from the original on 21 July 2011. Retrieved 21 October 2010.
101. "SCHWING Stetter Launches New Truck mounted Concrete Pump S-36". NBM&CW (New Building Materials and Construction World. October 2009. Archived from the original on 14 July 2011. Retrieved 21 October 2010.
102. Janyala, Sreenivas (7 January 2019). "Andhra Pradesh: Polavaram project enters Guinness Book of World Record for concrete pouring". The India Express. Retrieved 7 January 2020.
103. "Concrete Supplier for Landmark Tower". Archived from the original on 15 May 2013.
104. "The world record Concrete Supplier for Landmark Tower Unibeton Ready Mix". Archived from the original on 24 November 2012.
105. "Abu Dhabi – Landmark Tower has a record-breaking pour" (PDF. Al Habtoor Engineering. September–October 2007. p. 7. Archived from the original (PDF on 8 March 2011.
106. National Geographic Channel International / Caroline Anstey (2005 , Megastructures: Petronas Twin Towers
107. "Continuous cast: Exxcel Contract Management oversees record concrete pour". concreteproducts. com. 1 March 1998. Archived from the original on 26 May 2010. Retrieved 25 August 2009.
108. Exxcel Project Management – Design Build, General Contractors Archived 28 August 2009 at the Wayback Machine. Exxcel. com. Retrieved 19 February 2013.
109. "Contractors Prepare to Set Gates to Close New Orleans Storm Surge Barrier". www. construction. com. 12 May 2011. Archived from the original on 13 January 2013. Retrieved 13 August 2022.

110. Darvill, Timothy. The concise Oxford dictionary of archaeology. 6th ed. [i. e. 2nd ed. Oxford, U. K. : Oxford University Press, 2008. Padstone. ISBN 0199534047

111. "SAP R/3 SD Wiki". Retrieved 7 January 2019.

112. a b "It's official: Oracle closes on PeopleSoft acquisition". Computerworld. 10 January 2005. Retrieved 18 August 2021.
113. "Navision 3. 0". Archived from the original on 3 June 2021. Retrieved 7 January 2019.
114. a b c "History of CRM Software". comparecamp. com. Retrieved 8 February 2017.
115. Jha, Lakshman (2008. Customer Relationship Management: A Strategic Approach. ISBN 9788190721127. Retrieved 8 June 2017.
116. "Gartner Announces Customer Relationship Management Summit 2009". gartner. com. 5 August 2009. Archived from the original on 22 January 2014. Retrieved 8 February 2017.
117. "Industry Specific/Vertical Market CRM Solutions". smallbizcrm. com. Retrieved 8 February 2017.
118. The Forrester Wave: CRM Suites For Enterprise Organizations, Q4 2016, Forrester, 21 November 2016, retrieved 13 September 2017
119. Buttle, Francis; Maklan, Stan (11 February 2015. Customer Relationship Management: Concepts and Technologies. ISBN 9781317654766.
120. Wallace, Tracey (6 August 2019. "What is CRM? Definition, examples, benefits of customer relationship management". The Future of Customer Engagement and Experience. Retrieved 22 December 2022.
121. Feiz, Ghotbabadi, Khalifah, (2016-01 Customer Lifetime Value in Organisations
122. a b c d "Types of CRM and Examples | CRM Software". www. crmssoftware. com. Retrieved 22 November 2015.
123. a b "What is sales force automation (SFA ? - Definition from WhatIs. com". WhatIs. com. Retrieved 26 November 2015.
124. Buttle, Francis (2003. Customer relationship management. London: Routledge. ISBN 9781136412578.

125. a b c d "What is customer relationship management (CRM ? - Definition from WhatIs. com". SearchCRM. Retrieved 22 November 2015.
126. Josiah, Ahaiwe; Ikenna, Oluigbo (February 2015. "Role of Technology in Accounting and E-accounting". International Journal of Computer Science and Mobile Computing. 4 (2 : 208–215. Retrieved 27 October 2018.
127. "Definition - www. smartcrm. com". www. smartcrm. com. Retrieved 26 November 2015.
128. a b c Tavana, Ali Feizbakhsh. ; Fili, Saeed. ; Tohid, Alireza. ; Vaghari, Reza. & Kakouie, Saed. (November 2013. "Theoretical Models of Customer Relationship Management in Organizations". International Journal of Business and Behavioral Sciences. 3 (11 .
129. a b Greenberg, Paul (13 February 2017. "How customer data platforms can benefit your business". ZDNet.
130. a b Reinartz, Werner; Krafft, Manfred; Hoyer, Wayne D. (August 2004. "The Customer Relationship Management Process: Its Measurement and Impact on Performance". Journal of Marketing Research. 41 (3 : 293–305. doi:10. 1509/jmkr. 41. 3. 293. 35991. S2CID 167683988.
131. a b "What's Your Relational Intelligence?". strategy+business. Retrieved 23 November 2015.
132. a b c d Avery, Jill; Fournier, Susan; Wittenbraker, John (July 2014. "Unlock the Mysteries of Your Customer Relationships". Harvard Business Review. Retrieved 22 November 2015.
133. Zeng, Yun E; Wen, H. Joseph; Yen, David C (1 March 2003. "Customer relationship management (CRM in business-to-business (B2B e-commercenull". Information Management & Computer Security. 11 (1 : 39–44. doi:10. 1108/09685220310463722. ISSN 0968-5227.
134. Bolton, Ruth N. (1998 , "A Dynamic Model of the Duration of the Customer's Relationship with a Continuous Service Provider: The Role of Satisfaction," Marketing Science, 17 (1 , 45–65.

135. Fornell, Claes (1992 , "A National Customer Satisfaction Barometer: The Swedish Experience", *Journal of Marketing*, 56 (January , 6-22
136. a b c Mithas, Sunil. ; Krishnan, M. S. & Fornell, Claes (October 2005. "Why Do Customer Relationship Management Applications Affect Customer Satisfaction?". *Journal of Marketing*. 69 (4 : 201–209. doi:10.1509/jmkg.2005.69.4.201. S2CID 4650003.
137. Piccoli, Gabriele and L. Applegate (2003 , "Wyndham International: Fostering High-Touch with High-Tech", Case Study No. 9-803-092, Harvard Business School
138. Piccoli, Gabriele and L. Applegate (2003 , "Wyndham International: Fostering High-Touch with High-Tech", Case Study No. 9-803-092, Harvard Business School.
139. Business Strategy; 1999. 22. Leach, B. , Success of CRM systems hinges on the establishment of measurable benefits. *Pulp & Paper* 2003. 77(6 : p. 48
140. Richards, A. Keith, and E. Jones, Customer relationship management: Finding value drivers. *Industrial Marketing Management*, 2008. 37(2 : p. 120-130.
141. Mohammadhossein, N. , & Zakaria, N. H. (2012. Customer relationship management Benefits for Customers: Literature Review (2005-2012 .
142. Bolte, T. Still Struggling to Reduce Call Center Costs Without Losing Customers? 2007.
143. Silverman, L. L. , CUSTOMERS: RESPONSIVENESS, FOCUS, OR OBSESSION? The Australasian Powder Coater Painter-Fabricator, 2000. 29(2 .
144. Collica, R. S. , CRM Segmentation and Clustering Using SAS Enterprise Miner. 2007.
145. Adrian Payne, P. F. , A Strategic Framework for Customer Relationship Management. *Journal of Marketing*, 2005. 69.
146. Corie. The Top 5 Time-Saving Benefits of CRM. 2011.

147. Nambisan, S. , Designing Virtual Customer Environment for New Product Development: Toward a Theory. *Academy of Management Review*, 2002. 27(3 .
148. a b c "The story behind successful CRM - Bain & Company". [www. bain. com](http://www.bain.com). June 2002. Retrieved 23 November 2015.
149. DeVault, Gigi (28 March 2012. "Wondering How to Create the Ideal Consumer Profile? Learn the Basics". *The Balance Small Business*. Retrieved 15 August 2018.
150. "A Dozen Simple Ways to Improve Customer Relations - Enterprise Apps Today". [www. enterpriseappstoday. com](http://www.enterpriseappstoday.com). 27 July 2011. Retrieved 23 November 2015.
151. "A CRM success story". *Computerworld*. 7 November 2002. Retrieved 23 November 2015.
152. Avery, Jill. (2014. "Unlock the Mysteries of Your Customer Relationships", *Harvard Business Review*. August 2014. [https://hbr. org/2014/07/unlock-the-mysteries-of-your-customer-relationships](https://hbr.org/2014/07/unlock-the-mysteries-of-your-customer-relationships) Retrieved: 20 November 2015
153. "9 Ways to Improve Your Company's CRM System". *CIO*. Retrieved 23 November 2015.
154. SAP Insider (15 November 2007 Still Struggling to Reduce Call Center Costs Without Losing Customers? Archived 16 January 2012 at the Wayback Machine
155. Genesys. "What Is Contact Center CRM?".
156. "The contact center and CRM collision leads to a new dominant species". *Network World*. 2 March 2017.
157. "Gamification Comes to the Contact Center". *CRM Magazine*. Retrieved 26 November 2015.
158. "CRM in Customer Service". *CRM Magazine*. Archived from the original on 23 September 2015. Retrieved 22 November 2015.

159. "Contact center automation takes flight". SearchCRM. Retrieved 26 November 2015.

160. "7 Ways CRM Can Increase Your Sales [Infographic]". Salesforce Blog. Retrieved 23 November 2015.
161. Roberts-Phelps, Graham (2001. Customer Relationship Management: How to Turn a Good Business Into a Great One!. Thorogood. p. 140. ISBN 978-1854181190.
162. Prasongsukarn, Kriengsin (2006. "Customer relationship management from theory to practice: Implementation steps". Inspire Research Company.
163. Rebekah Henderson, B2B Insights (2013 How to build a B2B-friendly CRM Archived 28 December 2017 at the Wayback Machine
164. "B2B Marketing: What Makes It Special? | B2B International". B2B International. Retrieved 22 November 2015.
165. CRM Trends in Insurance Industry Archived 17 July 2021 at the Wayback Machine CRM Trends in Insurance Industry: April 2010
166. Greenberg, Paul (2009. CRM at the Speed of Light (4th ed. . McGraw Hill. p. 7.
167. "Closing More Deals With NoCRM. io's Improved Mobile App". CRM. org. 23 August 2018. Retrieved 29 June 2022.
168. "Salesforce Platform". Salesforce. com. Retrieved 29 June 2022.
169. "What Is Mobile CRM? Definition, Features & Best Apps". CRM. org. 19 December 2018. Retrieved 29 June 2022.
170. Put Cloud CRM to Work PC World: April 2010
171. Oracle Buys Cloud-based Customer Service Company RightNow For \$1. 5 Billion Techcrunch: 24 October 2011
172. "News Analysis: The Implications Of Oracle's Acquisition Of Taleo". Enterprise Irregulars. 9 February 2012. Retrieved 4 August 2021.
173. "Oracle to Buy Eloqua in \$810 Million Deal". The Wall Street Journal. 20 December 2012. ISSN 0099-9660. Retrieved 4 August 2021.

174. SAP Challenges Oracle With \$3.4 Billion SuccessFactors Purchase
Bloomberg Businessweek: 7 December 2011

175. "CRM Trends 2021: How the Pandemic Altered Customer Behavior Forever". www.informationweek.com. 18 February 2021. Retrieved 4 August 2021.
176. Forrester. "Three Key CRM Trends In 2021 That Will Allow You To Better Engage Your Customers". Forbes. Retrieved 4 August 2021.
177. Gagliardi, Natalie. "Oracle announces in-game ad measurement technology in new CX portfolio update". ZDNet. Retrieved 18 August 2021.
178. "Gartner's Top 54 CRM Case Studies, Sorted by Industry, for 2005". Retrieved 20 May 2005.
179. Destinationcrm.com CRM Magazine: May 2010
180. Nirpaz G. , Pizarro F. , Farm Don't Hunt: The Definitive Guide to Customer Success, March 2016, p. 101
181. "7 Top CRM Trends for 2017: A Look Ahead". CMS Wire.
182. Forbes (2015. "The Power of Enablement" (PDF. Forbes insights.
183. "CRM and ERP: What's The Difference?". CRM Switch. 8 August 2013. Retrieved 26 November 2015.
184. "Demystifying CRM Adoption Rates". CRM Magazine. 1 July 2006. Retrieved 22 November 2015.
185. It's all about the Customer, Stupid – The Importance of Customer-Centric Partners.
186. Jim Dickie, CSO Insights (2006 Demystifying CRM Adoption Rates.
187. Joachim, David. "CRM tools improve access, usability. " (cover story. B to B 87, no. 3 (11 March 2002 .
188. Law, Monica; Lau, Theresa; Wong, Y. H. (2003. "From customer relationship management to customer-managed relationship:

unraveling the paradox with a co-creative perspective". *Marketing Intelligence & Planning*. 21 (1) : 51–60. doi:10.1108/02634500310458153. hdl:10397/60525.

189. Nguyen, Bang; Simkin, Lyndon (2013. "The dark side of CRM: Advantaged and disadvantaged customers" (PDF. Journal of Consumer Marketing. 30: 17–30. doi:10. 1108/07363761311290812.
190. a b Editors of Encyclopedia Britannica. 3 June 2021. "International Organization for Standardization. " Encyclopedia Britannica. Retrieved 2022-04-26.
191. a b c d e "About ISO". ISO. Archived from the original on 4 October 2007.
192. a b "ISO – Members". ISO. Retrieved 18 November 2020.
193. "New 'net zero' standards could transform the climate – unless they're derailed". The Washington Post. Retrieved 18 March 2022.
194. "About us". iso. org. Retrieved 25 June 2018.
195. "Friendship among equals" (PDF. ISO. (page 20
196. "ISO name and logo". ISO. Archived from the original on 19 September 2012.
197. "A Brief History of ISO". University of Pittsburgh.
198. Friendship among equals – Recollections from ISO's first fifty years (PDF , International Organization for Standardization, 1997, pp. 15–18, ISBN 92-67-10260-5, archived (PDF from the original on 26 October 2012
199. Yates, JoAnne; Murphy, Craig N. (2006. "From setting national standards to coordinating international standards: The formation of the ISO" (PDF. Business and Economic History On-Line. 4. Retrieved 29 June 2021.
200. a b c "Structure and governance". International Organization for Standardization. Archived from the original on 19 September 2012.
201. "Council". International Organization for Standardization. Archived from the original on 3 November 2012.
202. "Technical committees". International Organization for Standardization. Archived from the original on 19 September 2012.

203. "Who develops ISO standards?". International Organization for Standardization. Archived from the original on 19 September 2012.

204. "Governance of technical work". International Organization for Standardization. Archived from the original on 19 September 2012.
205. "ISO/IEC JTC 1". International Organization for Standardization. Archived from the original on 15 December 2011.
206. "JTC 1 home page". ISO/IEC JTC 1. Retrieved 15 May 2021.
207. "ISO/IEC JTC 2 Joint Project Committee – Energy efficiency and renewable energy sources – Common terminology". International Organization for Standardization. Archived from the original on 6 October 2012.
208. "General information on ISO". ISO. Archived from the original on 5 October 2007.
209. a b c d e The ISO directives are published in two distinct parts:
210. "ISO/IEC Directives, Part 1: Procedures for the technical work" (PDF. ISO/IEC. 2012. Archived from the original (PDF on 13 June 2012. Retrieved 17 July 2012.
211. "ISO/IEC Directives, Part 2: Rules for the structure and drafting of International Standards" (PDF. ISO/IEC. 2011. Archived from the original (PDF on 16 October 2011. Retrieved 17 July 2012.
212. ISO. "ISO/IEC Directives and ISO supplement". Archived from the original on 16 May 2008.
213. ISO, ISO/IEC 17065:2012 Conformity assessment — Requirements for bodies certifying products, processes and services, published September 2012, revised 2018, accessed 3 October 2022
214. "What Does ISO Certification Cost?". Reciprocity. 11 November 2019.
215. a b "Freely Available Standards". ISO. 1 February 2011.
216. "Free ANSI Standards". Archived from the original on 3 April 2007.
217. a b c "About MPEG". chiariglione. org. Archived from the original on 21 February 2010.

218. a b c ISO. "International harmonized stage codes".
Archived from the original on 4 October 2007.

219. a b c d e f ISO. "Stages of the development of International Standards". Archived from the original on 12 August 2007.
220. a b c "The ISO27k FAQ – ISO/IEC acronyms and committees". IsecT Ltd. Archived from the original on 24 November 2005.
221. a b c ISO (2007. "ISO/IEC Directives Supplement – Procedures specific to ISO" (PDF. Archived (PDF from the original on 12 January 2012.
222. a b c ISO (2007. "List of abbreviations used throughout ISO Online". Archived from the original on 12 August 2007.
223. a b c "US Tag Committee Handbook" (DOC. March 2008.
224. a b c ISO/IEC JTC1 (2 November 2009 , Letter Ballot on the JTC 1 Standing Document on Technical Specifications and Technical Reports (PDF
225. ISO. "ISO deliverables". Archived from the original on 12 August 2007.
226. a b ISO (2022 , ISO/IEC Directives, Part 1 – Consolidated ISO Supplement – Procedure for the technical work – Procedures specific to ISO (PDF , retrieved 16 September 2022
227. ISO, IEC (5 November 2009. "ISO/IEC JTC 1/SC 29, SC 29/WG 11 Structure (ISO/IEC JTC 1/SC 29/WG 11 – Coding of Moving Pictures and Audio ". Archived from the original on 28 January 2001. Retrieved 7 November 2009.
228. ATG Access Ltd. , What is IWA 14?, published 11 March 2020, accessed 18 August 2020
229. "Shopping FAQs". ISO. Archived from the original on 5 October 2007.
230. Jelliffe, Rick (1 August 2007. "Where to get ISO Standards on the Internet free". oreillynet. com. Archived from the original on 24 November 2007. The lack of free online availability has effectively made ISO standard irrelevant to the (home/hacker section of the Open Source community.

231. "Report on WG1 activity for December 2007 Meeting of ISO/IEC JTC1/SC34/WG1 in Kyoto". iso/jtc1 sc34. Archived from the original on 12 August 2007.
232. "Ubuntu's Shuttleworth blames ISO for OOXML's win". ZDNet.com. 1 April 2008. Archived from the original on 4 April 2008
233. Allen, E, & Iano, J. (2008). Fundamentals of building construction: materials and methods. Hoboken, New Jersey: John Wiley & Sons Inc.
234. "GSA Public Buildings Service Assessing Green Building Performance" (PDF. Archived from the original (PDF on 2013-07-22.
235. "2020 Global Status Report for Buildings and Construction: Towards a Zero-emissions, Efficient and Resilient Buildings and Construction Sector - Executive Summary". 2020.
236. Nord, Natasa (2017), "Building Energy Efficiency in Cold Climates", Encyclopedia of Sustainable Technologies, Elsevier, pp. 149–157, doi:10.1016/b978-0-12-409548-9.10190-3, ISBN 978-0-12-804792-7, retrieved 2022-04-04
237. Global Alliance for Buildings and Construction; International Energy Agency; United Nations Environment Programme (2019). "2019 Global Status Report for Buildings and Construction Towards a zero-emissions, efficient, and resilient buildings and construction sector" (PDF. UN environment programme Document Repository. United Nations Environment Programme. Archived (PDF from the original on 2020-10-21. Retrieved 2020-10-20.
238. "Bioclimatic architecture, buildings that respect the environment". Iberdrola. Retrieved 2022-04-03.
239. IEA (2022), Buildings, IEA, Paris <https://www.iea.org/reports/buildings>
240. Goodhew S 2016 Sustainable Construction Processes A Resource Text. John Wiley & Son

241. Towards zero-emission efficient and resilient buildings
GLOBAL STATUS REPORT 2016 (PDF. Global Alliance for
Buildings and construction. 2016. p. 8. Retrieved 2022-04-01.

242. "World's second largest building, Shanghai Tower, achieves LEED Platinum | U. S. Green Building Council". www.usgbc.org. Retrieved 2021-12-10.
243. a b Mao, Xiaoping; Lu, Huimin; Li, Qiming (2009). "A Comparison Study of Mainstream Sustainable/Green Building Rating Tools in the World". 2009 International Conference on Management and Service Science. p. 1. doi:10.1109/ICMSS.2009.5303546. ISBN 978-1-4244-4638-4. S2CID 22176705.
244. Carson, Rachel. *Silent Spring*. N. p. : Houghton Mifflin, 1962. Print.
245. a b "Components of Green Building". *Green Building*. US EPA. Archived from the original on 2008-10-31. Retrieved 2008-11-03.
246. WBDG Sustainable Committee (March 8, 2018). "Sustainable: OVERVIEW". *Whole Building Design Guide*. Archived from the original on 2020-03-10.
247. Ilgin, Mehmet Ali; Gupta, Surendra M. (2010). "Environmentally Conscious Manufacturing and Product Recovery (ECMPRO : A Review of the State of the Art)". *Journal of Environmental Management*. 91 (3 : 563–591. doi:10.1016/j.jenvman.2009.09.037. PMID 19853369. Life cycle analysis (LCA is a method used to evaluate the environmental impact of a product through its life cycle encompassing extraction and processing of the raw materials, manufacturing, distribution, use, recycling, and final disposal^lverification needed^l
248. "ISO 14040:2006(en Environmental management — Life cycle assessment — Principles and framework". www.iso.org. Archived from the original on 2016-06-17. Retrieved 2021-02-24.
249. Khasreen, Mohamad; Banfill, Phillip F. ; Menzies, Gillian (2009). "Life-Cycle Assessment and the Environmental Impact of Buildings: A Review". *Sustainability*. 1 (3 : 674–701. doi:10.3390/su1030674.
250. Hegazy, T. (2002). Life-cycle stages of projects. *Computer-Based Construction Project Management*, 8.

251. Pushkar, S; Becker, R; Katz, A (2005. "A methodology for design of environmentally optimal buildings by variable grouping".

Building and Environment. 40 (8 : 1126. doi:10. 1016/j. buildenv. 2004. 09. 004.

252. "NREL: U. S. Life Cycle Inventory Database Home Page". www. nrel. gov. Archived from the original on 2009-03-18. Retrieved 2011-04-23.

253. "Naturally:wood Building Green with Wood Module 3 Energy Conservation" (PDF. Archived from the original (PDF on 2012-07-22.

254. Simpson, J. R. (November 2002. "Improved Estimates of tree-shade effects on residential energy use". Energy and Buildings. 34 (10 : 1067–1076. doi:10. 1016/S0378-7788(02 00028-2. Archived from the original on 2008-06-09. Retrieved 2008-04-30.

255. Gan, Vincent J. L. ; Lo, Irene M. C. ; Ma, Jun; Tse, K. T. ; Cheng, Jack C. P. ; Chan, C. M. (May 1, 2020. "Simulation optimisation towards energy efficient green buildings: Current status and future trends". Journal of Cleaner Production. 254: 120012. doi:10. 1016/j. jclepro. 2020. 120012. ISSN 0959-6526. S2CID 214281706.

256. Lockhart, Olga (February 2019. "4 Main Health & Green Building Benefits For Homeowners". PATHWAY. Retrieved 2020-09-18.

257. a b "Green Building Basics". California Integrated Waste Management Board. January 23, 2008. Archived from the original on 2009-12-10. Retrieved 2009-11-28.

258. Jonkers, Henk M (2007. "Self Healing Concrete: A Biological Approach". Self Healing Materials. Springer Series in Materials Science. Vol. 100. p. 195. doi:10. 1007/978-1-4020-6250-6_9. ISBN 978-1-4020-6249-0.

259. GUMBEL, PETER (December 4, 2008. "Building Materials: Cementing the Future". Archived from the original on 2008-12-05 – via www. time. com.

260. Palankar, Nitendra; Ravi Shankar, A. U. ; Mithun, B. M. (December 1, 2015. "Studies on eco-friendly concrete incorporating industrial waste as aggregates". International Journal of Sustainable

Built Environment. 4 (2 : 378–390. doi:10. 1016/j. ijsbe. 2015. 05. 002.
ISSN 2212-6090. S2CID 135944819.

261. Kuittinen, Matti; Zernicke, Caya; Slabik, Simon; Hafner, Annette (March 11, 2021. "How can carbon be stored in the built environment? A review of potential options". *Architectural Science Review*: 1–17. doi:10. 1080/00038628. 2021. 1896471. ISSN 0003-8628. S2CID 233617364.
262. "Five actions to improve the sustainability of steel". [www. ey. com](http://www.ey.com). Retrieved 2022-04-03.
263. Dennehy, Kevin (March 31, 2014. "Using more wood for construction can slash global reliance on fossil fuels". *Yale News*. Yale School of Forestry & Environmental Studies (F&ES , University of Washington's College of the Environment. Archived from the original on 2021-08-15. Retrieved 2021-08-15.
264. Carrington, Damian (July 7, 2022. "Plant-based meat by far the best climate investment, report finds". *The Guardian*. Retrieved 2022-07-10.
265. "Sustainable Facilities Tool: Relevant Mandates and Rating Systems". [sftool. gov](http://sftool.gov). Archived from the original on 2014-07-14. Retrieved 2014-07-03.
266. Lee, Young S; Guerin, Denise A (2010. "Indoor environmental quality differences between office types in LEED-certified buildings in the US". *Building and Environment*. 45 (5 : 1104. doi:10. 1016/j. buildenv. 2009. 10. 019.
267. KMC Controls (September 24, 2015. "What's Your IQ on IAQ and IEQ?". Archived from the original on 2021-04-12. Retrieved 2021-04-12.
268. "LEED - Eurofins Scientific". [www. eurofins. com](http://www.eurofins.com). Archived from the original on 2011-09-28. Retrieved 2011-08-23.
269. "HQE - Eurofins Scientific". [www. eurofins. com](http://www.eurofins.com). Archived from the original on 2017-07-03. Retrieved 2011-08-23.
270. "LEED - Eurofins Scientific". [www. eurofins. com](http://www.eurofins.com). Archived from the original on 2011-09-28. Retrieved 2011-08-23.

271. "BREEAM - Eurofins Scientific". www.eurofins.com.
Archived from the original on 2018-10-01. Retrieved 2011-08-23.

272. "IAQ Green Certification". Archived from the original on 2013-12-05. Retrieved 2013-12-05.
273. "LEED - U. S. Green Building Council". www.usgbc.org. Archived from the original on 2013-12-19.
274. (CalRecycle , California Department of Resources Recycling and Recovery. "Green Building HomeGreen Building: Section 01350". www.calrecycle.ca.gov. Archived from the original on 2013-12-12. Retrieved 2013-12-05.
275. "Best Practices Manual - CHPS. net". www.chps.net. Archived from the original on 2013-12-11. Retrieved 2013-12-05.
276. "About « BIFMA level Standard". levelcertified.org. Archived from the original on 2013-12-05. Retrieved 2013-12-05.
277. Faith, S. (April 4, 2018. "Health Risks Associated With Poor Indoor Air Quality". Home Air Care. Archived from the original on 2020-02-09. Retrieved 2019-09-18.
278. WBDG Sustainable Committee. (August 18, 2009. Sustainable. Retrieved October 28, 2009, from <http://www.wbdg.org/design/ieq.php> Archived 2009-12-23 at the Wayback Machine
279. "Asthma and Allergy Foundation of America Home Remodelling". Archived from the original on 2011-04-22.
280. "Naturally:wood Building Green with Wood Module 6 Health and Wellbeing" (PDF. Archived from the original (PDF on 2013-04-02.
281. "Indoor Air - Wiley Online Library". www.blackwellpublishing.com. Archived from the original on 2012-03-19. Retrieved 2011-05-09.
282. WBDG Sustainable Committee. (August 18, 2009. Sustainable. Retrieved November 28, 2009, from http://www.wbdg.org/design/optimize_om.php Archived 2010-02-17 at the Wayback Machine
283. "Building Operations and Maintenance Services - GSA Sustainable Facilities Tool". sftool.gov. Archived from the original on

2015-07-02. Retrieved 2015-07-01.

284. a b Kats, Greg; Alevantis, Leon; Berman, Adam; Mills, Evan; Perlman, Jeff (October 2003. The Cost and Financial Benefits of Green Buildings (PDF (Report. Archived from the original (PDF on 2008-10-27. Retrieved 2008-11-03.
285. "In Business magazine Green Builders Get Big Help from Deconstruction". Archived from the original on 2008-11-21.
286. "Naturally:wood Building Green with Wood Module 5 Durability and Adaptability" (PDF. Archived from the original (PDF on 2016-05-17.
287. Lange, Jorg; Grottker, Mathias; Otterpohl, Ralf. Water Science and Technology, Sustainable Water and Waste Management In Urban Areas, June 1998. [1] Retrieved:April 30, 2008.
288. Liu, Lei; Ledwich, Gerard; Miller, Wendy (November 22, 2016. Community centre improvement to reduce air conditioning peak demand. 7th International Conference on Energy and Environment of Residential Buildings, 20-24 November 2016, Brisbane, Australia. doi:10. 4225/50/58107ce163e0c.
289. Miller, Wendy; Liu, Lei Aaron; Amin, Zakaria; Gray, Matthew (2018. "Involving occupants in net-zero-energy solar housing retrofits: An Australian sub-tropical case study". Solar Energy. 159: 390. Bibcode:2018SoEn. . 159. . 390M. doi:10. 1016/j. solener. 2017. 10. 008.
290. Kats, Gregory. (September 24, 2010. Costs and Benefits of Green Buildings [Web Log Post]. Retrieved from <http://thinkprogress.org/climate/2010/09/24/205805/costs-and-benefits-of-green-buildings/#> Archived 2014-03-24 at the Wayback Machine
291. "Green Buildings - Challenges". California Sustainability Alliance. Archived from the original on 2010-12-19. Retrieved 2010-06-16.
292. Fedrizzi, Rick, "Intro – What LEED Measures. " United States Green Building Council, October 11, 2009.
293. Green building impacts worker productivity. (2012. CAD/CAM Update, 24(5 , Boué, George (July 8, 2010. "Linking Green Buildings,

Productivity and the Bottom Line". Greenbiz. Archived from the original on 2021-05-10. Retrieved 2021-01-09.

294. United States Green Building Council (July 27, 2012. "The Business Case for Green Building". Archived from the original on 2014-03-24. Retrieved 2014-03-09.

295. Langdon, Davis. The Cost of Green Revisited. Publication. 2007.

296. Fuerst, Franz; McAllister, Pat. Green Noise or Green Value? Measuring the Effects of Environmental Certification on Office Property Values. 2009. [2] Archived 2021-11-23 at the Wayback Machine Retrieved: November 5, 2010

297. Pivo, Gary; Fisher, Jeffrey D. Investment Returns from Responsible Property Investments: Energy Efficient, Transit-oriented and Urban Regeneration Office Properties in the US from 1998-2008. 2009. [3] Archived 2011-07-24 at the Wayback Machine Retrieved: November 5, 2010

298. Fuerst, Franz; McAllister, Pat. An Investigation of the Effect of Eco-Labeling on Office Occupancy Rates. 2009. [4] Archived 2011-02-21 at the Wayback Machine Retrieved: November 5, 2010

299. "Naturally:wood Building Green and the Benefits of Wood" (PDF. Archived from the original (PDF on 2012-05-29.

300. "ICC - International Code Council". www. iccsafe. org. Archived from the original on 2010-09-14. Retrieved 2021-11-23.

301. Graaf, Florijn. "SmartHood: the self-sufficient neighborhood of the future". Amsterdam smart city platform. Archived from the original on 2021-01-26. Retrieved 2021-02-04.

302. Salzano, Miabelle. "THE NETHERLANDS WILL SOON BE HOME TO A SELF-SUSTAINING ECO VILLAGE". Builder. ARCHITECT. Archived from the original on 2021-11-23. Retrieved 2021-02-04.

303. "Opinion | What Will Happen to Your Next Home if Builders Get Their Way?". The New York Times.

304. "ICC Letter" (PDF). energycommerce. house. gov. January 19, 2021. Retrieved 2021-01-25.

305. "ICC Response Letter" (PDF). International Code Council. February 2, 2021.

306. a b c d e Jefferis, Alan; Madsen, David A. ; Madsen, David P. (2011). Architectural Drafting and Design (6th ed.). Clifton Park, NY: Delmar. p. 156. ISBN 9781435481626.
307. a b Jones, A. Maurice Jr. (2021). Fire Protection Systems (3rd ed.). Burlington, Massachusetts: Jones & Bartlett Learning. p. 20. ISBN 9781284180138. Retrieved 8 November 2021.
308. LeClaire, Jennifer (April 24, 2005). "Builders win latest tiff over building codes". Sacramento Business Journal.
309. The Architect's Handbook of Professional Practice (PDF) (13th ed.). John Wiley & Sons. August 15, 2001. ISBN 9780471419693. Archived from the original (PDF) on November 9, 2012.
310. «2015 دك نوب الالملا نامتخاس دوجوم» . 2016-12-10 .
311. 293 F. 3d 791 (5th Cir. 2002 (
312. «Bulk. resource. org» هخسن رد 15-10-2008 . یلصا . یزاگاب زا هدش یزاگاب 2008-11-01 .
313. 'Charles II, 1666: An Act for rebuilding the City of London. ', Statutes of the Realm: volume 5: 1628–80 (1819) , pp. 603–12. URL: british-history. ac. uk, date accessed: 8 March 2007.
314. 'Book 1, Ch. 15: From the Fire to the death of Charles II', A New History of London: Including Westminster and Southwark (1773) , pp. 230–55. URL: <http://www.british-history.ac.uk/report.asp?compid=46732>. Date accessed: 7 March 2007.
315. Tricker, Ray (2011-03-03). Building Regulations in Brief. doi:10.4324/9780080959160. ISBN 9780080959160.
316. Petty, Stephen E. . Forensic engineering damage assessments for residential and commercial structures. Boca Raton, Fla. : CRC Press, Taylor & Francis Group, 2013. 447. Print.
317. "Roof, non-ventilated" def. 1. Evert, Klaus. Encyclopedic dictionary of landscape and urban planning multilingual reference in

Reference Book Of International Building Standards ——— **References**
English, Spanish, French and German. Berlin: Springer, 2010. 849.
Print. \

318. "Warm roof" def. 1. Gorse, Christopher A. , and David Johnston. A dictionary of construction, surveying, and civil engineering. Oxford: Oxford University Press, 2012. 482. Print.
319. Dekorne, Clayton (2014, February). Insulating Cathedral Ceilings: Practical solutions to prevent call backs and boost energy performance, *Journal of Light Construction* 41-47.
320. Kruger, Abe, and Carl Seville. *Green building: principles and practices in residential construction*. Clifton Park, N. Y. : Delmar Cengage Learning, 2013. 192. Print.
321. "ORNL roof and attic design proves efficient in summer and winter". Oak Ridge National Laboratory. September 10, 2012.
322. a b c Qafih, Y. (1982). Halichot Teman (Jewish Life in Sanà) (in Hebrew). Jerusalem: Ben-Zvi Institute. p. 199. ISBN 965-17-0137-4. OCLC 863513860.
323. a b Maimonides (1967). Mishnah, with Maimonides' Commentary (in Hebrew). Vol. 3. Translated by Yosef Qafih. Jerusalem: Mossad Harav Kook. p. 114. OCLC 233308346. , s. v. Kelim 20:5
324. Hai Gaon (1924), "Hai Gaon's Commentary on Seder Taharot", in Epstein, J. N. (ed.), *The Geonic Commentary on Seder Taharot - Attributed to Rabbi Hai Gaon* (in Hebrew), vol. 2, Berlin: Itzkowski, p. 85 (Ohalot 6:4), OCLC 13977130
325. . Archived from the original on 29 January 2010. Retrieved 27 September 2010.
326. "Intergraph CAESAR II - Pipe Stress Analysis". coade. com. Archived from the original on 2 May 2015. Retrieved 4 June 2015.
327. "PASS/START-PROF - Pipe Stress Analysis". passuite. com. Archived from the original on 8 January 2019. Retrieved 1 March 2019.
328. "SIGMA/ROHR2 - Pipe Stress Analysis Software". rohr2. com. Archived from the original on 12 April 2021. Retrieved 16 February 2022.

329. Temperature & Stress Analysis Archived 22 February 2014 at the Wayback Machine Piping Technology and Products, (retrieved February 2012)
330. "What is HDPE Pipe?". Acu-Tech Piping Systems. Retrieved 20 March 2019.
331. "BBC - A History of the World - Object : wooden water pipe". www. bbc. co. uk. Archived from the original on 7 May 2016. Retrieved 10 March 2016.
332. "Piping water through miles of Redwood". Popular Science: 74. December 1918. Archived from the original on 28 December 2017.
333. H. "ASTM A252 Pipe Pile". China Huayang Steel Pipe. Archived from the original on 16 October 2014.
334. "Korea Electro-technical Code". Ministry of Trade, Industry and Energy. Retrieved 17 September 2021.
335. Shigekura, Yuko. "FIRE RATING PROCEDURE IN JAPAN" (PDF) . International Association for Fire Safety Science.
336. Zalosh, Table 3. 3
337. Technical Note 1681 'LT Phan 'JL Gross 'TP McAllister ' 2010.
338. Railways Act 2005, ss. 2, 60/ Sch. 3 para. 3(1 (b (2 ; Railways Act 2005 (Commencement No. 5 Order 2006, SI 2006/266, art. 2(2 , Sch.
339. a b "HSL Annual Report and Accounts 2010/2011" (PDF. nationalarchives. gov. uk. Archived from the original (PDF on 10 May 2012. Retrieved 19 March 2018.
340. www. hsl. gov. uk Archived 13 January 2012 at the Wayback Machine A Century of Science
341. "Health and safety in mining". www. hse. gov. uk. Retrieved 19 March 2018.
342. "About OSHCR on the HSE website". Hse. gov. uk. Archived from the original on 14 August 2014. Retrieved 13 August 2014.

343. "Who's Who". www.ukwhoswho.com. Archived from the original on 17 November 2017. Retrieved 4 March 2016.
344. "Sarah Newton appointed as new Chair of HSE". gov.uk.
345. a b Knutt, Elaine (20 August 2018). "HSE's Richard Judge steps down as annual report shows drop in prosecutions". healthandsafetyatwork.com. Archived from the original on 11 August 2019. Retrieved 11 August 2019.
346. a b Green, Jason (27 June 2019). "New Chief Executive for HSE". HSE Media Centre. Archived from the original on 29 July 2019. Retrieved 29 July 2019.
347. "HSE response to Stockline 'too little, too late'". *Daily Herald*. 30 August 2009. Retrieved 19 December 2010.
348. "David Cameron declares war on the "nonsense" of the "over-the-top health and safety culture" The Tory Diary". Conservativehome.blogs.com. 1 December 2009. Retrieved 13 August 2014.
349. Political, Deputy (27 August 2010). "Health and safety laws are costing jobs". *The Daily Telegraph*. London. Archived from the original on 6 September 2010.
350. Dudman, Jane (30 June 2010). "Dispelling the myths around health and safety". *The Guardian*. London.
351. "Busting the health and safety myths". [Hse.gov.uk](http://hse.gov.uk). 30 June 2014. Retrieved 13 August 2014.
352. "HSE and local authorities hit back at 'health and Safety' myths". HSE. 3 July 2007. Archived from the original on 5 June 2011. Retrieved 19 December 2010.
353. Jordan-Meille ,L. ;Rubš;k ,G. H. ;Ehlert ,P. a. I. ;Genot ,V. ; Hofman ,G. ; Goulding, K. ;Recknagel ,J. ;Provolo ,G. ; Barraclough, P. (2012-12-01).
354. "An overview of fertilizer-P recommendations in Europe: soil testing, calibration and fertilizer recommendations". *Soil Use and Management*. 28 (4):419–435. doi/1111 .10;j. 1475 .2012 .2743-

355. On-the-spot, real-time and affordable soil testing technology is enhancing the agricultural value chain in Uganda.

356. On-the-spot, easy and affordable soil testing for Kenyan smallholder farmers.



ISO international standards for the construction industry help organizations apply a range of requirements and recommendations for building elements in the internal environment and the relationship with the surrounding environment so that the quality of construction is as high as possible.

This book is presented to the leaders, rulers and officials of the countries of the world, those who want the most beautiful and standard buildings in the world in their country. Leaders and rulers who, with their intelligent management, lead the best construction engineering in the country, and their main goal is always the happiness of their people and the progress of their country.

Dr. Abozar Shahpari

ISBN : 978-622-90096-5-9



9 786229 009659